

Model 159/160 Snack Vendor

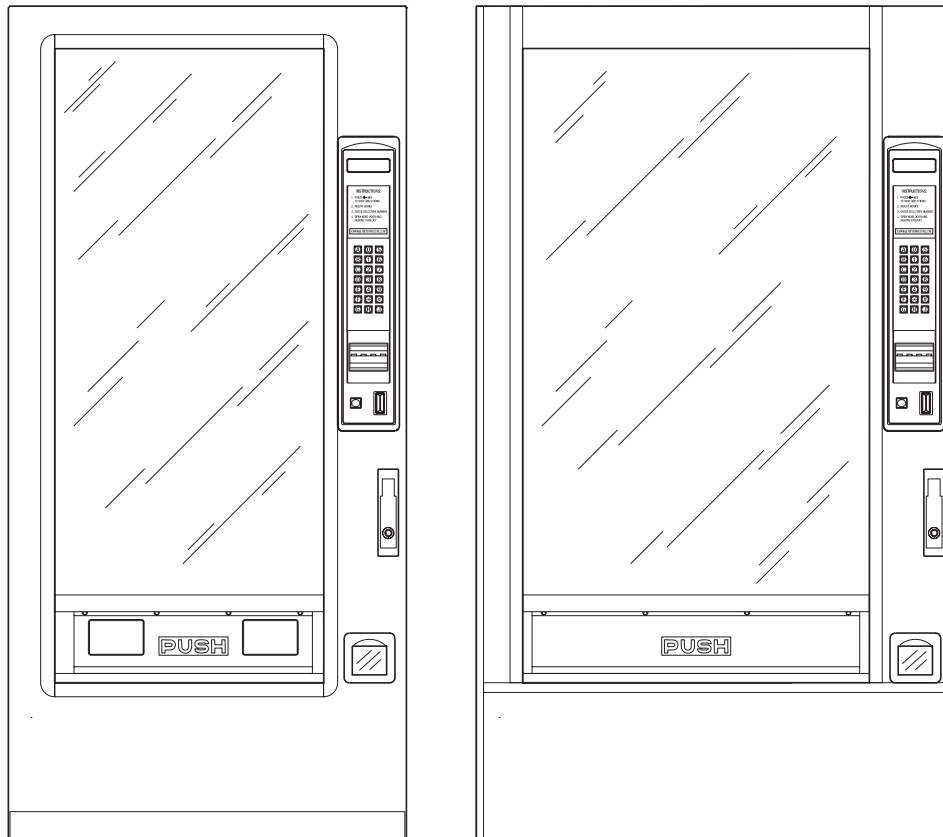

PARTS MANUAL

12955 Enterprise Way
Bridgeton, Missouri 63044-1200
(314) 298-3500

1590035

Copyright © 6-98

LIST OF FIGURES

FIGURE 1.	STANDARD DOOR ASSEMBLY	2
FIGURE 2.	GENERATION DOOR ASSEMBLY	4
FIGURE 3.	LIGHT ASSEMBLY - UPPER - DOOR	6
FIGURE 4.	DOOR LOCK GUARD ACCESSORY	8
FIGURE 5.	TRIM PANELS	10
FIGURE 6.	STANDARD TRIM	12
FIGURE 7.	GENERATION TRIM	14
FIGURE 8.	COIN RECEPTACLE ASSEMBLY	16
FIGURE 9.	DOOR LOCK AND HANDLE ASSEMBLY	18
FIGURE 10.	DELIVERY PAN ASSEMBLY	20
FIGURE 11.	GUM AND MINT UNIT.....	24
FIGURE 12.	LEG, LEVELER, AND LEG AND HINGE ASSEMBLIES	32
FIGURE 13.	COMMON CABINET	34
FIGURE 14.	POWER PANEL ASSEMBLY - 115 VOLT	42
FIGURE 15.	POWER PANEL ASSEMBLY - 120 VOLT EXEC.	44
FIGURE 16.	POWER PANEL ASSEMBLY - 230 VOLT	46
FIGURE 17.	MONETARY PANEL ASSEMBLY.....	48
FIGURE 18.	CARD READER AND BILL VALIDATOR COMBINATIONS	56
FIGURE 19.	CANDY TRAY ASSEMBLY.....	60
FIGURE 20.	SNACK TRAY ASSEMBLY.....	64
FIGURE 21.	GUM AND MINT TRAY ASSEMBLY	68
FIGURE 22.	BASE PLATE ASSEMBLY	72
FIGURE 23.	WIRING HARNESSSES	74

LIST OF TABLES

TABLE 1.	STANDARD DOOR ASSEMBLY	3
TABLE 2.	GENERATION DOOR ASSEMBLY	5
TABLE 3.	LIGHT ASSEMBLY - UPPER - DOOR	7
TABLE 4.	DOOR LOCK GUARD ACCESSORY	9
TABLE 5.	TRIM PANELS	11
TABLE 6.	STANDARD TRIM	13
TABLE 7.	GENERATION TRIM	15
TABLE 8.	COIN RECEPTACLE ASSEMBLY	17
TABLE 9.	DOOR LOCK AND HANDLE ASSEMBLY	19
TABLE 10.	DELIVERY PAN ASSEMBLY	21
TABLE 11.	GUM AND MINT UNIT	25
TABLE 12.	BAG ASSEMBLIES	30
TABLE 13.	LEG, LEVELER, AND LEG AND HINGE ASSEMBLIES	33
TABLE 14.	COMMON CABINET	35
TABLE 15.	POWER PANEL ASSEMBLY - 115 VOLT	43
TABLE 16.	POWER PANEL ASSEMBLY - 120 VOLT EXEC.	45
TABLE 17.	POWER PANEL ASSEMBLY - 230 VOLT	47
TABLE 18.	MONETARY PANEL ASSEMBLY	49
TABLE 19.	MONETARY INSTRUCTION INSERTS	55
TABLE 20.	CARD READER AND BILL VALIDATOR COMBINATIONS	57
TABLE 21.	BILL VALIDATOR OPTIONS	58
TABLE 22.	CARD READER OPTIONS	58
TABLE 23.	COIN MECHANISM OPTIONS	59
TABLE 24.	CANDY TRAY ASSEMBLY	61
TABLE 25.	SNACK TRAY ASSEMBLY	65
TABLE 26.	GUM AND MINT TRAY ASSEMBLY	69
TABLE 27.	SPIRAL OPTIONS	71
TABLE 28.	BASE PLATE ASSEMBLY	73

LIST OF TABLES

TABLE	PAGE
1. Standard Door Assembly	3
2. Generation Door Assembly	5
3. Light Assembly - Upper - Door	7
4. Door Lock Guard Accessory	9
5. Trim Panels	11
6. Standard Trim	13
7. Generation Trim	15
8. Coin Receptacle Assembly	17
9. Door Lock and Handle Assembly	19
10. Delivery Pan Assembly	21
11. Gum and Mint Unit (Part 1 of 2)	25
12. Gum and Mint Unit (Part 1 of 2)	27
13. Leg, Leveler, and Leg and Hinge Assemblies	31
14. Common Cabinet (Part 1 of 4)	33
15. Common Cabinet (Part 2 of 4)	35
16. Common Cabinet (Part 3 of 4)	37
17. Common Cabinet (Part 4 of 4)	39
18. Power Panel Assembly - 115 Volt	41
19. Power Panel Assembly - 120 Volt Exec.	43
20. Power Panel Assembly - 230 Volt	45
21. Monetary Panel Assembly (Part 1 of 4)	47
22. Monetary Panel Assembly (Part 2 of 4)	49
23. Monetary Panel Assembly (Part 3 of 4)	51
24. Monetary Panel Assembly (Part 4 of 4)	53
24 A. Monetary Instruction Inserts	53
25. Card Reader and Bill Validator Combinations	55
25 A. Bill Validator Options	56
25 B. Card Reader Options	56
25 C. Coin Mechanism Options	57
26. Candy Tray Assembly (Part 1 of 2)	59
27. Candy Tray Assembly (Part 2 of 2)	61
28. Snack Tray Assembly (Part 1 of 2)	63
29. Snack Tray Assembly (Part 2 of 2)	65
30. Gum and Mint Tray Assembly (Part 1 of 2)	67
31. Gum and Mint Tray Assembly (Part 2 of 2)	69
31 A. Spiral Options	69
32. Base Plate Assembly	71
33. Labels Used With 9985043	76

Snackvendor Models 159 - 160 Parts Manual

TABLE

PAGE

--	--

LIST OF FIGURES

FIGURE	PAGE
1. Standard Door Assembly	2
2. Generation Door Assembly	4
3. Light Assembly - Upper - Door	6
4. Door Lock Guard Accessory	8
5. Trim Panels.....	10
6. Standard Trim.....	12
7. Generation Trim.....	14
8. Coin Receptacle Assembly	16
9. Door Lock and Handle Assembly.....	18
10. Delivery Pan Assembly	20
11. Gum and Mint Unit (Part 1 of 2).....	24
12. Gum and Mint Unit (Part 1 of 2).....	26
13. Leg, Leveler, and Leg and Hinge Assemblies	30
14. Common Cabinet (Part 1 of 4).....	32
15. Common Cabinet (Part 2 of 4).....	34
16. Common Cabinet (Part 3 of 4).....	36
17. Common Cabinet (Part 4 of 4).....	38
18. Power Panel Assembly - 115 Volt	40
19. Power Panel Assembly - 120 Volt Exec.	42
20. Power Panel Assembly - 230 Volt	44
21. Monetary Panel Assembly (Part 1 of 4)	46
22. Monetary Panel Assembly (Part 2 of 4)	48
23. Monetary Panel Assembly (Part 3 of 4)	50
24. Monetary Panel Assembly (Part 4 of 4)	52
25. Card Reader and Bill Validator Combinations.....	54
26. Candy Tray Assembly (Part 1 of 2).....	58
27. Candy Tray Assembly (Part 2 of 2).....	60
28. Snack Tray Assembly (Part 1 of 2)	62
29. Snack Tray Assembly (Part 2 of 2)	64
30. Gum and Mint Tray Assembly (Part 1 of 2)	66
31. Gum and Mint Tray Assembly (Part 2 of 2)	68
32. Base Plate Assembly.....	70
33. Wiring Harnesses (Part 1).....	72

Snackvendor Models 159 - 160 Parts Manual

MODEL IDENTIFICATION

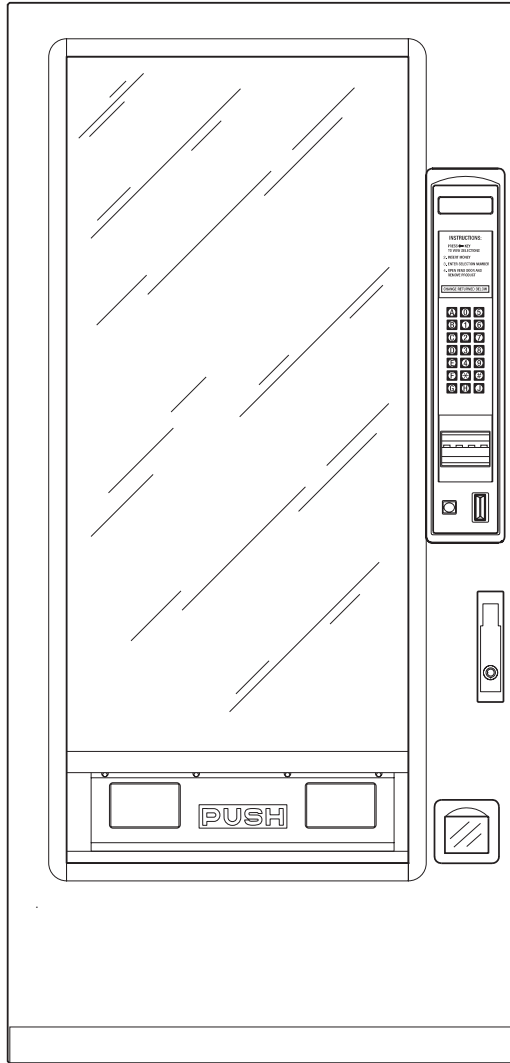

**160
(GENERATION STYLE)**

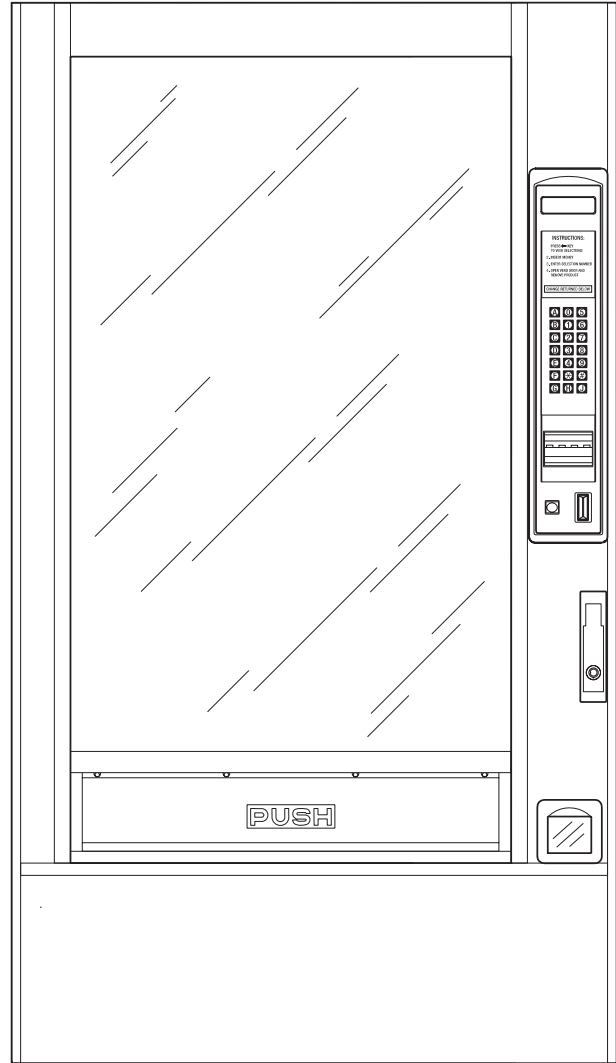

**159
(TRIM STYLE)**

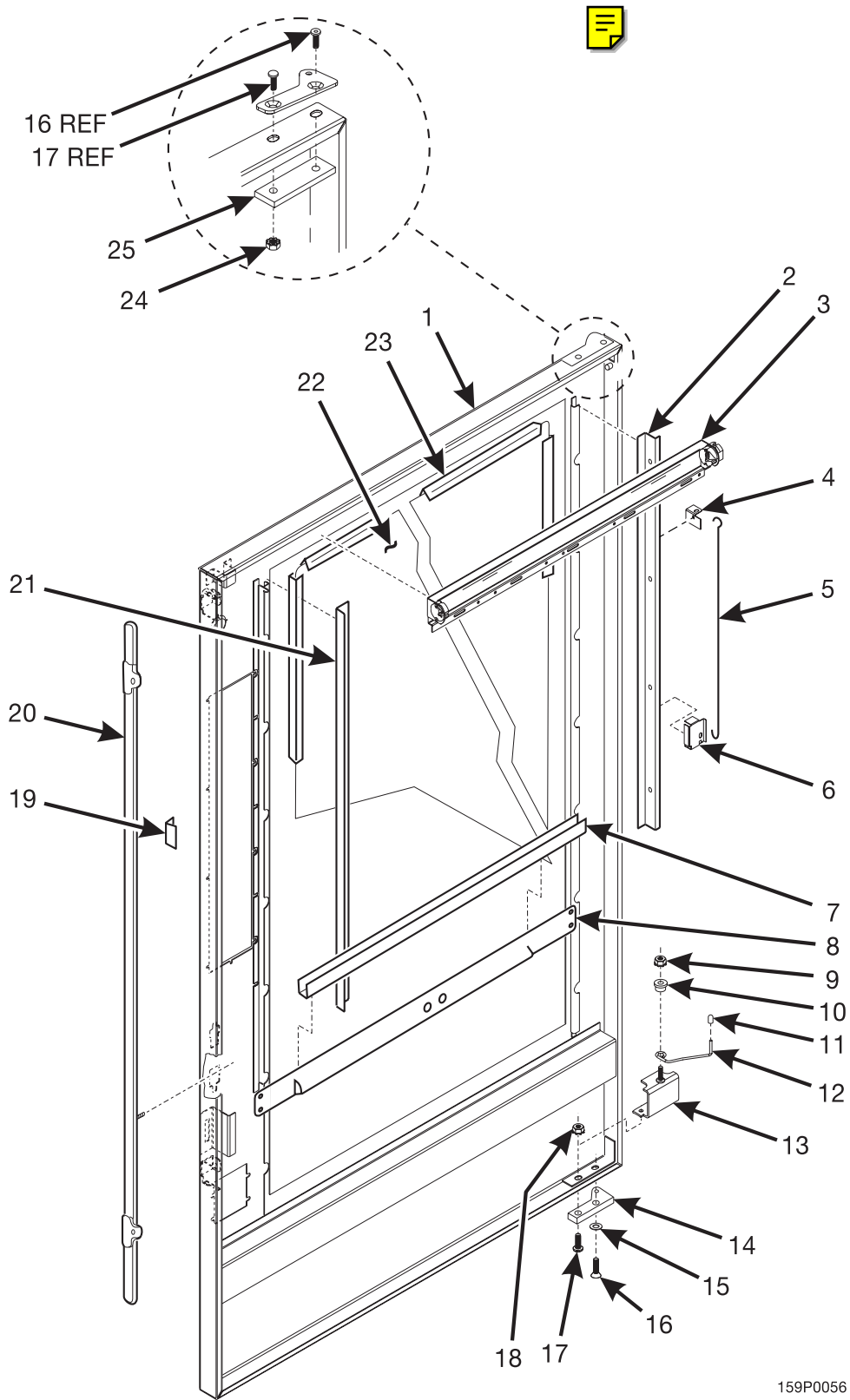

Figure 1. Standard Door Assembly

Snackvendor Models 159 - 160 Parts Manual

TABLE 29. STANDARD DOOR ASSEMBLY			
INDEX	PART NUMBER	DESCRIPTION	QTY.
1	1572225	WELD ASSEMBLY - STANDARD DOOR (159)	1
	1582069	WELD ASSEMBLY - STANDARD DOOR (160)	
2	1572020	RETAINER - GLASS (159)	1
	1582009	RETAINER - GLASS (160)	
-	1451097	SCREW (ATTACHING PART FOR INDEX # 2)	7
3	1572017	LIGHT ASSEMBLY - UPPER - DOOR (25W) (120 V MODEL 159) (SEE FIGURE 3 FOR DETAILS)	1
	1582004	LIGHT ASSEMBLY - UPPER - DOOR (20 W) (120 V MODEL 160, AND ALL 230 V MODELS)	
4	1572028	RETAINER - ROD SUPPORT - COMMON	1
5	1479140	ROD - SUPPORT - GUM & MINT	1
6	1572027	SUPPORT - PROP ROD - COMMON	1
7	1402120	CHANNEL - GLASS - LOWER (159)	1
	1462008	CHANNEL - GLASS - LOWER (160)	
8	1472220	STANDARD PANEL ASSEMBLY - GLASS - LOWER (159)	1
	1602026	STANDARD PANEL ASSEMBLY - GLASS - LOWER (160)	
-	1451097	SCREW (ATTACHING PART FOR INDEX # 8)	4
9	1211105	1/4-20 KEPS NUT EXT LW ZP	1
10	1142017	BUSHING - DOOR CHECK	1
11	1571037	CAP - VINYL - .281 ID X .50 LONG	1
12	1572009	ROD - DOOR CHECK	1
13	1572007	WELD ASSEMBLY - DOOR CHECK	1
14	6232031	HINGE ASSEMBLY - DOOR - LOWER	1
15	4242145	BEARING - THRUST - LOWER HINGE	1
16	6232036	SCREW - 5/16-18 X .75 FLAT HEAD SOCKET	1
17	6232208	WELD SCREW - #1/4-20 X 1" LG	1
18	1211105	1/4 - 20 KEPS NUT EXT LW ZP	1
19	1472250	GUIDE - LOCK BAR	1
20	1472178	LOCK BAR ASSEMBLY	1
21	1472048	PLATE - GLASS RETAINING	1
-	1451097	SCREW (ATTACHING PART FOR INDEX # 21)	7
22	1452059	GLASS - DISPLAY (159)	1
	1582075	GLASS - DISPLAY (160)	
	1452210	LEXAN DISPLAY GLASS (AVAILABLE ACCESSORY) (159)	OPT.
	1582089	LEXAN DISPLAY GLASS (AVAILABLE ACCESSORY) (160)	
23	1702010	CHANNEL - GLASS - UPPER 112.28 IN. LONG (159)	1
	1712002	CHANNEL - GLASS - UPPER - 106.16 IN. LONG (160)	
24	1211105	NUT	1
25	6232028	PLATE ASSEMBLY - HINGE MOUNTING	1

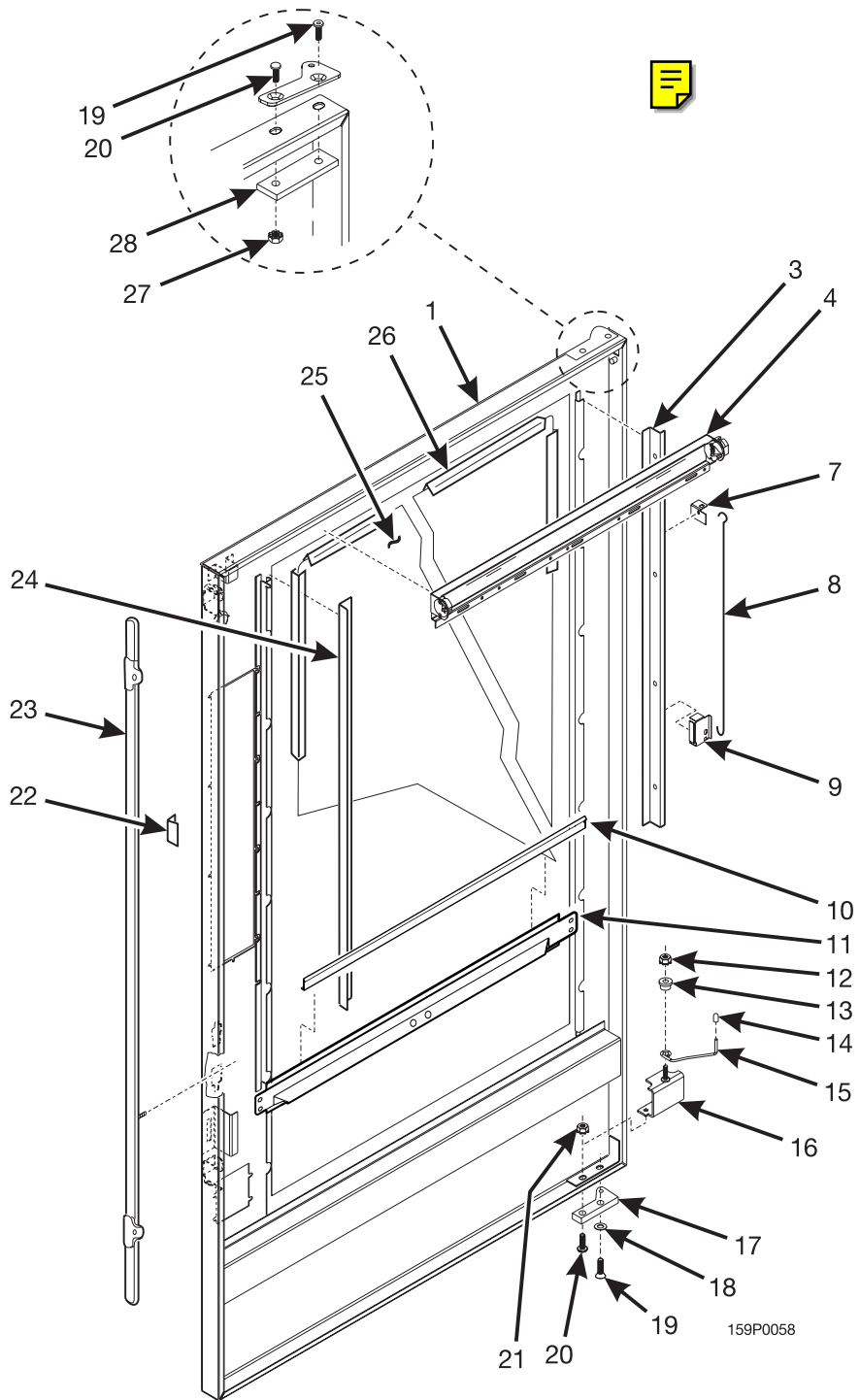

Figure 2. Generation Door Assembly

Snackvendor Models 159 - 160 Parts Manual

TABLE 30. GENERATION DOOR ASSEMBLY			
INDEX	PART NUMBER	DESCRIPTION	QTY.
1	1592064	WELD ASSEMBLY - GENERATION DOOR (159)	1
	1602050	WELD ASSEMBLY - GENERATION DOOR (160)	
2	1572020	RETAINER - GLASS	1
-	1451097	SCREW (ATTACHING PART FOR INDEX # 2)	7
3	1572017	LIGHT ASSEMBLY - UPPER - DOOR (25W) (120 V MODEL 159) (SEE FIGURE 3 FOR DETAILS)	1
	1582004	LIGHT ASSEMBLY - UPPER - DOOR (20 W) (120 V MODEL 160, AND ALL 230 V MODELS)	
4	1572028	RETAINER - ROD SUPPORT - COMMON	1
5	1479140	ROD - SUPPORT - GUM & MINT	1
6	1572027	SUPPORT - PROP ROD - COMMON	1
7	1402120	CHANNEL - GLASS - LOWER (159)	1
	1592073	CHANNEL - GLASS - LOWER (160)	
8	1592071	PANEL ASSEMBLY - GLASS - LOWER (159)	1
	1602053	PANEL ASSEMBLY - GLASS - LOWER (160)	
-	1451097	SCREW (ATTACHING PART FOR INDEX # 8)	4
9	1211105	1/4-20 KEPS NUT EXT LW ZP	1
10	1142017	BUSHING - DOOR CHECK	1
11	1571037	CAP - VINYL - .281 ID X .50 LONG	1
12	1572009	ROD - DOOR CHECK	1
13	1572007	WELD ASSEMBLY - DOOR CHECK	1
14	6232031	HINGE ASSEMBLY - DOOR - LOWER	1
15	4242145	BEARING - THRUST - LOWER HINGE	1
16	6232036	SCREW - 5/16-18 X .75 FLAT HEAD SOCKET	1
17	6232208	WELD SCREW - #1/4-20 X 1" LG	1
18	1211105	1/4 - 20 KEPS NUT EXT LW ZP	1
19	1592056	GUIDE - LOCK BAR	1
20	1472178	LOCK BAR ASSEMBLY	1
21	1472048	PLATE - GLASS RETAINING	1
-	1451097	SCREW (ATTACHING PART FOR INDEX # 21)	7
22	1452209	GLASS - DISPLAY (159)	1
	1582075	GLASS - DISPLAY (160)	
	1452210	LEXAN DISPLAY GLASS (AVAILABLE ACCESSORY) (159)	OPT.
	1582089	LEXAN DISPLAY GLASS (AVAILABLE ACCESSORY) (160)	
23	2222124	CHANNEL - GLASS - HOR. & VERT. (159) - 112.28 IN. LONG	-
		CHANNEL - GLASS - HOR. & VERT. (159) - 106.16 IN. LONG	
24	1211105	NUT	1
25	6232028	PLATE ASSEMBLY - HINGE MOUNTING	1
26	1211105	NUT	1
27	6232028	PLATE ASSEMBLY - HINGE MOUNTING	1

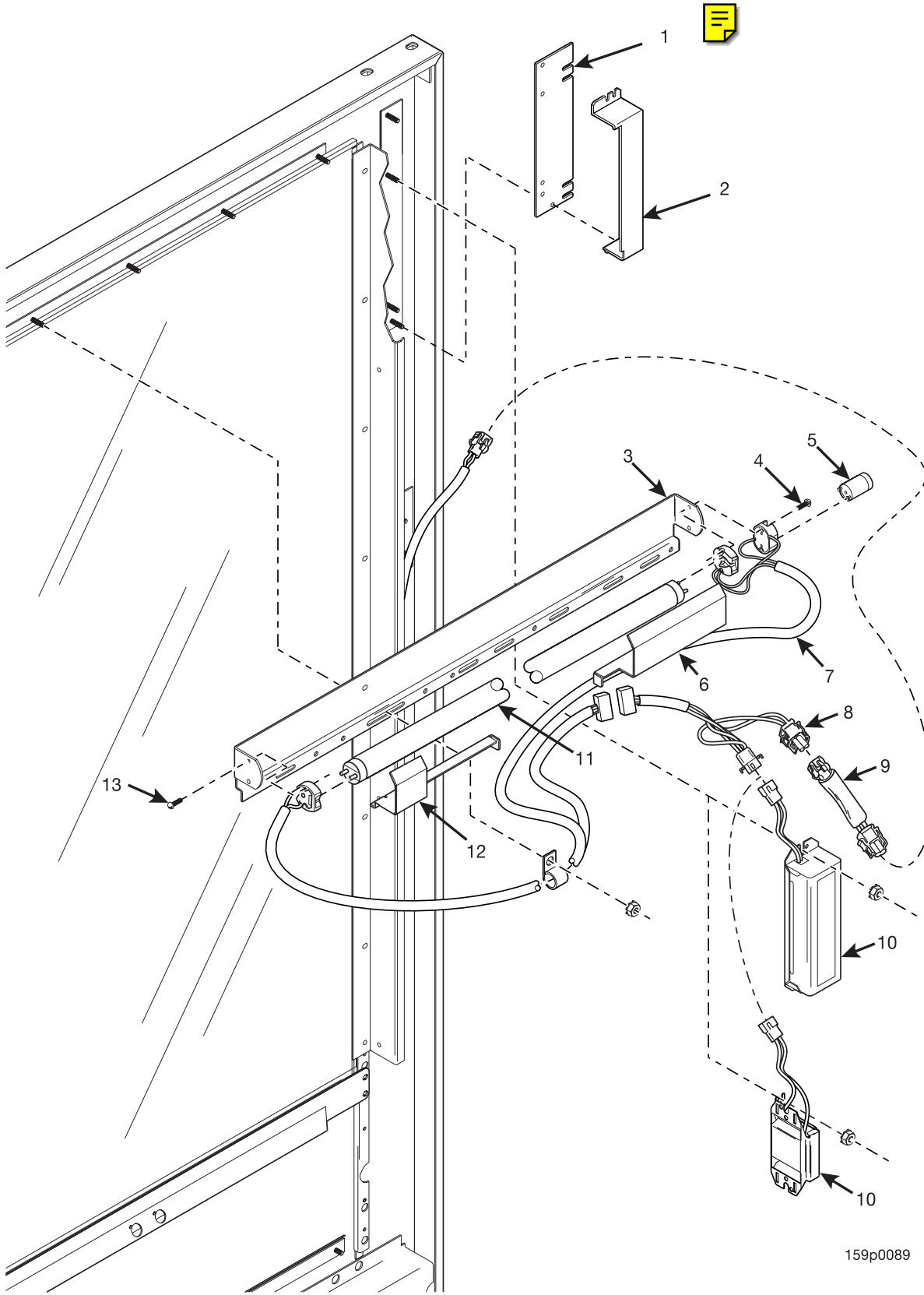

Figure 3. Light Assembly - Upper - Door

Snackvendor Models 159 - 160 Parts Manual

TABLE 31. LIGHT ASSEMBLY - UPPER - DOOR

INDEX	PART NUMBER	DESCRIPTION	QTY.
-	1572017	LIGHT ASSEMBLY - UPPER - DOOR (120 VOLT - MODEL 159) (INCLUDES INDEX NUMBERS 1 - 4)	-
	1582004	LIGHT ASSEMBLY - UPPER - DOOR (120 VOLT - MODEL 160 AND 230 VOLT MODELS 159 AND 160) (INCLUDES INDEX NUMBERS 1 - 4)	-
1	1572046	PLATE - BALLAST (230V MODELS)	1
2	1572047	COVER - BALLAST - EUROPE (230 V MODULES)	1
3	1572039	BRACKET - LIGHT - COMMON -25 WATT (159)	1
	1582025	BRACKET - LIGHT - COMMON - 20 WATT (160)	
4	3107171	SCREW - #4-36 X 5/8 RHS	2
5	2302218	STARTER - 25 WATT (115 VOLT MODEL 159)	1
	2222095	STARTER - 20 WATT (ALL 230 VOLT MODELS)	
6	1572045	COVER - LIGHT SOCKET - LEFT (230 V MODELS)	1
7	6339006	HARNESS - FLUORESCENT LIGHT (159)	1
	1582005	HARNESS - FLUORESCENT LIGHT (160)	
8	3156032	JUMPER - FILTER & FLUORESCENT LIGHT	1
9	1451124	SUPPRESSION NETWORK ASSEMBLY (115 VOLT)	1
	6332010	SUPPRESSION NETWORK ASSEMBLY (230 VOLT)	
10	6152188	BALLAST (115 VOLT MODEL 159)	1
	3151058	BALLAST (115 VOLT MODEL 160)	
	1572016	BALLAST (ALL 230 VOLT MODELS)	
11	1122138	FLUORESCENT LAMP - 20 WATT (ALL EXCEPT 115 VOLT MODEL 159)	1
	1172115	FLUORESCENT LAMP - 25 WATT (115 VOLT MODEL 159)	
12	1572044	COVER - LIGHT SOCKET - RIGHT (230 V MODELS)	1
13	1452076	SCREW - #4-36 X .437 RHS	2

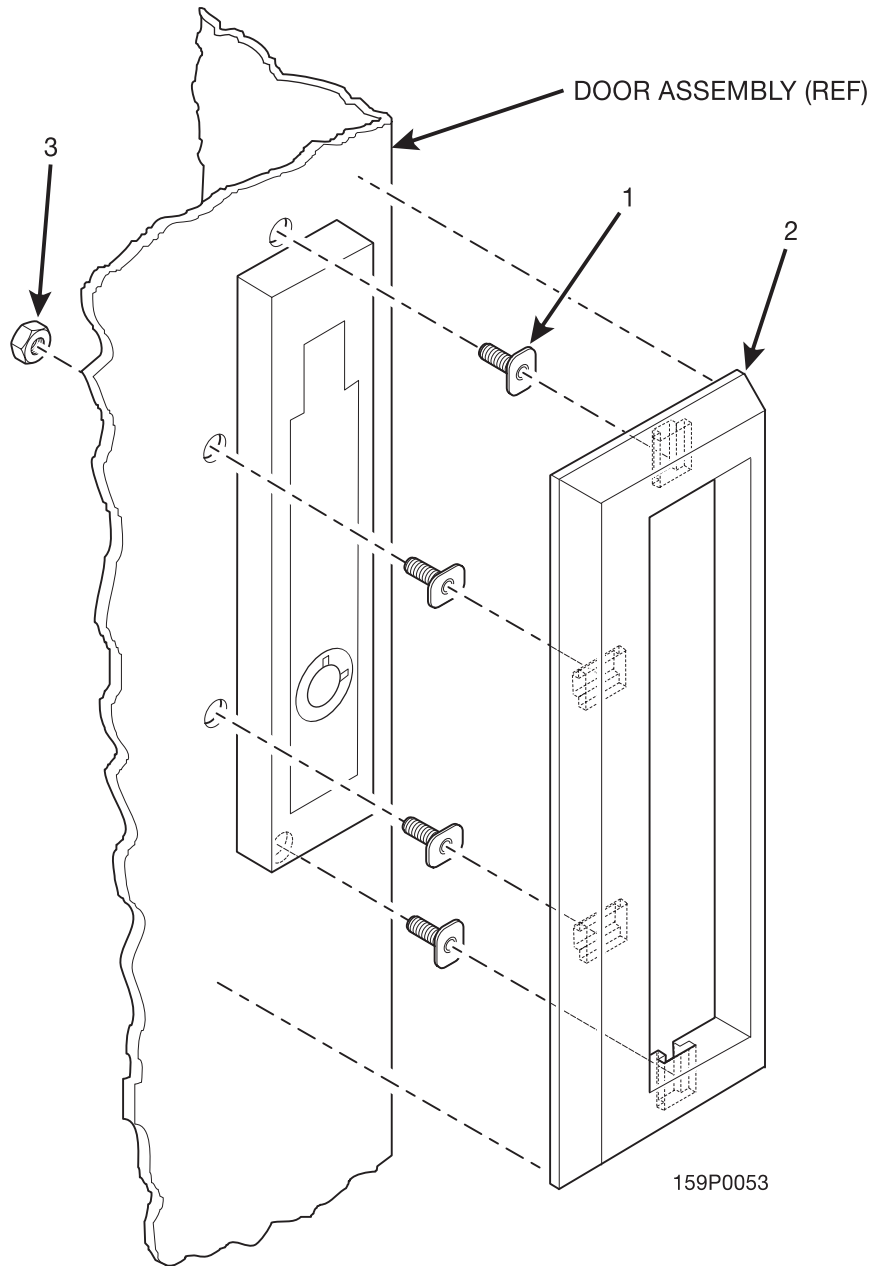

Figure 4. Door Lock Guard Accessory

Snackvendor Models 159 - 160 Parts Manual

TABLE 32. DOOR LOCK GUARD ACCESSORY

INDEX	PART NUMBER	DESCRIPTION	QTY.
-	1572188	DOOR LOCK GUARD KIT (INCLUDES ALL THE FOLLOWING ITEMS)	-
1	2222031	T-BOLT - TRIM	4
2	1572186	GUARD - LOCK	1
3	9900081	NUT - #8-32 - KEPS - ZINC PLATE	4
-	1572187	TEMPLATE AND INSTRUCTIONS (NOT SHOWN)	1

NOTE

This accessory requires drilling holes for T-bolts.

Snackvendor Models 159 - 160 Parts Manual

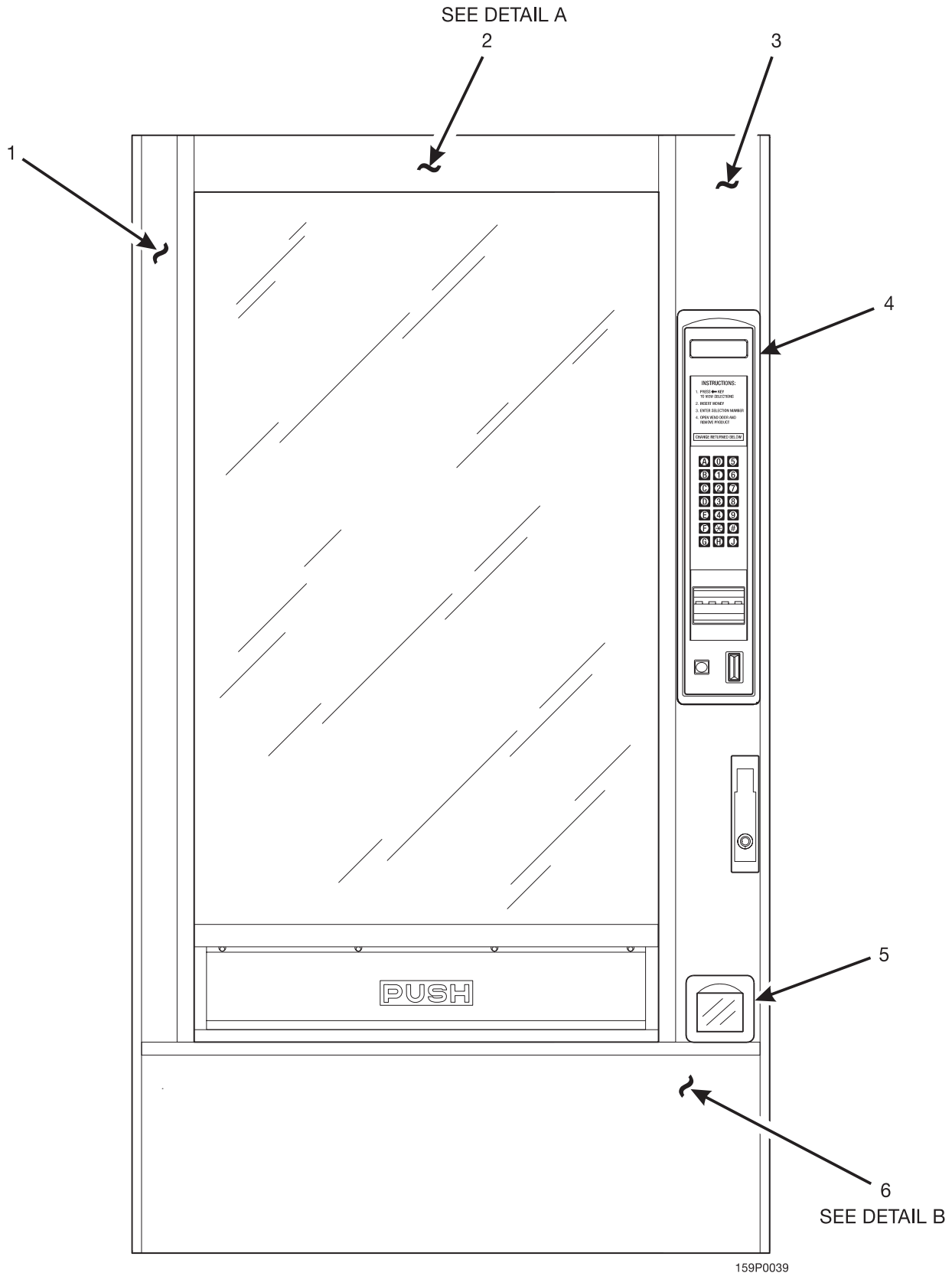
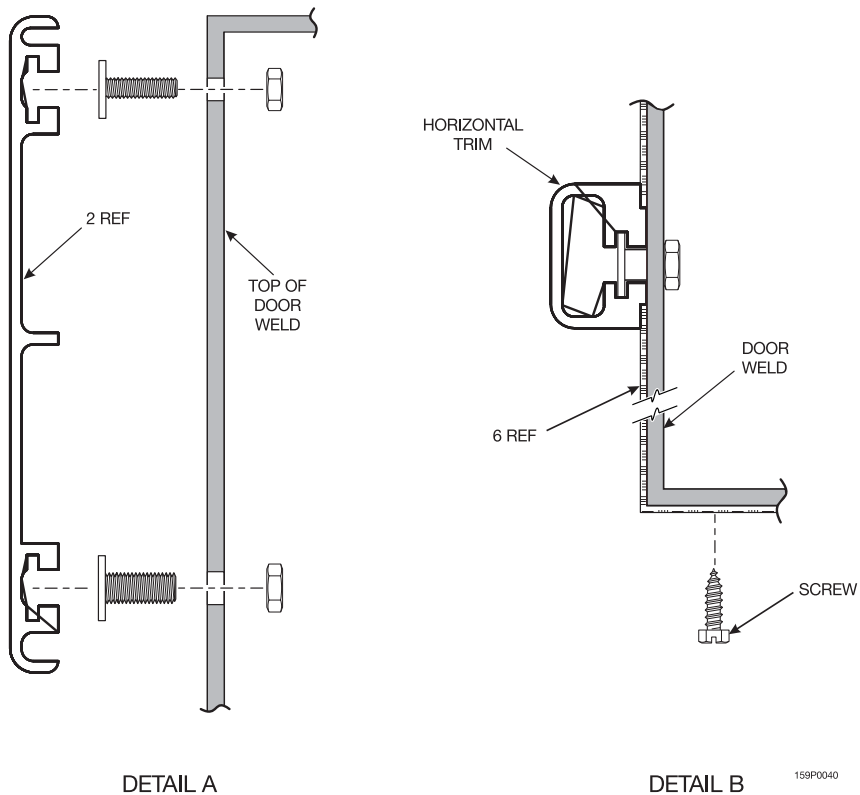

Figure 5. Trim Panels

Snackvendor Models 159 - 160 Parts Manual

TABLE 33. TRIM PANELS

INDEX	PART NUMBER	DESCRIPTION	QTY.
1	1592039	LEFT HAND TRIM PANEL - T. LIGHT GRAY	1
	1592045	LEFT HAND TRIM PANEL - T. BLACK	
	1592036	LEFT HAND TRIM PANEL - SPECIAL COLOR (160 ONLY)	
2	1592034	TOP TRIM PANEL - T. MEDIUM GRAY (159)	1
	1602029	TOP TRIM PANEL - T. MEDIUM GRAY (160)	
	1592043	TOP TRIM PANEL - T. BLACK (159)	
	1602040	TOP TRIM PANEL - T. BLACK (160)	
	1602028	TOP TRIM PANEL - SPECIAL COLOR (160 ONLY)	
3	1592038	RIGHT HAND TRIM PANEL - T. LIGHT GRAY	1
	1592044	RIGHT HAND TRIM PANEL - T. BLACK	
	1592035	RIGHT HAND TRIM PANEL - SPECIAL COLOR (160 ONLY)	
4	1575047	CASTING - MONETARY FRAME - BLACK	1
5	1572011	TRIM - COIN CUP - BLACK	1
6	1592040	BOTTOM TRIM PANEL - T. MEDIUM GRAY (159)	1
	1602036	BOTTOM TRIM PANEL - T. MEDIUM GRAY (160)	
	1592042	BOTTOM TRIM PANEL - T. BLACK (159)	
	1602041	BOTTOM TRIM PANEL - T. BLACK (160)	
	1602035	BOTTOM TRIM PANEL - SPECIAL COLOR (160 ONLY)	



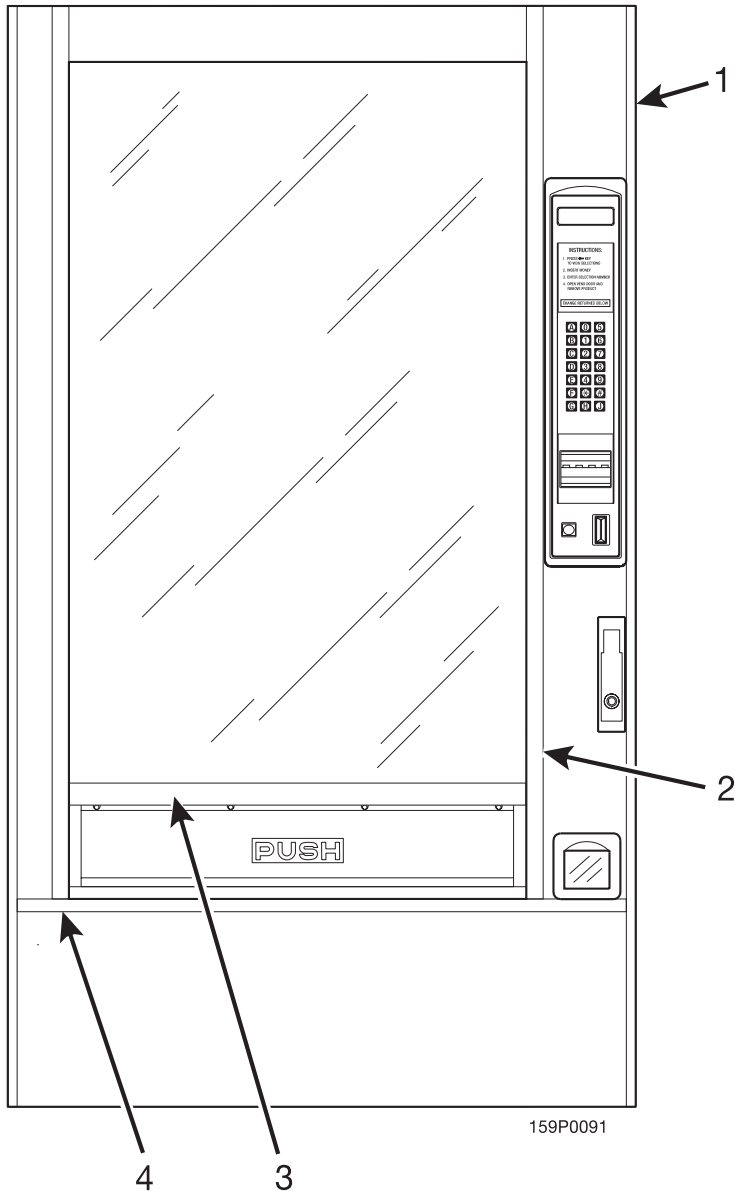
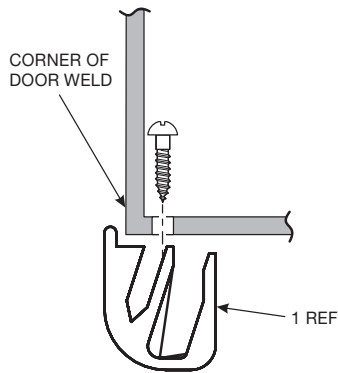

Figure 6. Standard Trim

Snackvendor Models 159 - 160 Parts Manual

TABLE 34. STANDARD TRIM

INDEX	PART NUMBER	DESCRIPTION	QTY.
1	1592032	TRIM - DOOR - SIDE - CLEAR	2
	1592069	TRIM - DOOR - SIDE - BLACK	
2	1592031	TRIM - DOOR - INSIDE - CLEAR	2
	1592068	TRIM - DOOR - INSIDE - BLACK	
3	1592041	TRIM PANEL - GLASS - LOWER - BLACK	1
	1602037	TRIM PANEL - GLASS - LOWER - BLACK	
4	1592030	TRIM - DOOR - HORIZONTAL - CLEAR (159)	1
	1602030	TRIM - DOOR - HORIZONTAL - CLEAR (160)	
	1592067	TRIM - DOOR - HORIZ - BLACK (159)	
	1602016	TRIM - DOOR - HORIZ - BLACK (160)	



DETAIL A

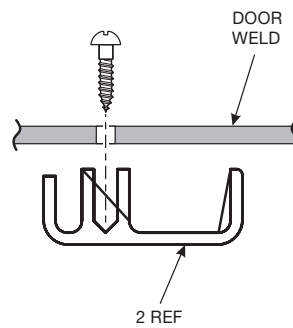

DETAIL B

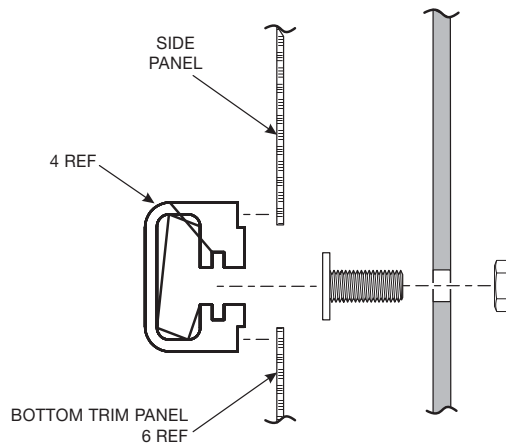

DETAIL C

159p0042

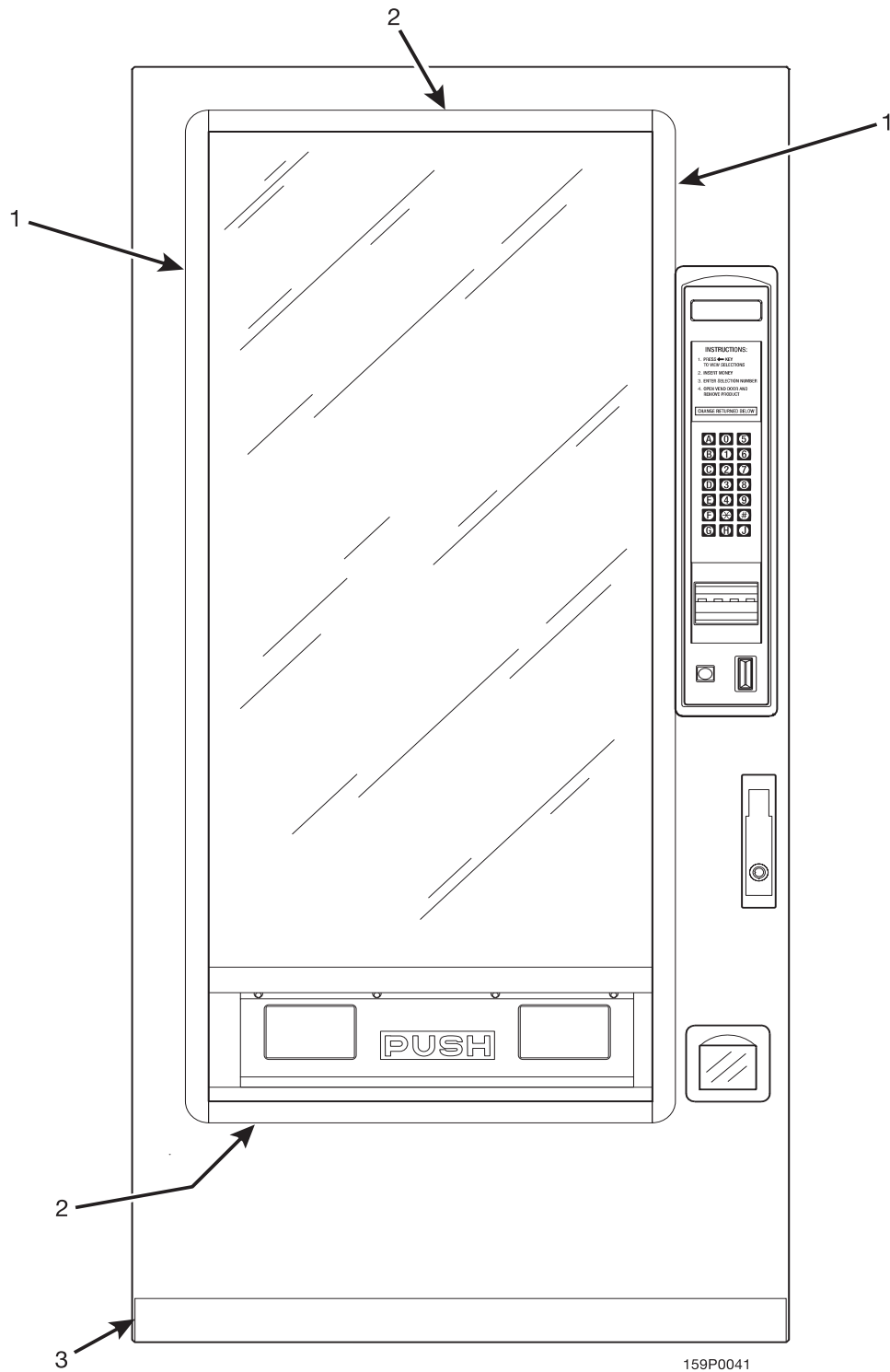

Figure 7. Generation Trim

Snackvender Models 159 - 160 Parts Manual

TABLE 35. GENERATION TRIM

INDEX	PART NUMBER	DESCRIPTION	QTY.
1	1592063	DECAL - TRIM - VERTICAL	2
2	1592060	DECAL - TRIM - HORIZONTAL - TOP (159)	2
	1602048	DECAL - TRIM - HORIZONTAL - TOP (160)	
3	1592061	DECAL - TRIM - HORIZONTAL - BOTTOM (159)	1
	1602049	DECAL - TRIM - HORIZONTAL - BOTTOM (160)	

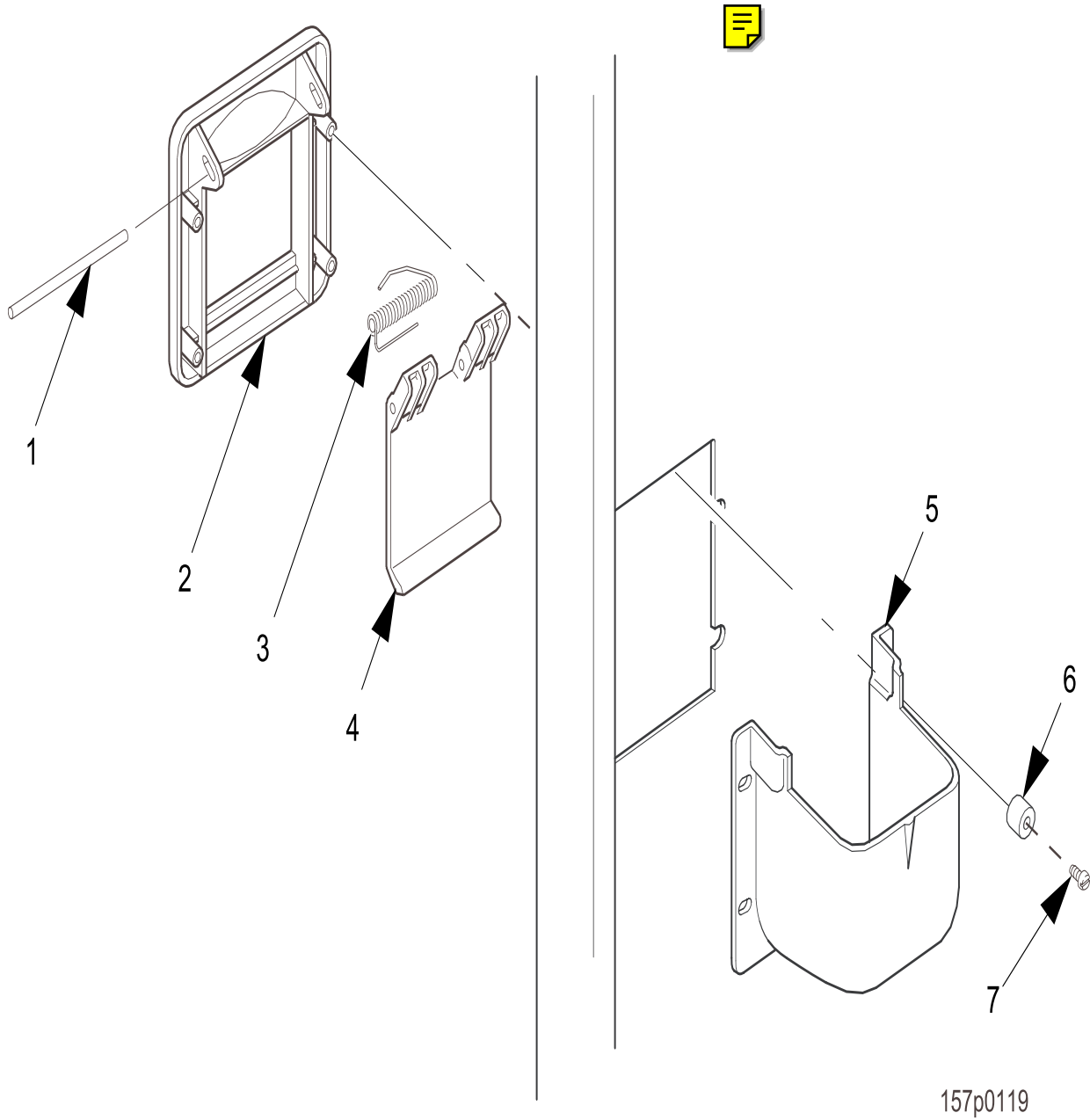

Figure 8. Coin Receptacle Assembly

Snackvendor Models 159 - 160 Parts Manual

TABLE 36. COIN RECEPTACLE ASSEMBLY

INDEX	PART NUMBER	DESCRIPTION	QTY.
1	1572011	TRIM - COIN CUP - BLACK	REF.
2	4245084	SHAFT - DOOR - COIN RETURN	1
3	4245083	SPRING - COIN RETURN DOOR	1
4	4245082	GATE - COIN RETURN	1
5	1572010	CUP COIN RETURN	1
6	2302053	SPACER - CUP	4
7	4042512	SCREW, #8-32 X 1/2 PHS S/T	4

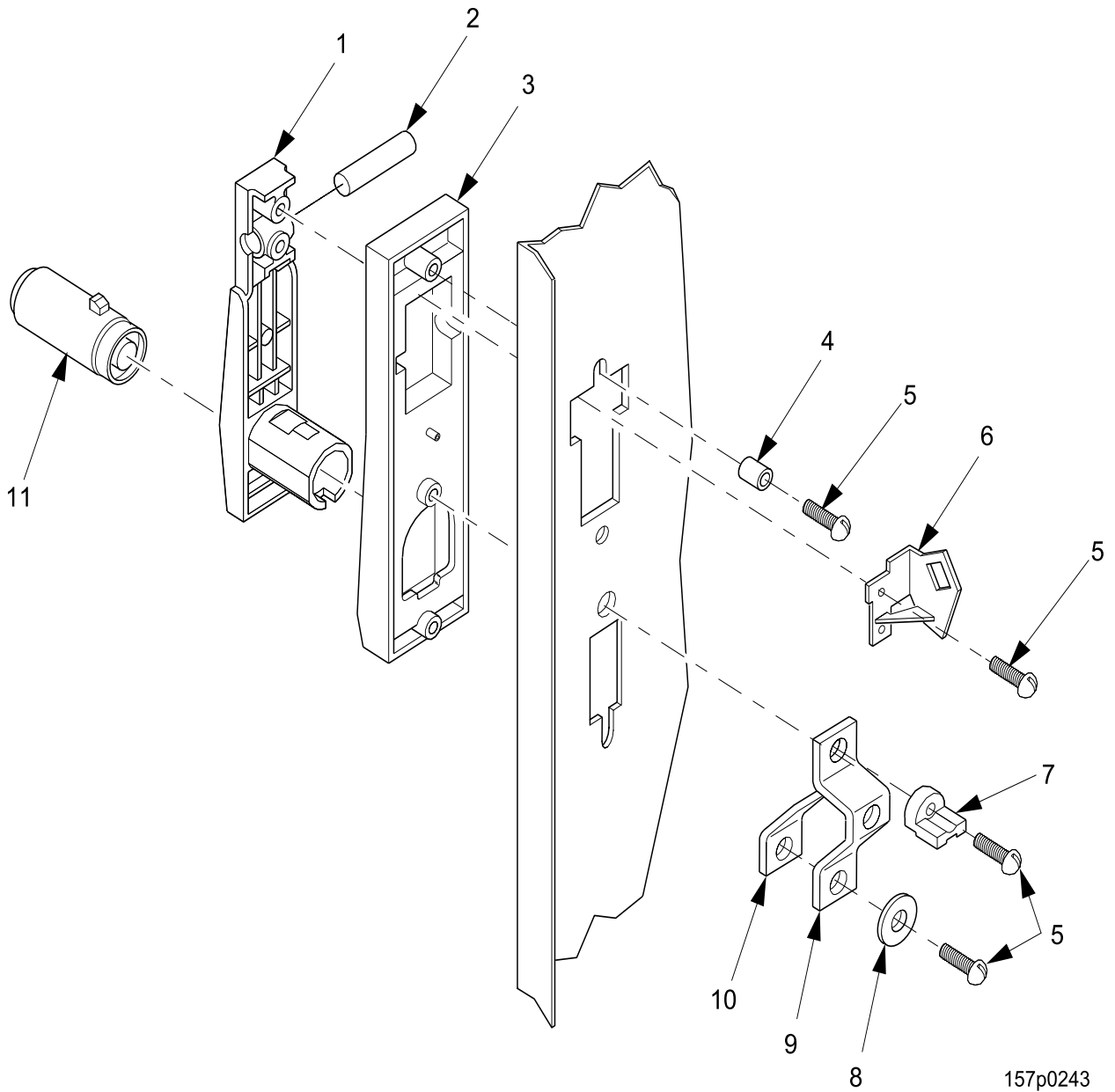
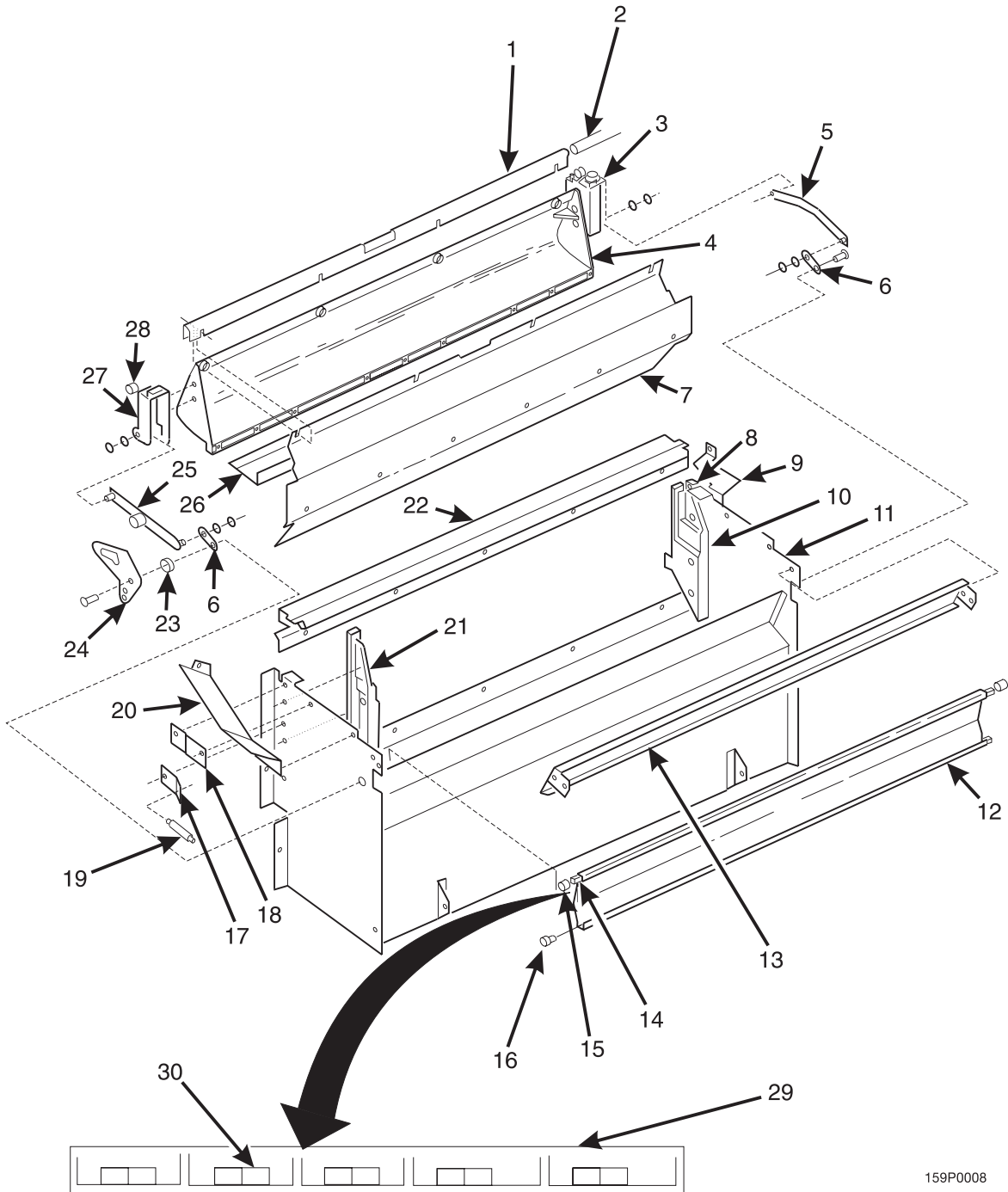

Figure 9. Door Lock and Handle Assembly

Snackvendor Models 159 - 160 Parts Manual

TABLE 37. DOOR LOCK AND HANDLE ASSEMBLY

INDEX	PART NUMBER	DESCRIPTION	QTY.
1	1172190	LEVER - LOCK	1
2	1302291	PIVOT - LEVER LOCK	1
3	1172191	BASE - LEVER LOCK	1
4	2272052	ACTUATOR ASSEMBLY - LOCK BAR	1
5	1302289	CUP SPACER	1
6	1217161	SCREW, #10-32 X 1/2 RHS W/LW	5
7	1302326	SHIELD - LATCH	1
8	9900121	WASHER - STEEL - 7/16 X .203 X .032	1
9	1302324	CATCH - DOOR LATCH	1
10	1302290	LATCH - LOCK LOWER	1
11	9992400	CYLINDER - LOCK	1
	3112163	VAN LOCK	OPT.
-	3112164	KEY (NOT SHOWN) VAN LOCK APPLICATION (NOT SHOWN)	1 OPT.



159P0008

Figure 10. Delivery Pan Assembly

Snackvendor Models 159 - 160 Parts Manual

TABLE 38. DELIVERY PAN ASSEMBLY			
INDEX	PART NUMBER	DESCRIPTION	QTY.
-	1572043	DELIVERY PAN ASSEMBLY (159)	1
	1602039	DELIVERY PAN ASSEMBLY (160)	
1	1412028	CHANNEL - DOOR (159)	1
	1462035	CHANNEL - DOOR (160)	
-	1170206	SCREW #8-32 X 3/8 THS BLACK	4
-	1402052	NUT CARRIAGE #8-32	4
2	1472228	SHAFT - DOOR PIVOT (159)	1
	1482002	SHAFT - DOOR PIVOT (160)	1
3	1472272	ACTUATOR - DELIVERY DOOR - L.H. (159)	1
	1482252	ACTUATOR - DELIVERY DOOR - L.H. (160)	
-	1170206	SCREW - #8-32 X 3/8 THS BLACK	2
-	1412046	8-32 NUT MF 23TW832 BLOX	2
4	1472137	DOOR - DELIVERY - GRAY (159)	1
	1582024	DOOR - DELIVERY - GRAY (160)	
5	4402017	ACTUATOR ASSEMBLY	1
-	9900146	RETAINING RING E TYPE .312	2
-	9900171	WASHER BRASS 9/16 X.315 X.040	2
6	1472145	ACTUATOR - REAR PIVOT	2
-	1170206	SCREW - #8-32X3/8 THS BLACK	1
-	9900202	SCREW - #8-32 X 5/8 PHS W/LKW	1
-	2204093	WASHER - SCAVENGER BAR	1
7	1472108	LINER - DOOR - PILFERAGE (159)	1
	1482163	LINER - DOOR - PILFERAGE (160)	
-	7207019	SCREW - #8-18 X 3/8 PHS TAPPING	6
8	1472069	BRACKET - DOOR PIVOT - L.H.	1
-	1170206	SCREW - #8-32 X 3/8 THS BLACK	1
-	9900081	NUT - #8-32 KEPS ZINC PLATE	1
9	1572169	DEFLECTOR - COMMON - LARGE SNACK (159)	1
	1602014	DEFLECTOR - L.H. - SMALL - GLASCO SNACK (160/468/490)	
	4852044	DEFLECTOR - L.H. (493)	
-	1170206	SCREW - #8-32 X 3/8 THS BLACK	2
-	9900081	NUT - #8-32 KEPS ZINC PLATE	2
10	1412023	FILLER - LEFT (159)	1
	1602034	FILLER - LEFT (160)	
-	1306140	8-32X3/8 CARR BOLT BLK/OX	3
-	9900081	NUT #8-32 KEPS ZINC PLATE	3
11	1472288	WELD ASSY-DELIVERY PAN (159)	1
	1602038	WELD ASSY-DELIVERY PAN (160)	
12	1472138	ASSEMBLY - REAR DELIVERY DOOR (159)	1
	1482171	ASSEMBLY - REAR DELIVERY DOOR (160)	

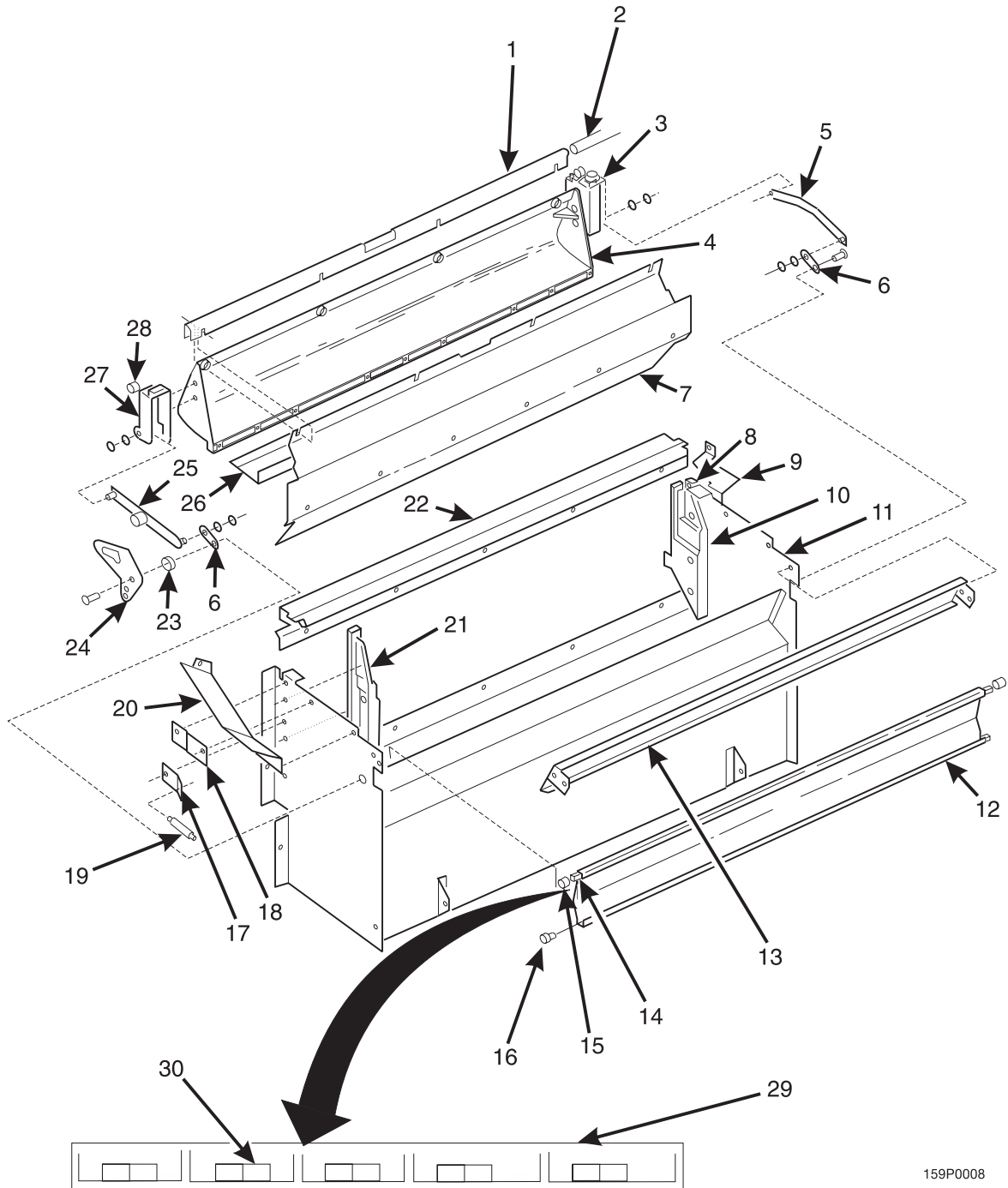

159P0008

Figure 10. Delivery Pan Assembly (Continued)

Snackvendor Models 159 - 160 Parts Manual

TABLE 38. DELIVERY PAN ASSEMBLY (CONTINUED)

INDEX	PART NUMBER	DESCRIPTION	QTY.
13	1472082	FILLER - DELIVERY PAN (159)	1
	1482159	FILLER - LEFT - GRAY (160)	
-	1451097	SCREW - #8-32 X .31 HEX HD.TF - BLK.	4
-	3108030	ACORN NUT	2
14	1472087	WASHER - .38 I.D. X .56 O.D	2
15	1472083	SPACER	2
16	4042556	CANOE CLIP	2
17	2342110	BRACKET - SPRING	1
18	1472068	BRACKET - DOOR PIVOT-R.H.	1
-	1170206	SCREW - #8-32 X 3/8 THS BLACK	1
-	9900081	NUT - #8-32 KEPS ZINC PLATE	1
19	4246044	SPRING - ELEVATOR GUIDE ARM	1
20	1572029	DEFLECTOR - PRODUCT - R.H.	1
-	1170206	SCREW - #8-32 X 3/8 THS BLACK	2
-	9900081	NUT - #8-32 KEPS ZINC PLATE	2
21	1412022	FILLER - RIGHT - BLACK	1
-	1306140	8-32 X 3/8 CARR BOLT BLK/OX	3
-	9900081	NUT - #8-32 KEPS ZINC PLATE	3
22	1472200	PAN - DELIVERY - FRONT - BLACK (159)	1
	1482187	PAN - DELIVERY - FRONT - BLACK (160)	
-	1306140	8-32 X 3/8 CARR BOLT BLK/OX (159)	5
		8-32 X 3/8 CARR BOLT BLK/OX (160)	4
-	9900081	NUT #8-32 KEPS ZINC PLATE (159)	5
		NUT #8-32 KEPS ZINC PLATE (160)	4
23	2342109	BUSHING - DELIVERY - LINKAGE	1
24	4402016	PLATE - DOOR RETENTION	1
25	1472156	ACTUATOR ASSEMBLY - RIGHT	1
-	9900146	RETAINING RING E TYPE .312	2
-	9900171	WASHER BRASS 9/16 X.315 X.040	2
26	1412047	ANGLE - DELIVERY DOOR (159)	1
	1462073	ANGLE - DELIVERY DOOR (160)	
27	1472271	ACTUATOR - DELIVERY DOOR - R.H. (159)	1
	1482251	ACTUATOR - DELIVERY DOOR - R.H. (160)	
-	1170206	SCREW - #8-32 X 3/8 THS BLACK	2
-	1412046	8-32 NUT MF 23TW832 BLOX	2
28	1472219	SPACER	2
29	1472088	LABEL - GUM & MINT SELECTIONS	1
30	1472105	PRICE LABELS - GUM & MINT (\$ AND ¢)	1

Snackvendor Models 159 - 160 Parts Manual

TABLE 39. GUM AND MINT UNIT (PART 1 OF 2)

INDEX	PART NUMBER	DESCRIPTION	QTY.
1	1407048	NUT - 10-32 M/F #21TWA1032 ZP (WITH GUM & MINT UNIT)	2
2	3108030	ACORN NUT - BRASS NICKEL 8-32 (WITHOUT GUM & MINT UNIT)	2
3	1479052	STUD - PIVOT - GUM AND MINT (WITH GUM & MINT UNIT)	2
4	1452139	RETAINER - HARNESS (WITH GUM & MINT UNIT)	1
5	1577000	GUM & MINT COLUMN (159)	1
	1587000	GUM & MINT COLUMN (160)	
6	1577001	ANGLE & MOTOR ASSEMBLY (159)	1
	1587001	ANGLE & MOTOR ASSEMBLY (160)	
7	1479136	FRAME ASSEMBLY - G & M (159)	1
	1489008	FRAME ASSEMBLY - G & M (160)	
	1479130	MAGAZINE ASSEMBLY - G & M (159)	
	1489006	MAGAZINE ASSEMBLY - G & M (160)	
8	1472082	FILLER - DELIVERY PAN (159)	1
	1482159	FILLER - DELIVERY PAN (160)	

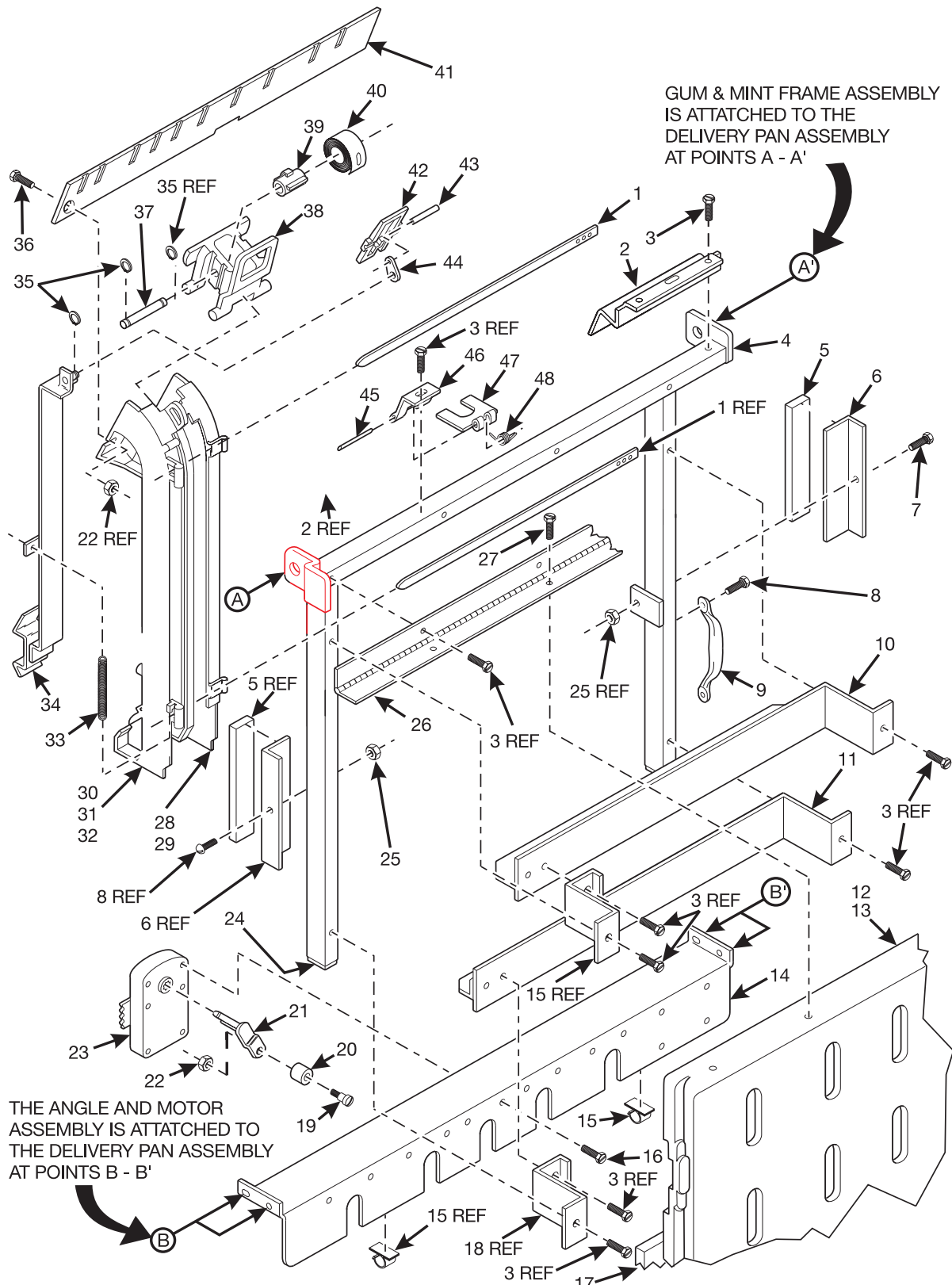

Snackvendor Models 159 - 160 Parts Manual

TABLE 40. GUM AND MINT UNIT (PART 1 OF 2)

INDEX	PART NUMBER	DESCRIPTION	QTY.
-	1577000	GUM & MINT COLUMN (159)	-
	1587000	GUM & MINT COLUMN (160)	
1	1579053	RETAINER	3
2	1479103	FILLER - GUM & MINT	2
3	1451097	SCREW - #8-32 X .31 HEX HD. TF	-
4	1479136	FRAME ASSEMBLY - GUM & MINT (159)	1
	1489008	FRAME ASSEMBLY - GUM & MINT (160)	
5	3122056	MAGNET RETAINER COIN CHANGER	2
6	1479117	ANGLE MAGNET	2
7	9900201	SCREW #8-32 X 5/16 RHS SEMS MACH ZINC	2
8	4041053	SCREW #10-32 X 3/8 PHS T/C W/LW	2
9	1479139	PULL - DOOR	1
10	1479089	SUPPORT ASSEMBLY - MAGAZINE - UPPER	1
11	1479092	SUPPORT ASSEMBLY - MAGAZINE - LOWER	1
12	1479101	COVER - GUM & MINT	1
13	1479124	LABEL - LOADING - GUM & MINT	1
14	1479102	ANGLE - MOTOR (159)	1
	1489005	ANGLE - MOTOR (160)	
15	6131143	CABLE CLAMP - RICHCO #KKC6	2
16	1457027	SCREW - #8-32 X .81 HEX HD. - T/F	10
17	1479119	MAGNET - RETAINER	2
18	1479095	BRACKET - MAGAZINE	2
19	1479062	STUD - DRIVE ARM	5
20	1479063	ROLLER - DRIVE ARM	5
21	1479145	ARM - DRIVE MOTOR	5
22	9900081	NUT - #8-32 KEPS ZINC PLATE	5
23	1577035	MOTOR & PC BOARD ASSEMBLY	5
24	1479120	CAPLUG - REC. 1/2 X 1	2
25	1412046	NUT - #8-32 MF 23TW832 BLOX	2
26	1479104	HINGE - COVER	1
27	1437204	SCREW - #8-10 X .38 HEX HD. TF	4
28	1479073	CHANNEL - GUM & MINT - LEFT	5
29	1479064	SPACER - COLUMN - GUM & MINT	2
30	1479076	CHANNEL - GUM & MINT - RIGHT - SMALL	3
31	1479077	CHANNEL - GUM & MINT - RIGHT - LARGE	2
32	1572040	LABEL - LOADING LINE - GUM & MINT	1
33	4246307	SPRING - HORIZONTAL SELECTOR ARM	5
34	1479123	DRIVE BAR & STUD ASSEMBLY	5
35	9900425	RETAINING RING - REINF. E TYPE .250	15

Snackvendor Models 159 - 160 Parts Manual

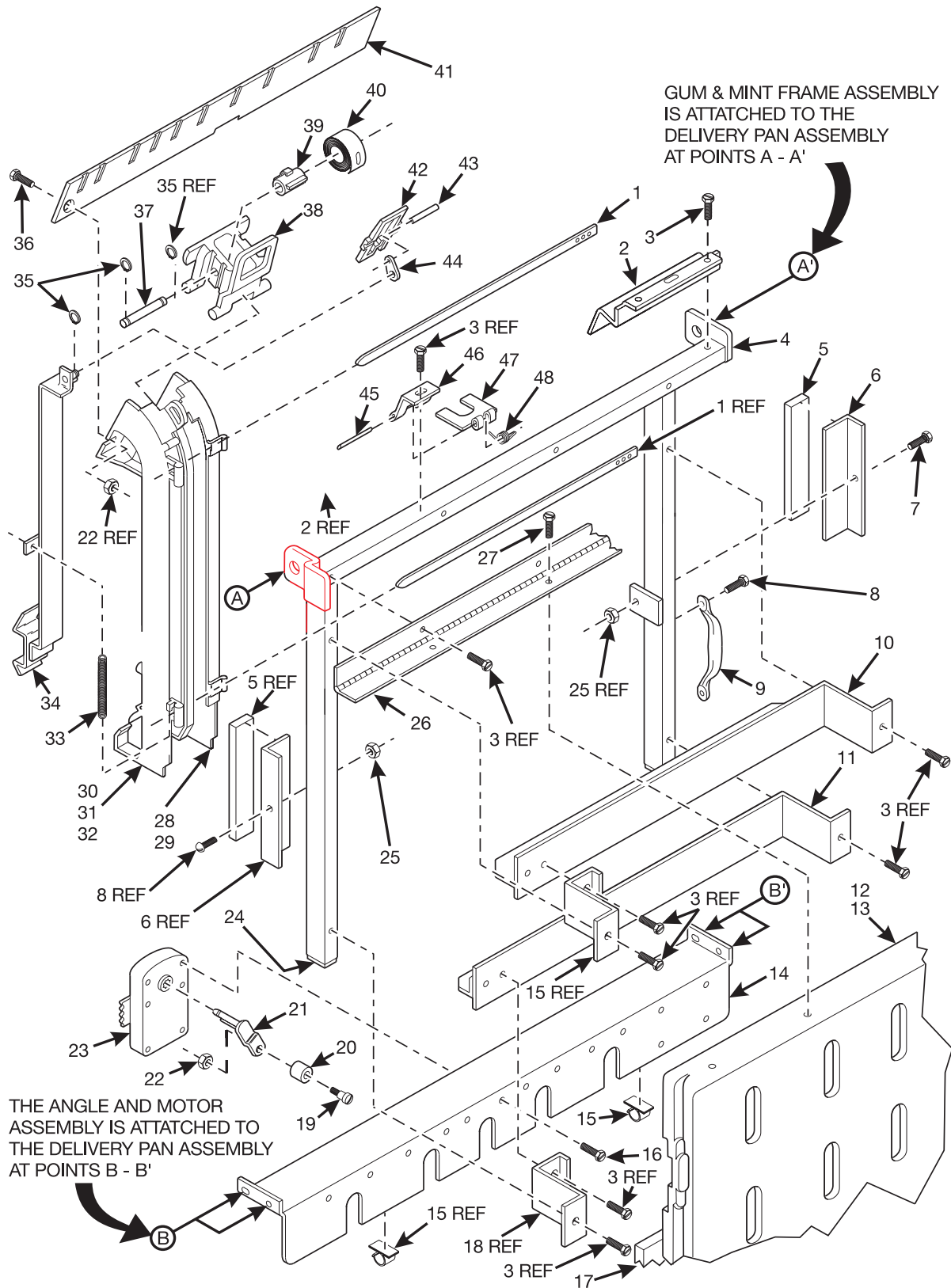

157P0116

Figure 12. Gum and Mint Unit (Part 1 of 2) (Continued)

Snackvendor Models 159 - 160 Parts Manual

TABLE 40. GUM AND MINT UNIT (PART 1 OF 2) (CONTINUED)

INDEX	PART NUMBER	DESCRIPTION	QTY.
36	9900020	SCREW #8-32 X 1/2 RHS MACH. ZINC	1
37	1479099	PIN - PUSHER	5
38	1479079	PUSHER	5
39	1479080	SPOOL - SPRING	5
40	1479106	SPRING - PUSHER	5
41	1479105	WINDOW - GUM & MINT	1
42	1479078	EJECTOR - GUM & MINT	5
43	1479098	PIN - EJECTOR	5
44	1479097	LINK - EJECTOR	5
45	1479083	PIN - HINGE	5
46	1479082	HINGE - BACK	5
47	1479081	HINGE - FRONT	5
48	1479084	SPRING - HINGE	5

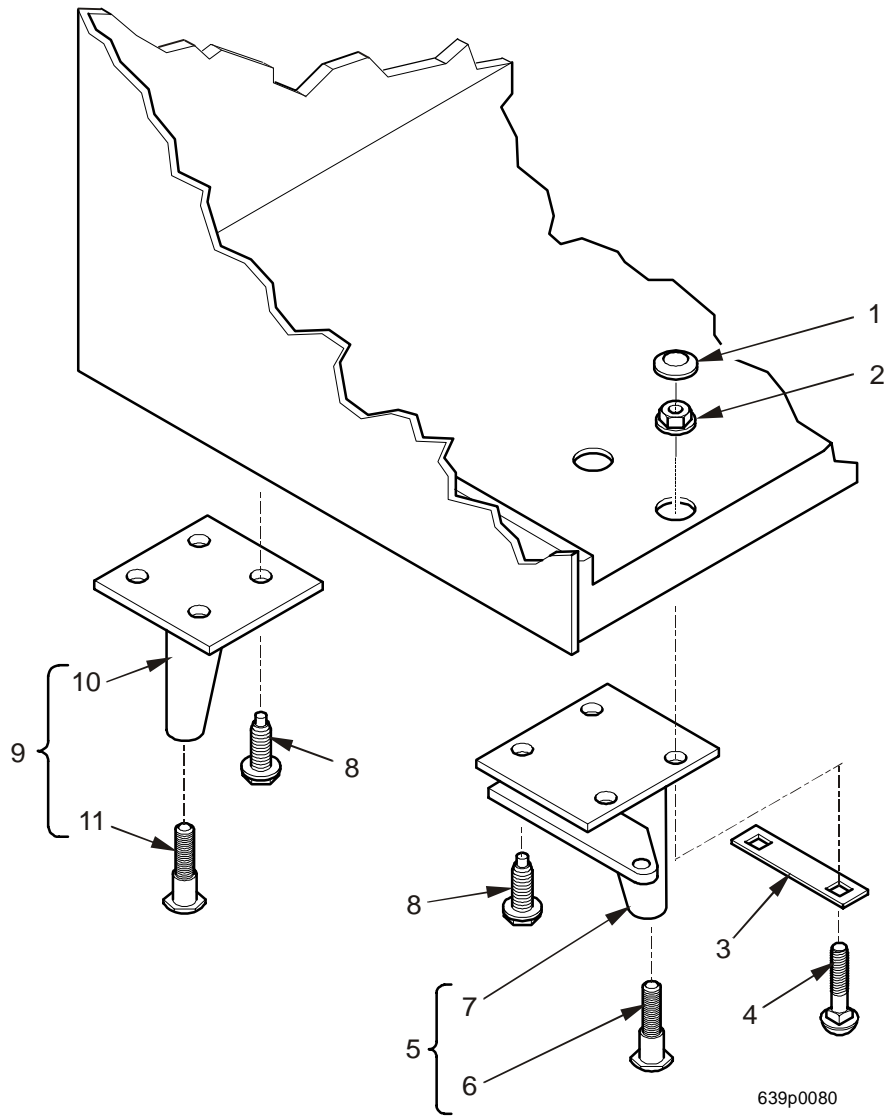

Figure 13. Leg, Leveler, and Leg and Hinge Assemblies

Snackvendor Models 159 - 160 Parts Manual

TABLE 41. LEG, LEVELER, AND LEG AND HINGE ASSEMBLIES

INDEX	PART NUMBER	DESCRIPTION	QTY.
1	6231034	PLUG - HOLE (NOT USED IN ALL APPLICATIONS)	2
2	1172021	NUT - 1/4-20 WHIZ-LOCK	2
3	6231203	PLATE - HINGE LEG BOLT	1
4	1211112	TRAY BOLT	2
5	6231163	LEG, HINGE, AND LEVELER ASSEMBLY	1
6	1471098	LEVELER - CABINET	1
7	1571115	LEG AND HINGE ASSEMBLY	1
8	9900218	SCREW - # 5/16 X 1 W/LOCKING RING	14
9	1471237	LEG AND LEVELER ASSEMBLY - CABINET	3
10	1571127	LEG ASSEMBLY - CABINET	1
11	1471098	LEVELER - CABINET	1

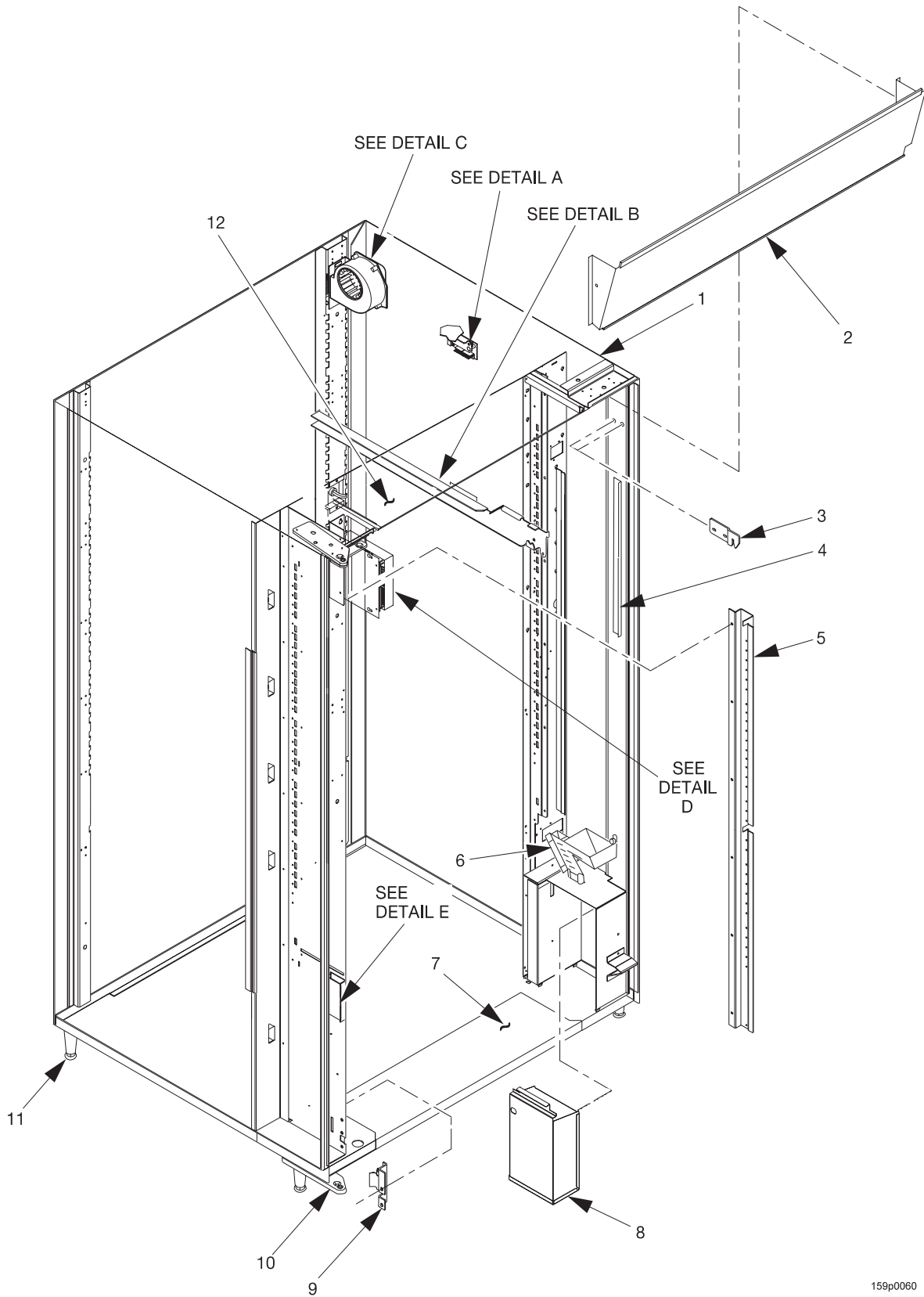

Figure 14. Common Cabinet (Part 1 of 4)

159p0060

Snackvendor Models 159 - 160 Parts Manual

TABLE 42. COMMON CABINET (PART 1 OF 4)

INDEX	PART NUMBER	DESCRIPTION	QTY.
1	1571185	CABINET ASSEMBLY - N.V.BLACK (159)	1
	1581058	CABINET ASSEMBLY - MILLENIA GRAY (160 CHINA STYLE)	
	1581055	CABINET ASSEMBLY - N.V.BLACK (160)	
2	1571102	PANEL - FILLER (159)	1
3	1571074	LOCK ARM - CABINET	2
4	1571022	STOP - MONETARY PANEL	2
5	1571119	RAIL MOUNTING CHANNEL - L.H.	1
6	6231242	CHUTE - PAYOUT	1
7	1571187	BASE FILLER ASSEMBLY - N.V. BLACK (159)	1
	1581057	BASE FILLER ASSEMBLY - N.V.BLACK (160)	
	1581060	BASE FILLER ASSEMBLY - MILLENIA GRAY (160 CHINA STYLE)	
8	1571029	MONEY BOX ASSEMBLY	1
9	1571090	PLATE ASSEMBLY - DOOR CHECK	1
10	6231163	LEG, HINGE & LEVELER ASSEMBLY	1
11	1471237	LEG & LEVELER ASSEMBLY - CABINET	3
12	1571186	TOP FILLER ASSEMBLY - N.V.BLACK (159)	1
	1581056	TOP FILLER ASSEMBLY - N.V.BLACK (160)	
	1581059	TOP FILLER ASSEMBLY - MILLENIA GRAY (160 CHINA STYLE)	

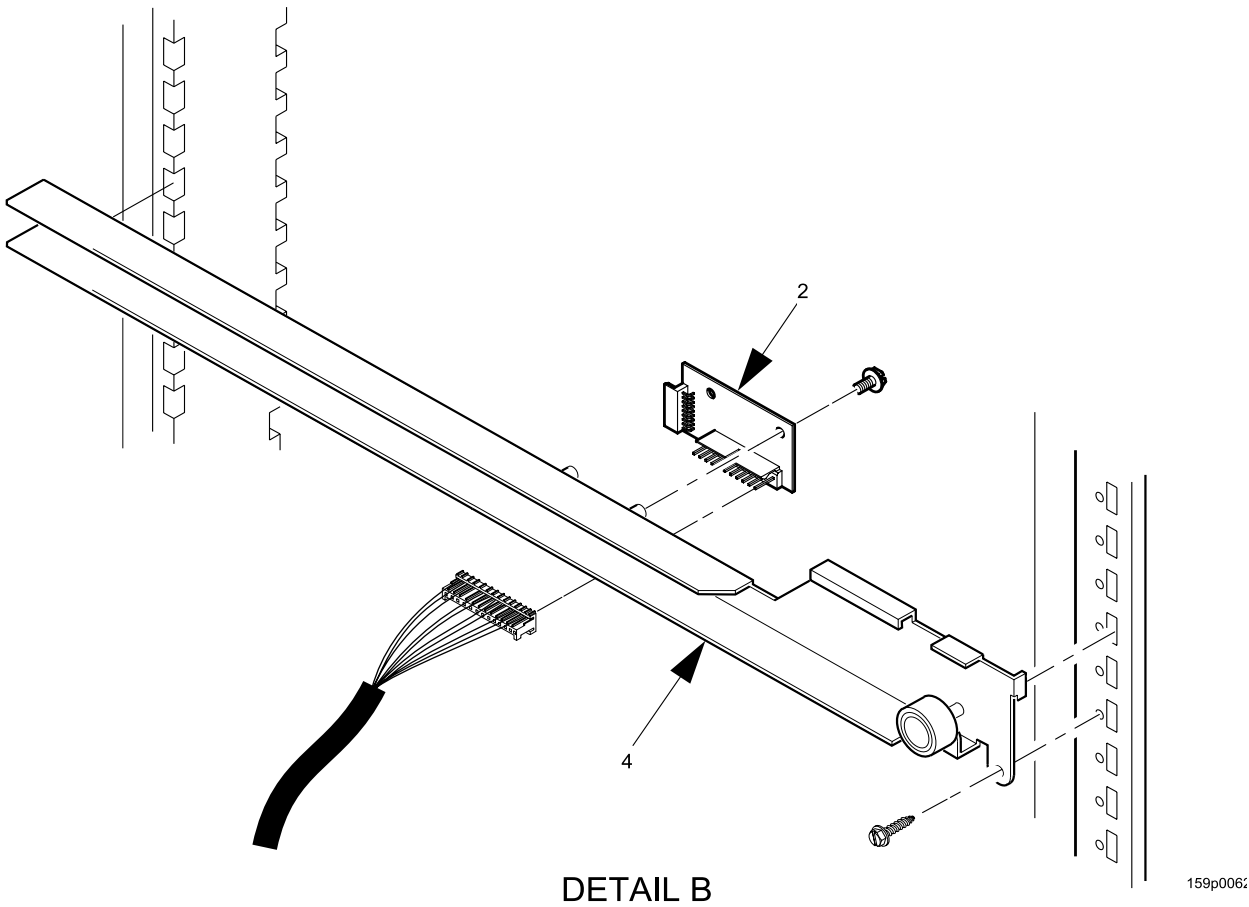
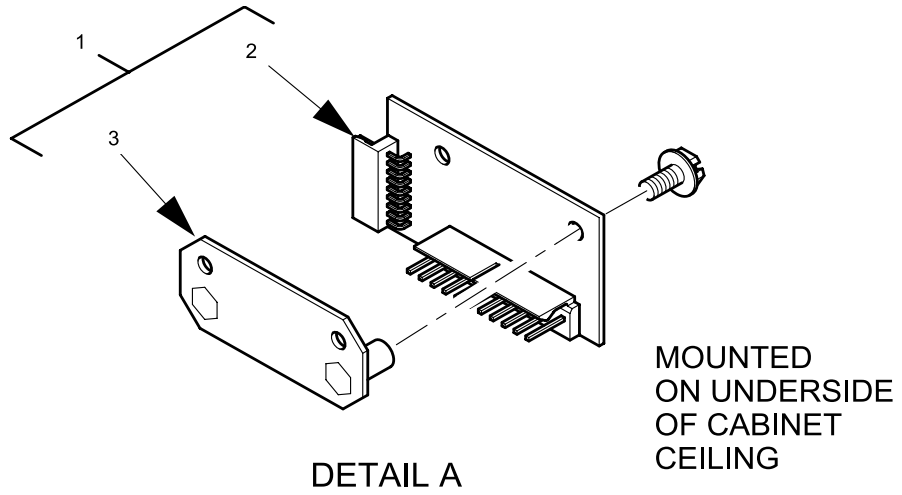

Figure 15. Common Cabinet (Part 2 of 4)

Snackvendor Models 159 - 160 Parts Manual

TABLE 43. COMMON CABINET (PART 2 OF 4)

INDEX	PART NUMBER	DESCRIPTION	QTY.
1	1571175	PLATE - PCB RAIL - MOUNTING	1
-	-	MOUNTING HARDWARE	2
2	1596012	PCB ASSEMBLY - TRAY	1
3	1451097	SCREW - #8-32 X .31 - HEX HD - T/F - BLACK	2
-	1571235	TRAY GUIDE RAIL/PCB ASSEMBLY - RIGHT HAND (INCLUDES INDEX NUMBERS 4-6)	*
4	1571179	TRAY GUIDE RAIL - W/STANDOFFS	1
5	1596012	PCB ASSEMBLY - TRAY	1
6	1451097	SCREW - #8-32 X .31 - HEX HD - T/F - BLACK	2
-	1571236	TRAY GUIDE RAIL ASSEMBLY - RIGHT HAND (TOP TRAY) (NOT SHOWN)	1
-	1571181	TRAY GUIDE RAIL ASSEMBLY - LEFT HAND (ALL TRAYS) (NOT SHOWN)	*

* = QUANTITY = 1 PER TRAY IN MACHINE

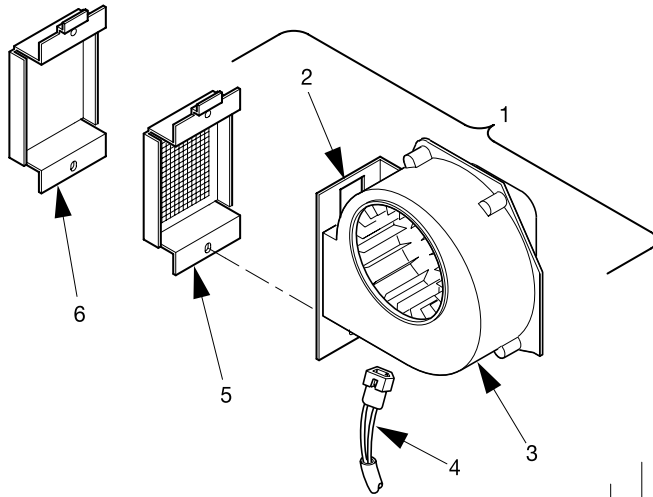

DETAIL C

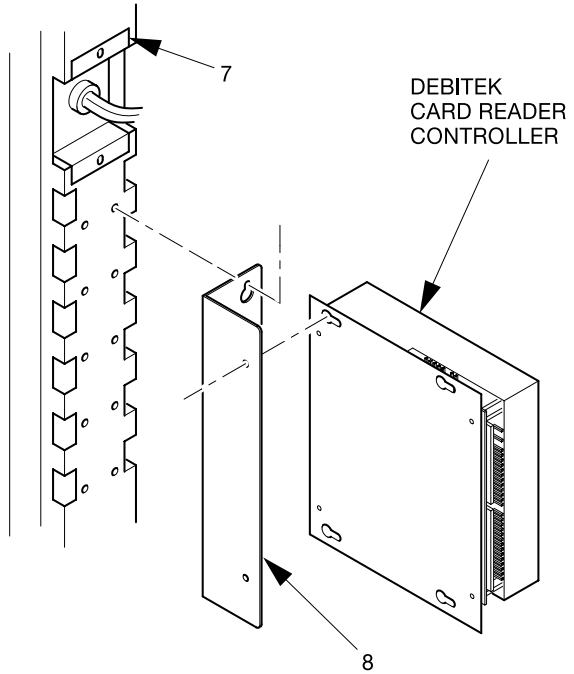

DETAIL D

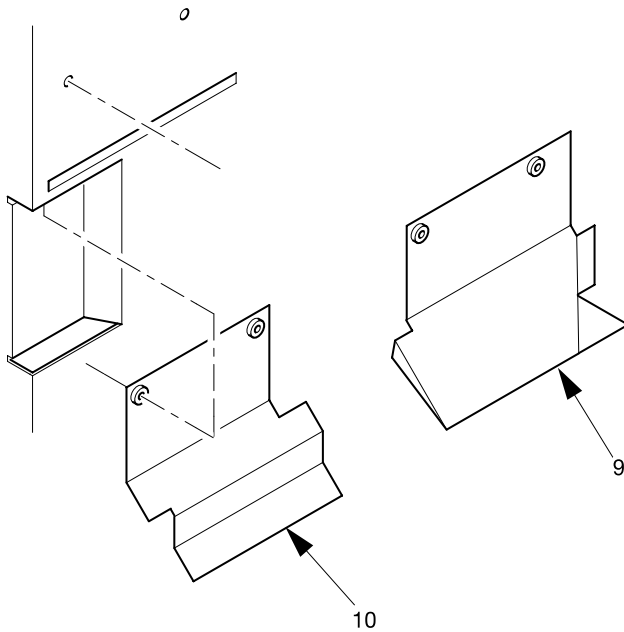

DETAIL E
Rotated 90 Degrees

159p0061

Figure 16. Common Cabinet (Part 3 of 4)

Snackvendor Models 159 - 160 Parts Manual

TABLE 44. COMMON CABINET (PART 3 OF 4)

INDEX	PART NUMBER	DESCRIPTION	QTY.
1	-	FAN OPTION	OPT.
2	1471398	BRACKET - EXHAUST FAN	1
3	6231548	BLOWER ASSEMBLY - 120V	1
	6401088	BLOWER ASSEMBLY - 230V	
4	9989637	JUMPER - BLOWER	1
5	1471054	BRACKET & SCREEN ASSEMBLY - EXHAUST	1
6	1471090	COVER - FAN HOLE (NO FAN OPTION ONLY)	OPT.
7	1471065	BRACKET - MOUNTING - POWER CORD	1
8	1575050	BRACKET - DEBITEK CONTROLLER	1
9	1581039	DEFLECTOR ASSEMBLY - SMALL SNACK (160)	1
10	1571123	DEFLECTOR - LARGE SNACK (159)	1

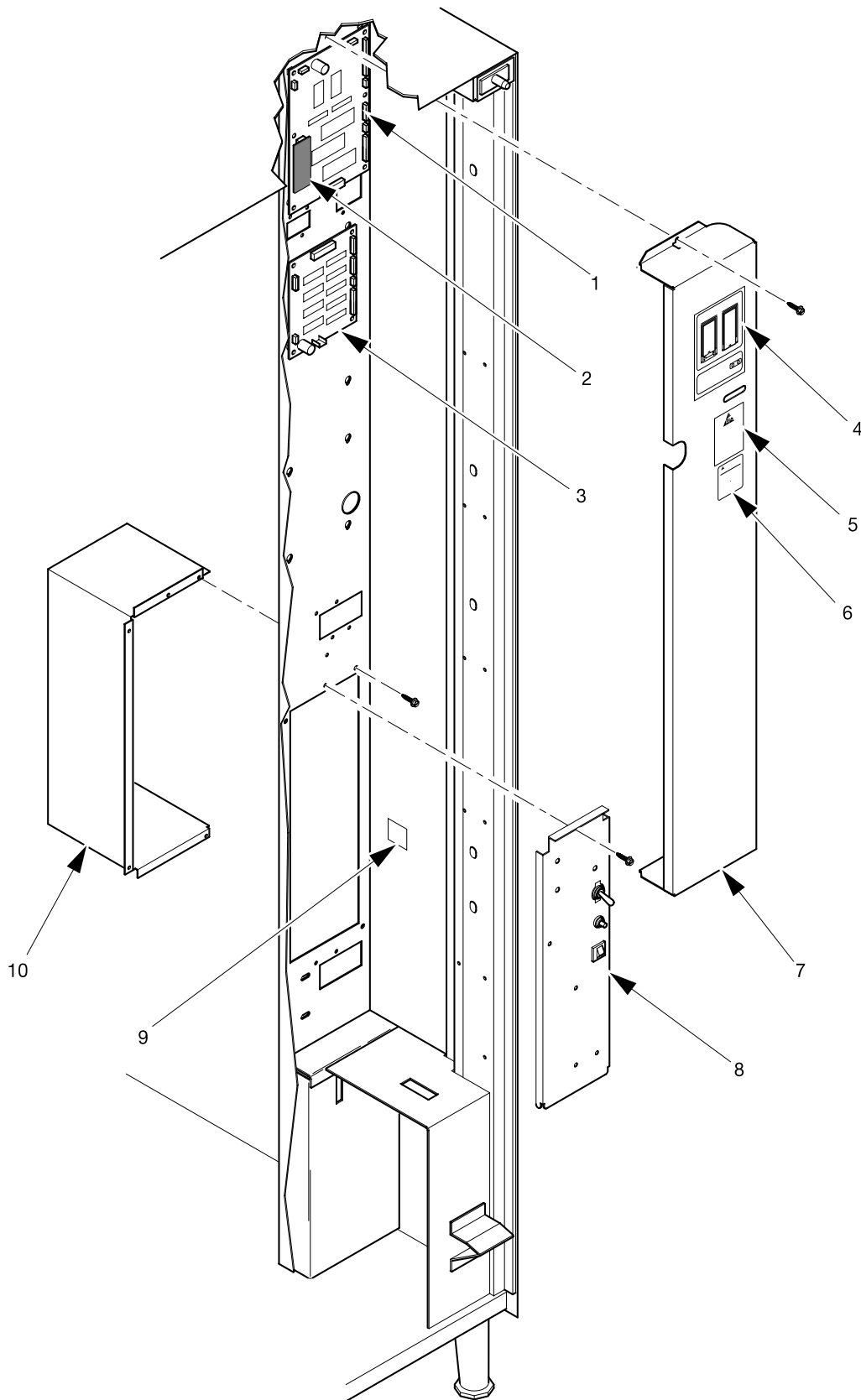
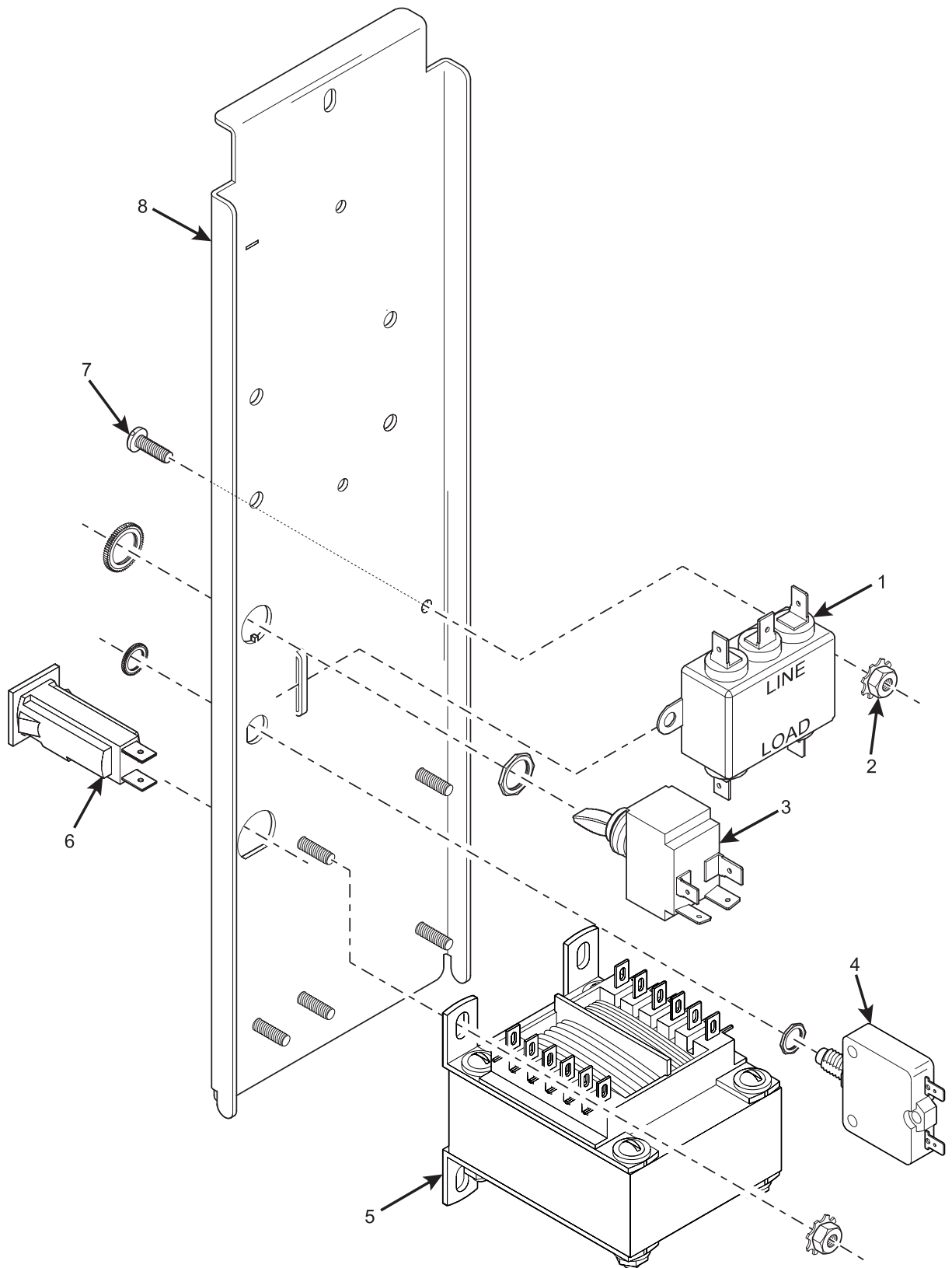

Figure 17. Common Cabinet (Part 4 of 4)

Snackvendor Models 159 - 160 Parts Manual

TABLE 45. COMMON CABINET (PART 4 OF 4)

INDEX	PART NUMBER	DESCRIPTION	QTY.
-	1606000	MAIN CONTROL PCB - WITH EPROM (INCLUDES ITEMS 1 AND 2)	1
1	9989678	PCB ASSEMBLY - MAIN CONTROLLER	1
2	SEE LABEL	IC ASSEMBLY	1
3	1576008	PCB ASSEMBLY - SNACK INTERFACE	1
4	1571042	LABEL - LED & EPROM - ENGLISH	1
	1571045	LABEL - LED & EPROM - SPANISH	
5	1571154	LABEL - CAUTION - STATIC/ELECT. CONN	1
	1571167	LABEL - CAUTION - STATIC/ELEC. CONN. - SPANISH	
6	6231189	LABEL - WARNING - HIGH VOLTAGE - ENGLISH	1
	6232290	LABEL - WARNING - HI VOLTAGE - SPANISH	
7	1571112	COVER - CONTROL/INTERFACE PCB	1
8	1571080	POWER PANEL ASSEMBLY - 115 V (S.A./U.S.) (SEE FIGURE 18 FOR DETAILS)	1
	1571084	POWER PANEL ASSEMBLY - 230V (CHN./S.A.)FIGTITLE: FIGURE 20 . POWER PANEL ASSEMBLY - 230 VOLT	
	1571136	POWER PANEL ASSEMBLY - 120 V EXEC. (MEX) (SEE FIGURE 19 FOR DETAILS)	
9	4761148	LABEL - EARTHING	1
10	1571032	HOUSING - POWER PANEL	1



170P0036

Figure 18. Power Panel Assembly - 115 Volt

Snackvendor Models 159 - 160 Parts Manual

TABLE 46. POWER PANEL ASSEMBLY - 115 VOLT

INDEX	PART NUMBER	DESCRIPTION	QTY.
-	1701015	POWER PANEL ASSEMBLY - DOMESTIC	-
1	9989100	INTERFERENCE FILTER	1
2	9900081	NUT - #8-32 KEPS ZINC PLATE	6
3	9984629	SWITCH - TOGGLE - DPST - 20 AMP	1
4	9989672	BREAKER - 15 AMP	1
5	9989046	24 V TRANSFORMER - DUAL PRI. - .187 TERM	1
6	9989674	CIRCUIT BREAKER - 4 AMP	1
7	1211110	8-32 X 1/4 RHS MACH SCREW - Z.P.	6
8	1701025	PLATE - HOUSING - PANEL	1
-	6849015	JUMPER - POWER SWITCH (MEXICO) (NOT SHOWN)	1
-	9989110	FILTER - POWER LINE - EMI (MEXICO) (NOT SHOWN)	1

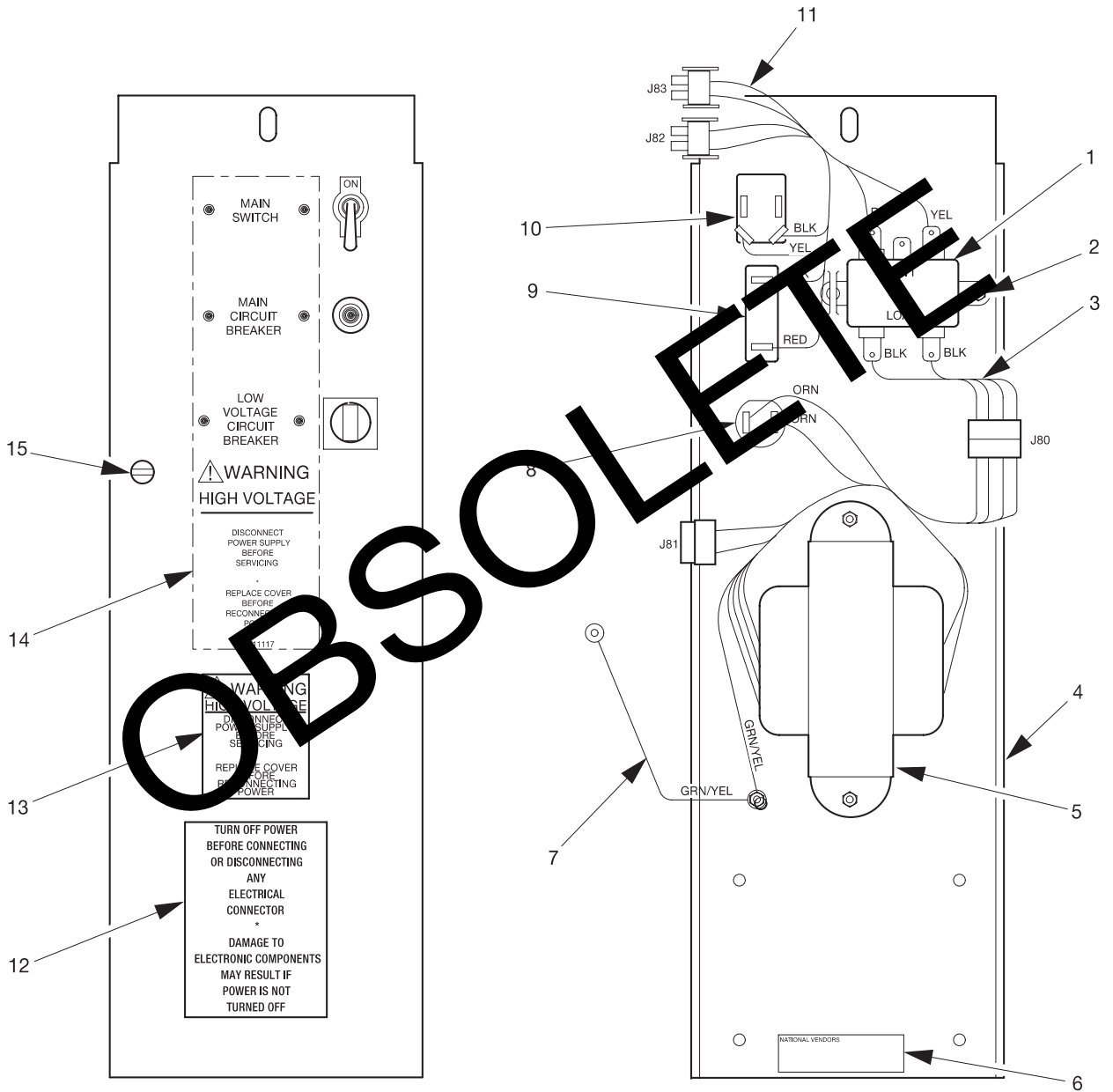

159p0049

Figure 19. Power Panel Assembly - 120 Volt Exec.

Snackvendor Models 159 - 160 Parts Manual

TABLE 47. POWER PANEL ASSEMBLY - 120 VOLT EXEC.

INDEX	PART NUMBER	DESCRIPTION	QTY.
-	1571136	POWER PANEL ASSEMBLY - 120V - EXEC.	-
1	9989100	EMI FILTER	1
2	9900081	NUT - #8-32	3
3	1579020	JUMPER - 120 VOLT TO TRANSFORMER	1
4	1571129	PLATE AND STUD ASSEMBLY	1
5	9989042	TRANSFORMER - 115/230 V PRIMARY - 24 V SECONDARY	1
6	9989369	LABEL - ASSEMBLY ID NUMBER	1
7	9984165	JUMPER - GROUND WIRE	1
8	9989336	BREAKER - 3 AMP	1
9	9989673	BREAKER - 20 AMP	1
10	9984629	SWITCH - TOGGLE - DPST - 20 AMP	1
11	1579013	HARNESS - POWER PANEL DOMESTIC	1
12	1571167	LABEL - CAUTION - ELECTRICAL CONNECTIONS - SPANISH (ENGLISH TRANSLATION SHOWN)	1
13	6232290	LABEL - WARNING - HIGH VOLTAGE - SPANISH (ENGLISH TRANSLATION SHOWN)	1
14	1571128	LABEL - POWER CONTROL PANEL - SPANISH (ENGLISH TRANSLATION SHOWN)	1
15	1211110	#8-32 X 1/4 - R.H. MACHINE SCREW	1

OBSOLETE

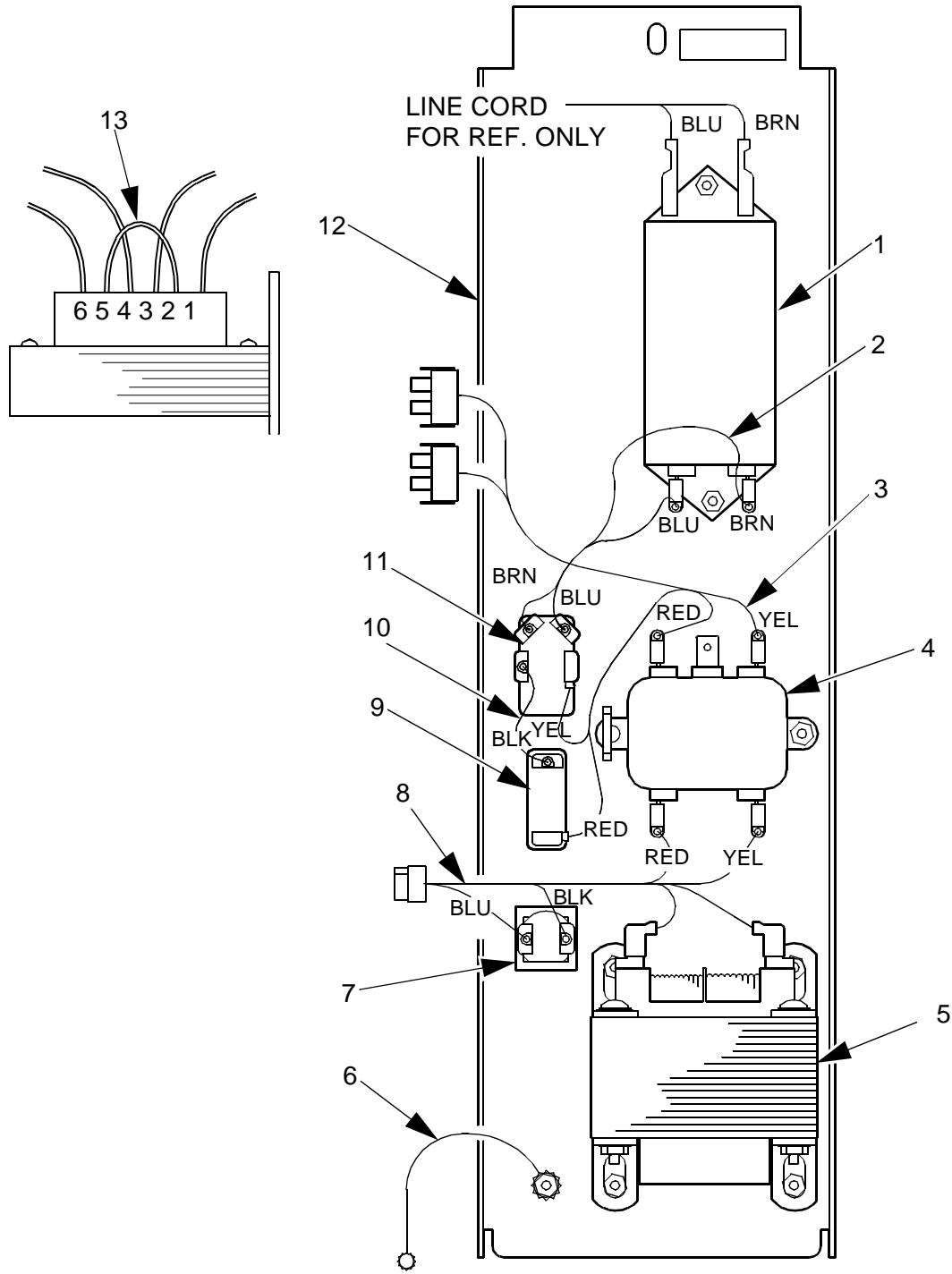

167p0007

Figure 20. Power Panel Assembly - 230 V.

Snackvender Models 159 - 160 Parts Manual

TABLE 20. POWER PANEL ASSEMBLY - 230 V.

INDEX	PART NUMBER	DESCRIPTION	QTY
-	4521020	POWER PANEL ASSY-U.K.-230V	-
1	9989110	MAIN LINE FILTER	1
2	6849015	JUMPER	1
3	1709000	HARNESS	1
4	9989100	E.M.I. FILTER	1
5	9989046	24V XFMR-DUAL PIR.-.187 TERM.	1
6	9984094	GROUND WIRE	1
7	9989674	BREAKER - 4A	1
8	1709001	HARNESS	1
9	9989672	BREAKER-15A	1
10	1709006	JUMPER	1
11	9984629	SWTICH	1
12	1701025	PLATE-HOUSING-PANEL	1
13	4279001	JUMPER	1

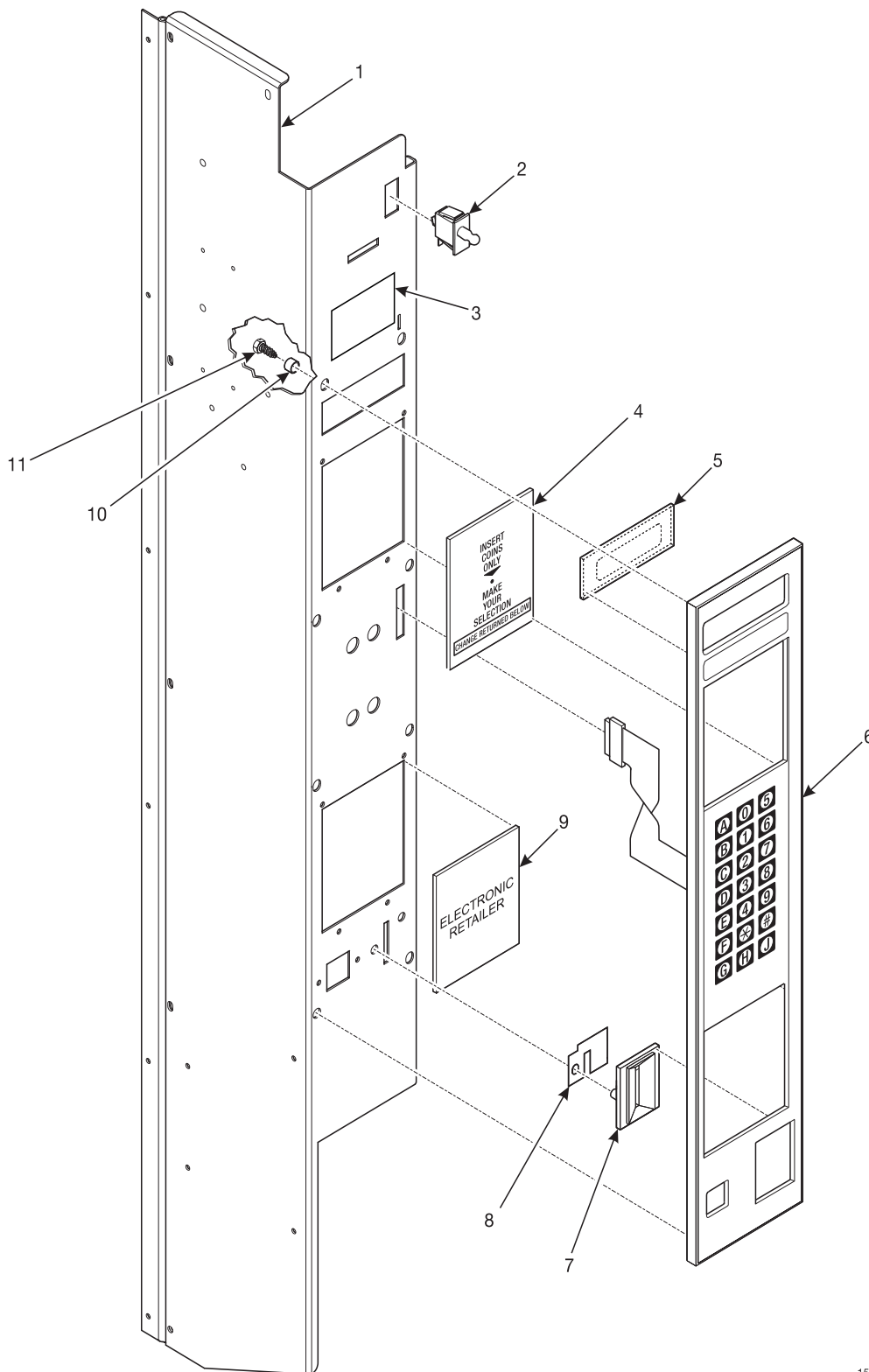

159P0044

Figure 21. Monetary Panel Assembly (Part 1 of 4)

Snackvendor Models 159 - 160 Parts Manual

TABLE 48. MONETARY PANEL ASSEMBLY (PART 1 OF 4)

INDEX	PART NUMBER	DESCRIPTION	QTY.
1	1575094	MONETARY PANEL WELD ASSEMBLY (SEE FIGURE 23 FOR DETAILS)	1
2	9989594	SWITCH - PUSH/PULL - PANEL MOUNTING	1
3	1590033	LABEL - INSTRUCTIONS - DATA - PRICE - PAYOUT	1
4	-	MONETARY INSERT - UPPER POSITION (SEE FIGURE 25 FOR DETAILS)	-
5	1595014	LENS - DISPLAY - GPL	1
6	1595017	FACE PLATE ASSEMBLY - GPL (SEE FIGURE 24 FOR DETAILS)	OPT.
7	1472223	COIN INSERT	1
8	1472222	COIN BLOCK	1
9	-	MONETARY INSERT - LOWER POSITION (SEE FIGURE 51 A FOR DETAILS)	-
10	2302053	CUP SPACER	-
11	-	SCREW	-

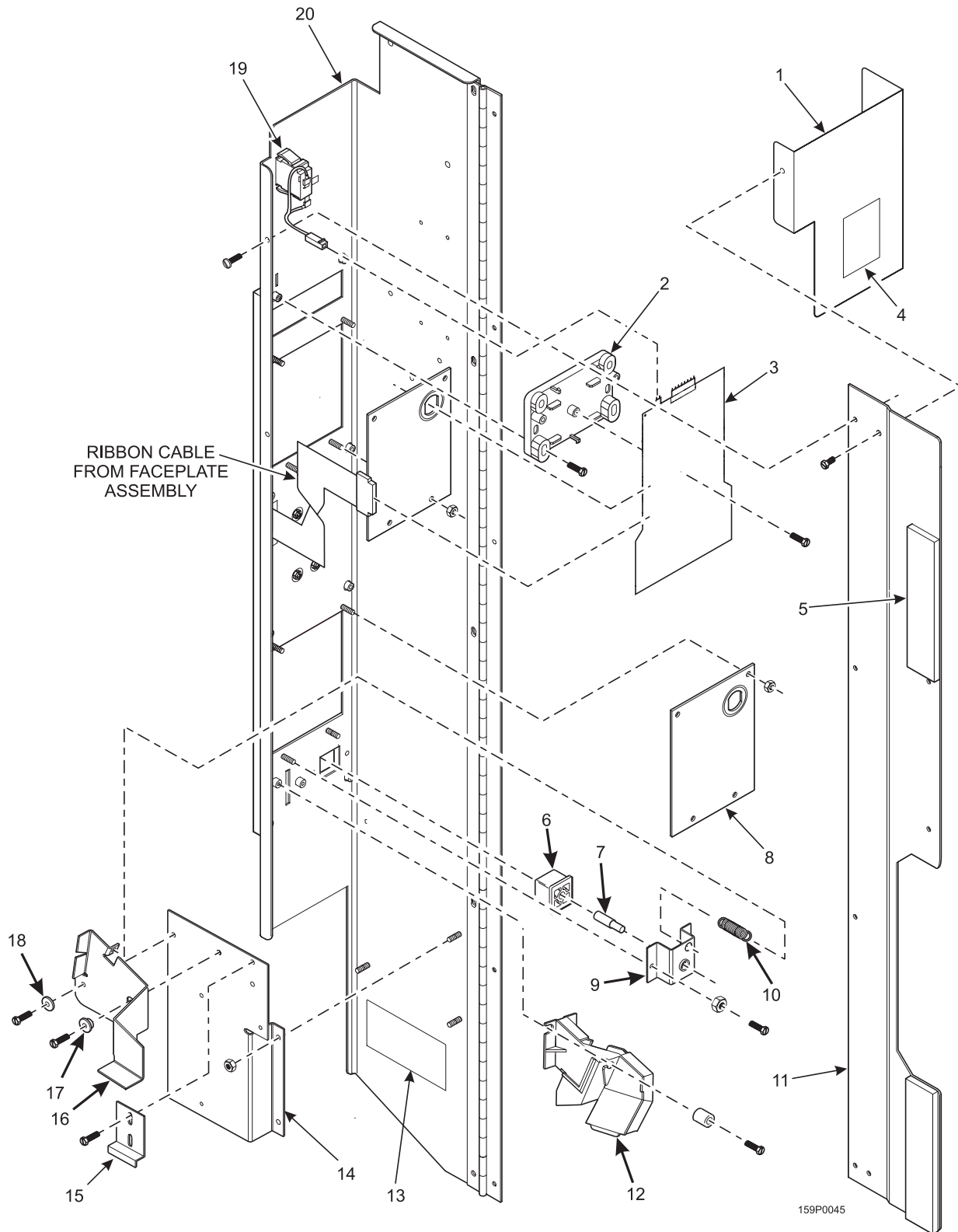
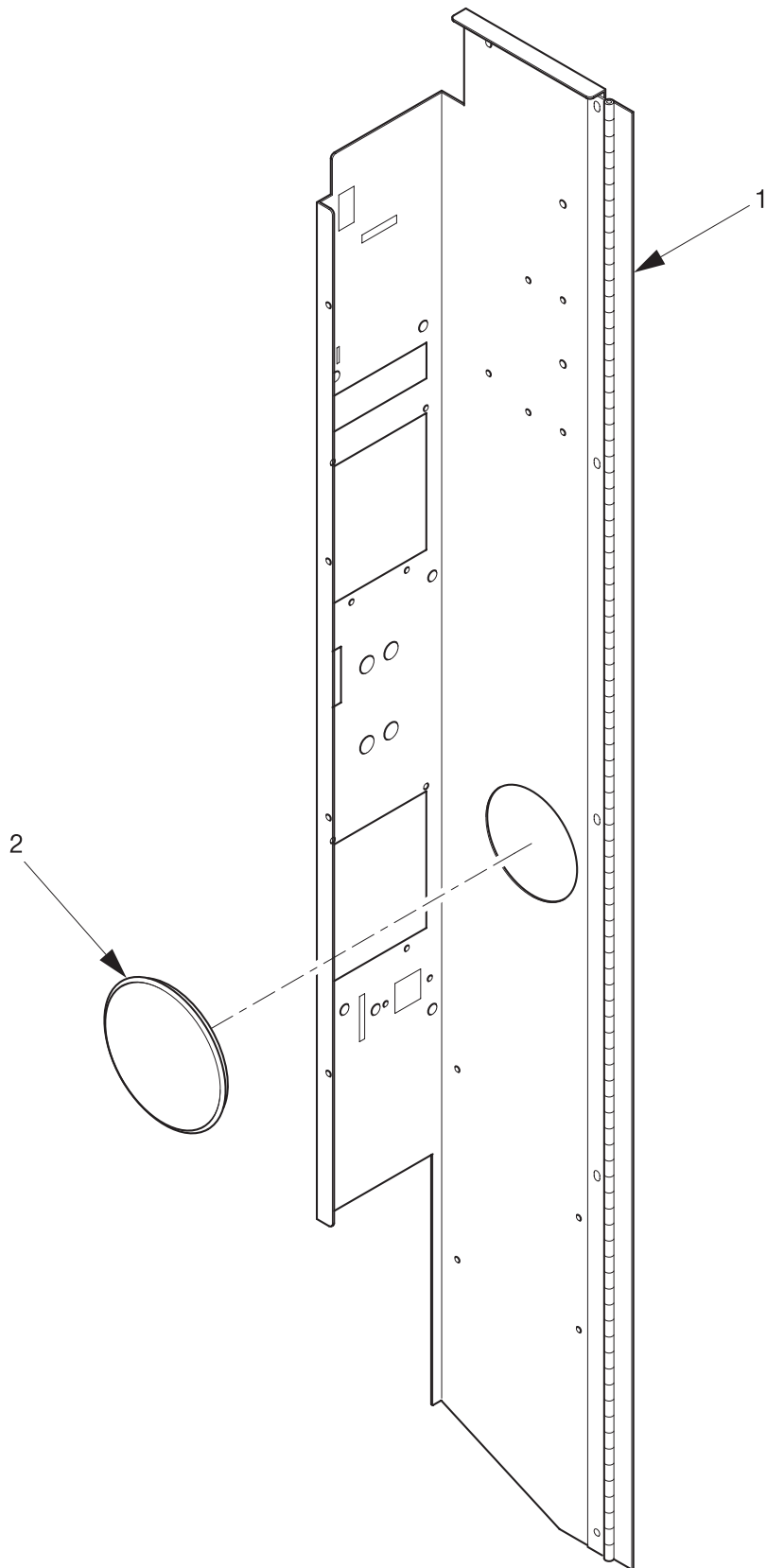

Figure 22. Monetary Panel Assembly (Part 2 of 4)

Snackvendor Models 159 - 160 Parts Manual

TABLE 49. MONETARY PANEL ASSEMBLY (PART 2 OF 4)

INDEX	PART NUMBER	DESCRIPTION	QTY.
1	1595029	COVER - DISPLAY	1
2	1475099	BRACKET - PCB DISPLAY	1
3	9989685	PCB ASEMBLY - DISPLAY	1
4	1571154	LABEL - CAUTION - STATIC/ELECT CONNECTION - ENGLISH (CHN./U.S.)	1
	1571167	LABEL - CAUTION - ELECTRICAL CONNECTION - SPANISH	1
	6232291	LABEL - CAUTION - STATIC - SPANISH	1
5	3122056	MAGNET - COIN CHANGER RETAINER	1
6	1475026	BUTTON - COIN RETURN	2
7	1475072	SHAFT - RETURN BUTTON	1
8	1575048	PLATE - INSERT BACKING (SEE FIGURE 52 FOR DETAILS)	-
9	1571079	BRACKET - COIN RETURN BUTTON	1
10	1127808	SPRING - SHELF RESET	1
11	1575057	PLATE - MAGNET MOUNTING	1
12	1575003	COIN CHUTE ASSEMBLY	1
13	1570105	LABEL - COIN MECHANISM - 120 V	1
14	1571078	BRACKET - COIN MECHANISM	1
15	6231037	CLAMP - CABLE	1
16	1571113	ARM - SCAVENGER	1
17	2228011	SPACER - RELEASE ARM	1
18	2204093	WASHER - SCAVENGER BAR	1
19	9989594	SWITCH - PUSH/PULL - PANEL MOUNTING	REF.
20	1575094	MONETARY PANEL WELD ASSEMBLY	REF.



159p0054

Figure 23. Monetary Panel Assembly (Part 3 of 4)

Snackvendor Models 159 - 160 Parts Manual

TABLE 50. MONETARY PANEL ASSEMBLY (PART 3 OF 4)

INDEX	PART NUMBER	DESCRIPTION	QTY.
1	1605000	PANEL WELD ASSEMBLY - MONETARY (CHN)	1
2	5004561	PLUG - HOLE - 4 INCH	1

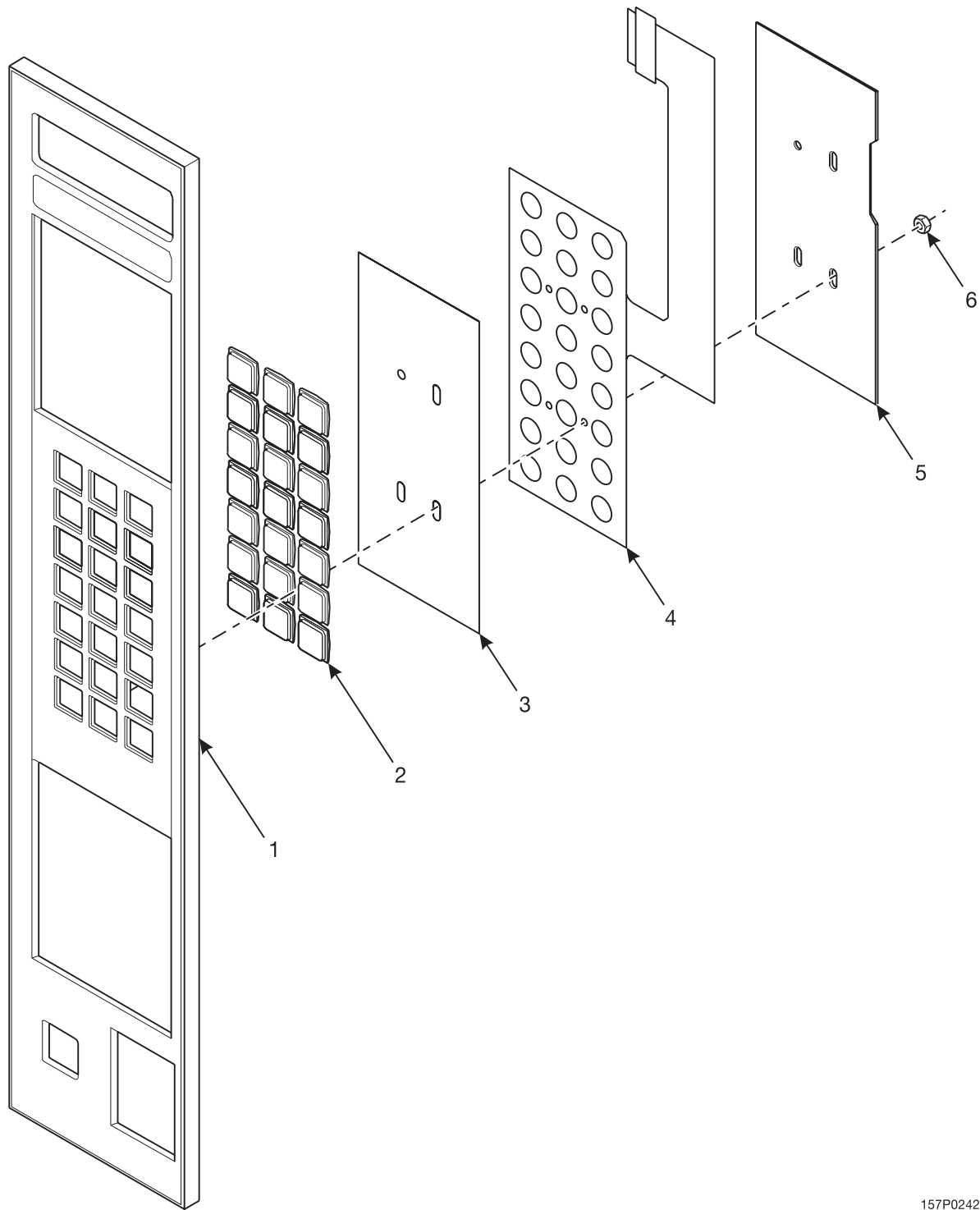

157P0242

Figure 24. Monetary Panel Assembly (Part 4 of 4)

Snackvendor Models 159 - 160 Parts Manual

TABLE 51. MONETARY PANEL ASSEMBLY (PART 4 OF 4)

INDEX	PART NUMBER	DESCRIPTION	QTY.
-	1595017	FACEPLATE ASSEMBLY - GPL	1
1	1595013	FRAME - MONETARY PANEL - GPL	1
2	1472251	LENS-PUSH BUTTON	21
3	1595002	LETTER SHEET - SELECT SWITCH - GLASCO	1
	1575010	LETTER SHEET - SELECT SWITCH - GPL (SMITH'S ONLY)	
4	9984630	MEMBRANE SWITCH ASSY-SELECT	1
5	1575091	PLATE-SELECT SWITCH-BACK UP - W/STUD	1
6	1475089	NUT	4

TABLE 51 A. MONETARY INSTRUCTION INSERTS

COUNTRY	LANGUAGE	MONETARY OPTION	UPPER INSERT	LOWER INSERT
USA CHINA	ENGLISH	COIN & BILL	1575012	N/A
		COIN & CARD	1575013	*
		COIN ONLY	1575013	1575035
SOUTH AMERICA	SPANISH	COIN & BILL	1595007	N/A
		COIN ONLY	1595005	1595012
		TOKEN ONLY	1595008	1595011
MEXICO	SPANISH	COIN ONLY	1575015	1575040

*** THE CARD READER IS NORMALLY IN THE LOWER MONETARY POSITION.**

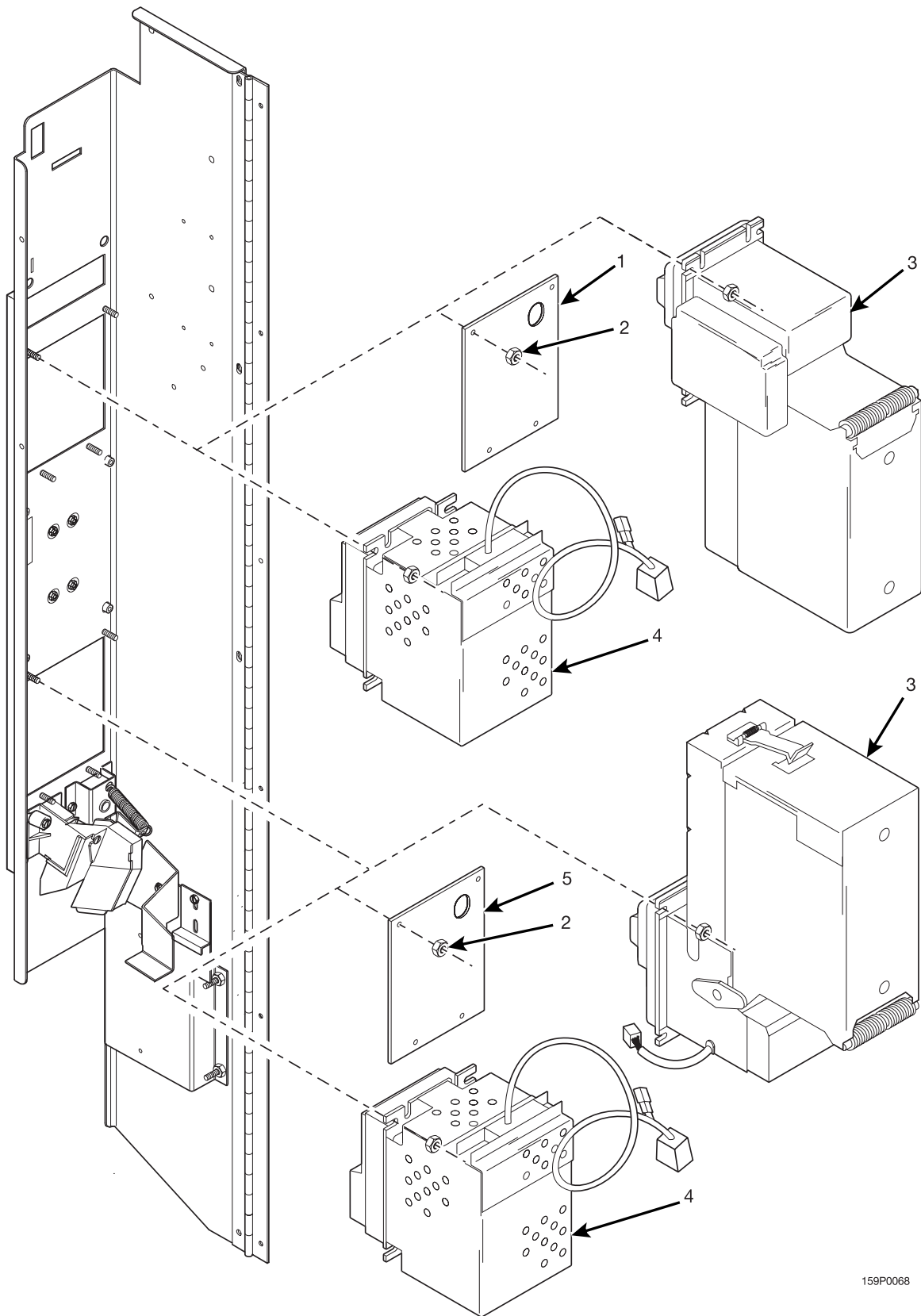

Figure 25. Card Reader and Bill Validator Combinations

Snackvender Models 159 - 160 Parts Manual

TABLE 52. CARD READER AND BILL VALIDATOR COMBINATIONS

INDEX	PART NUMBER	DESCRIPTION	QTY.
1	1575048	BACK-UP PLATE - COIN ONLY APPLICATION	2
2	9900081	NUT - #8-32 KEPS - ZINC PLATE	8
3	-	BILL VALIDATOR	OPT.
4	-	CARD READER	OPT.
5	1575048	BACK-UP PLATE - COIN & CARD/TOKEN & CARD	1

Snackvendor Models 159 - 160 Parts Manual

TABLE 52 A. BILL VALIDATOR OPTIONS

PART NUMBER	DESCRIPTION	USE WITH HARNESS PART NUMBER
5900198	VALIDATOR - MARS - S2000 - VN 2311 - U5E	1579005
5900182	VALIDATOR - COINCO - BA305A	1579028
5900193	VALIDATOR - MARS - S2000 - VN 2511 - U5E - CN5	
5900233	VALIDATOR - CONLUX MKA 2152-12B 120V	
5900239	VALIDATOR - GPT - CHINA	-
5900205	VALIDATOR - MARS - VN2512-U5E - 24V	1579032 (HARNESS) 9989718 (JUMPER)
5900221	VALIDATOR - COINCO - BA32SA - 24V	
5900234	VALIDATOR - CONLUX - 2162 - 24V - 300	
1475053	VALIDATOR - MAKA - NB - 1KB - 400 WITH MASK "K" INSTALLED	1579006
5900248	VALIDATOR - MARS AE 2611 - U5E - SERIAL	1579028
MDB VALIDATOR OPTIONS		
5900182	VALIDATOR - COINCO - BA 30SA	1579034
5900210	VALIDATOR - MARS - VN 2512 - USM/500 - MDB	-
5900234	VALIDATOR - CONLUX - 2162 - 24V - 300	1579050
5900247	VALIDATOR - MARS AE2612 - U5M - MDB	-

TABLE 52 B. CARD READER OPTIONS

PART NUMBER	DESCRIPTION
1475107	DEBITEK #VIS-MM-NAT SYSTEM III
1575050	BRACKET - DEBITEK CONTROLLER

Snackvendor Models 159 - 160 Parts Manual

TABLE 52 C. COIN MECHANISM OPTIONS

PART NUMBER	DESCRIPTION
5900116	MARS TRC6000 COIN UNIT
5307321	COINTRON 3000 - US COIN VAL
5900096	COINCO 9340L COIN UNIT
5900112	MARS MC5000 COIN UNIT
6400002	COIN CHANGER - MARS #TRC 6010XV
6400003	COIN CHANGER - COINCO # 9302LF-24
5900094	COINCO 9300L COIN UNIT
5900192	COIN UNIT - CONLUX USLX00401F
5900212	COIN UNIT - MARS TRC 6510 - MDB
5900213	COIN UNIT - COINCO - 9302 - GX - MDB
5900209	COIN UNIT - CONLUX - USLZ - 001 - MDB
5900214	COIN UNIT - MARS - VN 4510 - MDB
5900216	COIN UNIT - MARS - VN 4000, 110V
5900217	COIN UNIT - MARS - VN 4010 XV - 24V
5900192	COIN UNIT - CONLUX USLX 00401F
5900237	COIN UNIT - CONLUX USLX - 001 120V
1600851	MARS CASH FLOW - MDB - CHINA
5900240	COIN UNIT - C.F. MDB - CUSTOMER SUPPLIED

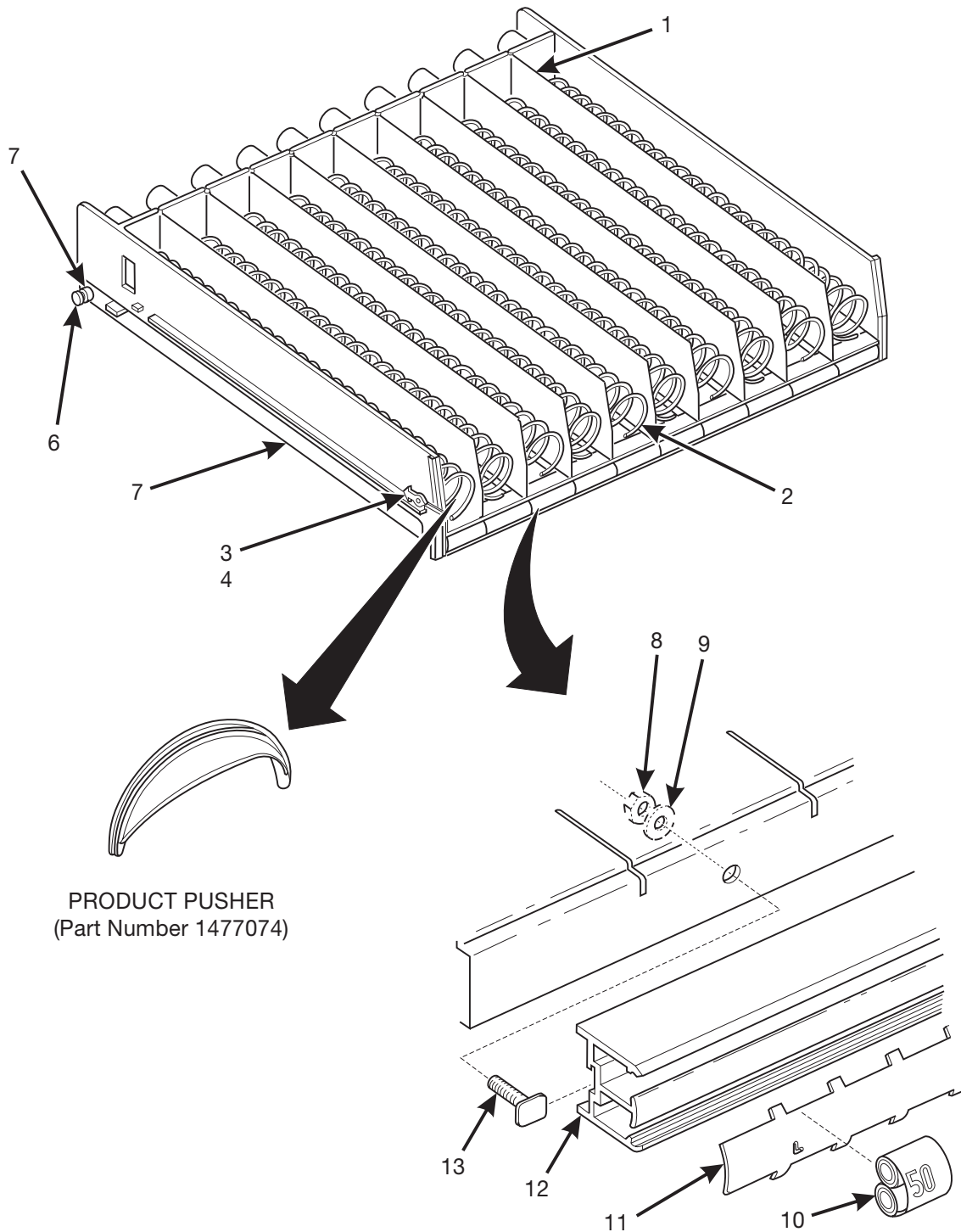
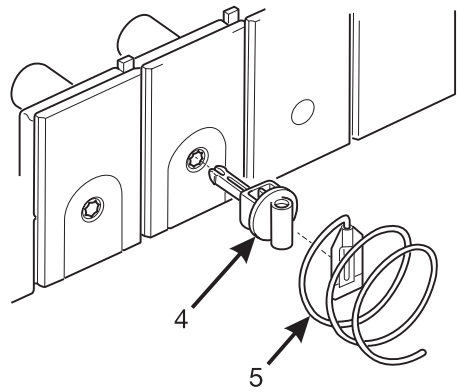
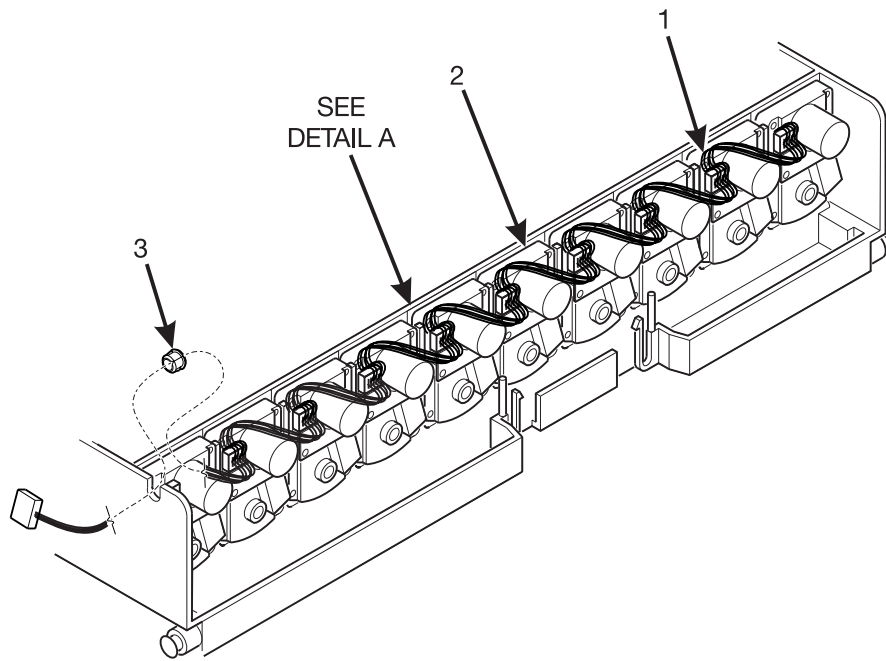

Figure 26. Candy Tray Assembly (Part 1 of 2)

Snackvendor Models 159 - 160 Parts Manual

TABLE 53. CANDY TRAY ASSEMBLY (PART 1 OF 2)

INDEX	PART NUMBER	DESCRIPTION	QTY.
-	1597002	TRAY ASSEMBLY - 10 CANDY (SHOWN)	1
	1607002	TRAY ASSEMBLY - 8 CANDY (NOT SHOWN)	
1	1477175	WALL - TRAY (159)	9
		WALL - TRAY (160)	7
2	-	SPIRAL (SEE TABLE 58 A FOR DETAILS)	-
3	1477017	LATCH	2
4	5201267	PUSH ON RETAINER - .312	2
5	1577040	TRAY - 5 & 10 DIVISION (159)	1
	1587003	TRAY - 4 & 8 DIVISION (160)	
6	1477097	AXLE - TRAY ROLLER	2
7	1477148	ROLLER - TRAY	2
8	9900030	NUT #8-32 SELF-LOCKING (159)	3
		NUT #8-32 SELF-LOCKING (160)	2
9	5560113	WASHER - HOPPER RELEASE (159)	3
		WASHER - HOPPER RELEASE (160)	2
10	1477014	ROLL - PRICE - CENTS (159)	10
		ROLL - PRICE - CENTS (160)	8
11	1477157	HOLDER - PRICE & SELECTION (159)	1
	1487016	HOLDER - PRICE & SELECTION (160)	
12	1477134	RAIL - PRICE & SELECTION (159)	1
	1487009	RAIL - PRICE & SELECTION (160)	
13	2222031	TEE BOLT - TRIM (159)	3
		TEE BOLT - TRIM (160)	2



159PO025

DETAIL A

Figure 27. Candy Tray Assembly (Part 2 of 2)

Snackvendor Models 159 - 160 Parts Manual

TABLE 54. CANDY TRAY ASSEMBLY (PART 2 OF 2)

INDEX	PART NUMBER	DESCRIPTION	QTY.
1	1599013	HARNESS - 10 MOTOR TRAY (159)	1
	1599015	HARNESS - 4 MOTOR (160, 468, 490, 493)	1
2	1577035	MOTOR & PCB ASSEMBLY (159)	10
		MOTOR & PCB ASSEMBLY (160)	8
3	3502907	BUSHING	1
4	1477113	COUPLING - SPIRAL (159)	10
		COUPLING - SPIRAL (160)	8
5	-	SPIRALS (SEE TABLE 58 A FOR DETAILS)	-

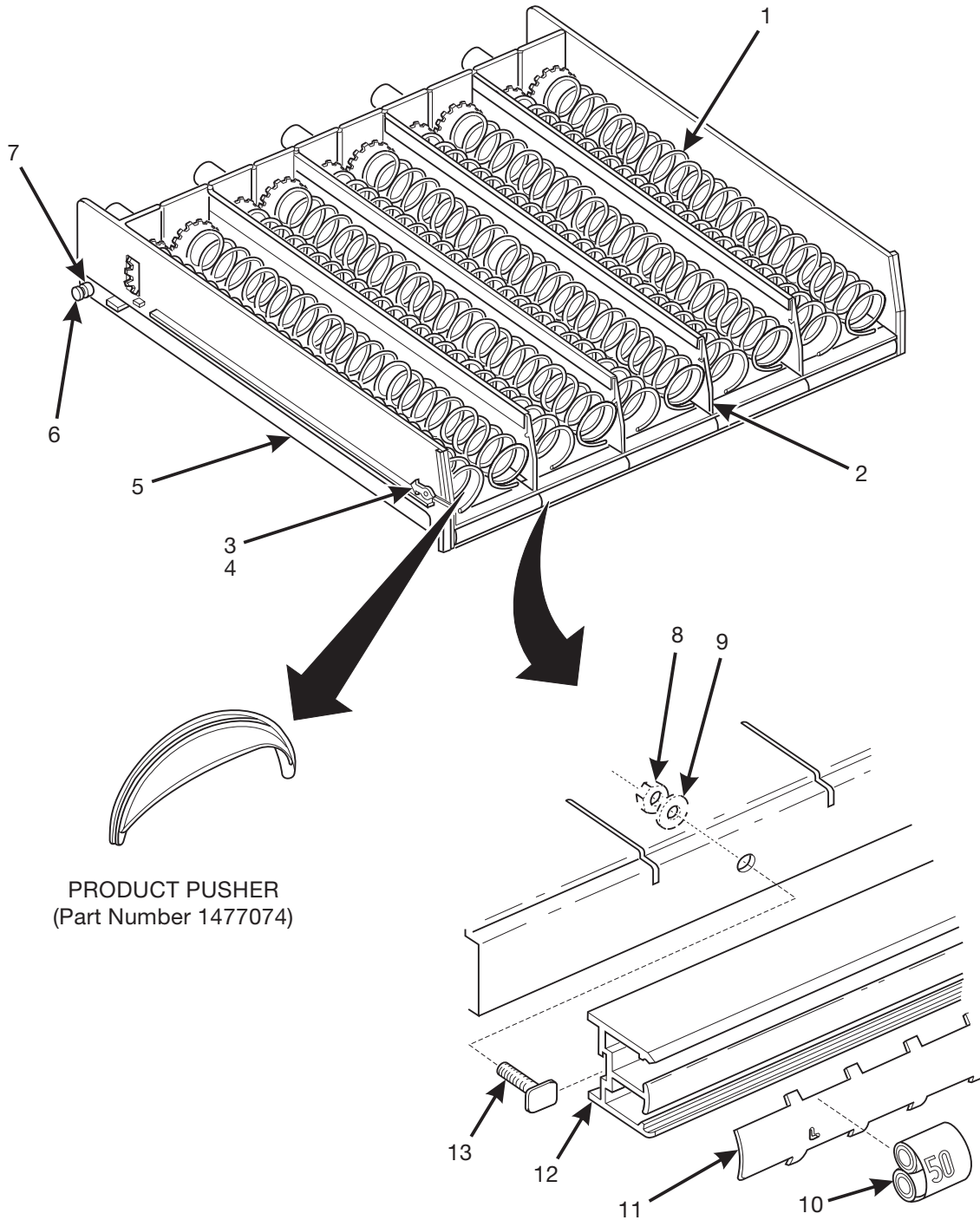

159P0034

Figure 28. Snack Tray Assembly (Part 1 of 2)

Snackvendor Models 159 - 160 Parts Manual

TABLE 55. SNACK TRAY ASSEMBLY (PART 1 OF 2)

INDEX	PART NUMBER	DESCRIPTION	QTY.
-	1597001	TRAY ASSEMBLY - 5 SNACK (159) (SHOWN)	1
	1607001	TRAY ASSEMBLY - 4 SNACK (160) (NOT SHOWN)	
1	-	SPIRAL (SEE TABLE 58 A FOR DETAILS)	-
2	1477175	WALL - TRAY (159)	4
		WALL - TRAY (160)	3
3	1477017	LATCH	2
4	5201267	PUSH ON RETAINER - .312	2
5	1577040	TRAY - 5 & 10 DIVISION (159)	1
	1587003	TRAY - 4 & 8 DIVISION (160)	
6	1477097	AXLE - TRAY ROLLER	2
7	1477148	ROLLER - TRAY	2
		NUT #8-32 SELF-LOCKING (159)	3
8	9900030	NUT #8-32 SELF-LOCKING (160)	2
		WASHER - HOPPER RELEASE (159)	3
9	5560113	WASHER - HOPPER RELEASE (160)	2
		ROLL - PRICE - CENTS (159)	5
10	1477014	ROLL - PRICE - CENTS (160)	4
		HOLDER - PRICE & SELECTION (159)	1
11	1477157	HOLDER - PRICE & SELECTION (160)	
	1487016	RAIL - PRICE & SELECTION (159)	1
12	1477134	RAIL - PRICE & SELECTION (160)	
	1487009	TEE BOLT - TRIM (159)	3
13	2222031	TEE BOLT - TRIM (160)	2

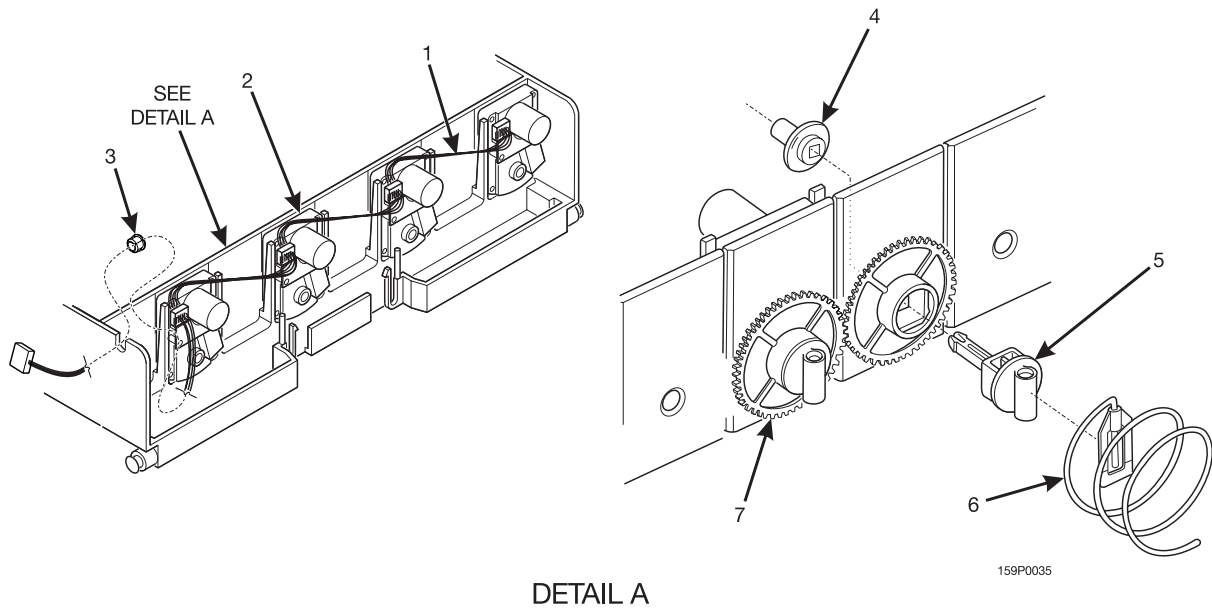

Figure 29. Snack Tray Assembly (Part 2 of 2)

Snackvendor Models 159 - 160 Parts Manual

TABLE 56. SNACK TRAY ASSEMBLY (PART 2 OF 2)

INDEX	PART NUMBER	DESCRIPTION	QTY.
1	1599012	HARNESS - 5 MOTOR TRAY (159)	1
	1599014	HARNESS - 4 MOTOR TRAY (160)	
2	1577035	MOTOR & PCB ASSEMBLY (159)	5
		MOTOR & PCB ASSEMBLY (160)	4
3	3502097	BUSHING	1
4	1477022	BEARING - COUPLER (159)	5
		BEARING - COUPLER (160)	4
5	1477113	COUPLING - SPIRAL (159)	10
		COUPLING - SPIRAL (160)	8
6	-	SPIRALS (SEE FIGURE 58 A FOR DETAILS)	-
7	1477020	GEAR - TRAY (159)	10
		GEAR - TRAY (160)	8

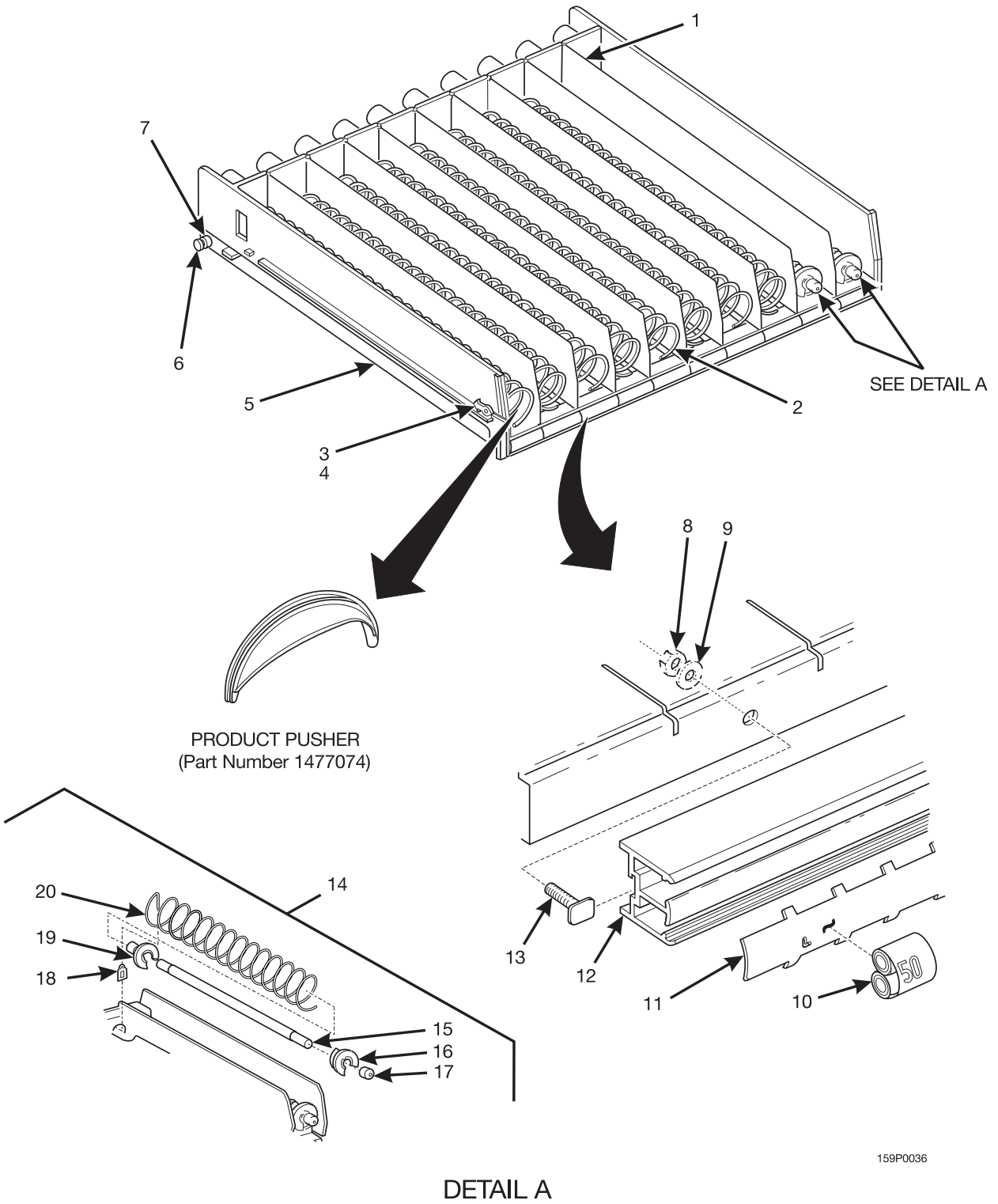
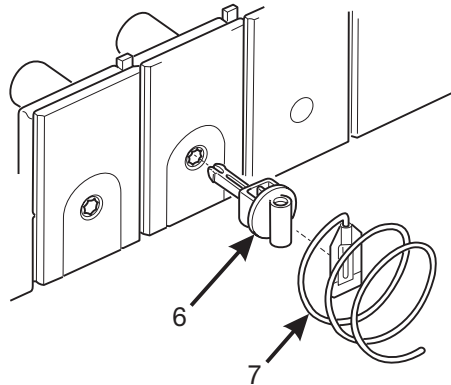
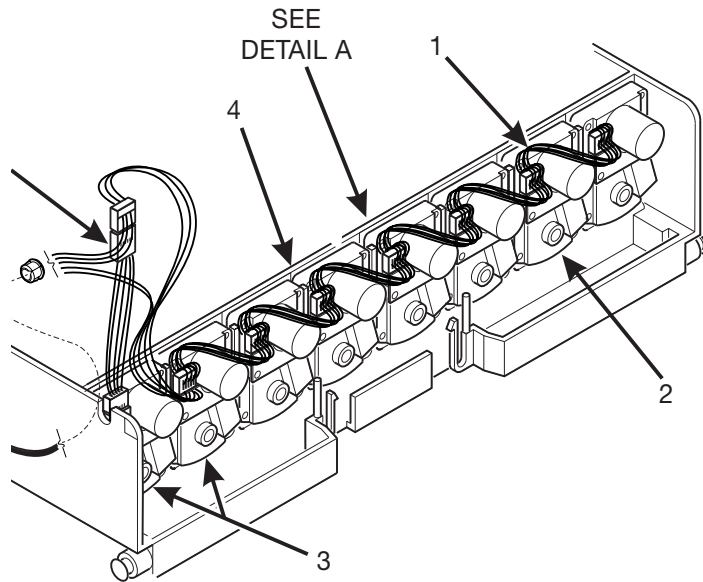

Figure 30. Gum and Mint Tray Assembly (Part 1 of 2)

Snackvendor Models 159 - 160 Parts Manual

TABLE 57. GUM AND MINT TRAY ASSEMBLY (PART 1 OF 2)

INDEX	PART NUMBER	DESCRIPTION	QTY.
-	1597003	TRAY ASSEMBLY - 8 CANDY - 2 GUM (159) (SHOWN)	1
	1607003	TRAY ASSEMBLY - 6 CANDY - 2 GUM (160) (NOT SHOWN)	
1	1477175	WALL - TRAY (159)	9
		WALL - TRAY (160)	7
2	-	SPIRAL (SEE TABLE 58 A FOR DETAILS)	-
3	1477017	LATCH	2
4	5201267	PUSH ON RETAINER - .312	2
5	1577040	TRAY - 5 & 10 DIVISION (159)	1
	1587003	TRAY - 4 & 8 DIVISION (160)	1
6	1477097	AXLE - TRAY ROLLER	2
7	1477148	ROLLER - TRAY	2
8	9900030	NUT #8-32 SELF-LOCKING (159)	3
		NUT #8-32 SELF-LOCKING (160)	2
9	5560113	WASHER - HOPPER RELEASE (159)	3
		WASHER - HOPPER RELEASE (160)	2
10	1477014	ROLL - PRICE - CENTS (159)	10
		ROLL - PRICE - CENTS (160)	8
11	1477157	HOLDER - PRICE & SELECTION (159)	1
	1487016	HOLDER - PRICE & SELECTION (160)	
12	1477134	RAIL - PRICE & SELECTION (159)	1
	1487009	RAIL - PRICE & SELECTION (160)	
13	2222031	TEE BOLT - TRIM (159)	3
		TEE BOLT - TRIM (160)	2
14	1467127	SPIRAL ASSEMBLY - DUAL GUM & MINT (INCLUDES INDEX NUMBERS 15 - 20)	2
15	1467131	SPIRAL INSERT ASSEMBLY	1
16	1467129	DISC - SPIRAL INSERT	1
17	1467136	CAP - SPIRAL INSERT	2
18	1467130	DISC - SPIRAL INSERT	1
19	1467137	RETAINER - SPIRAL - ORANGE	1
20	1467128	SPIRAL - 2.65 DIAMETER - DUAL GUM & MINT	1



DETAIL A

159P0038

Figure 31. Gum and Mint Tray Assembly (Part 2 of 2)

Snackvendor Models 159 - 160 Parts Manual

TABLE 58. GUM AND MINT TRAY ASSEMBLY (PART 2 OF 2)

INDEX	PART NUMBER	DESCRIPTION	QTY.
1	1599013	HARNESS - 10 MOTOR TRAY	1
2	1577035	MOTOR & PCB ASSEMBLY (159)	8
		MOTOR & PCB ASSEMBLY (160)	6
3	1477114	MOTOR & PCB ASSEMBLY (159, 160)	2
4	3502097	BUSHING	1
5	1477156	JUMPER ASSEMBLY - MOTOR REVERSING	1
6	1477113	COUPLING - SPIRAL (159)	10
		COUPLING - SPIRAL (160)	8
7	-	SPIRALS (SEE FIGURE 58 A FOR DETAILS)	-

TABLE 58 A. SPIRAL OPTIONS

			PART NUMBERS			
			LEFT HAND		RIGHT HAND	
Spiral Count	Retainer Color	Retainer	Assembly	Spiral	Assembly	Spiral
5	-	-	-	1477178	-	1477179
6	PURPLE	1477107	1477103	1477102	1477105	1477104
9	GRAY	1477155	1477149	1477150	1477152	1477153
11	BLUE	1457061	1477023	1477024	1477026	1477027
13	YELLOW	1457062	1477029	1477030	1477032	1477033
15	RED	1457063	1477035	1477063	1477038	1477039
17	BROWN	1477106	1477101	1477100	1477099	1477098
20	WHITE	1457064	1477041	1477042	1477044	1477045
25	GREEN	1457065	1477047	1477048	1477050	1477051
30	BLACK	1477073	1477053	1477054	1477056	1477057
38	ORANGE	1467137	1477059	1477060	1477062	1477063

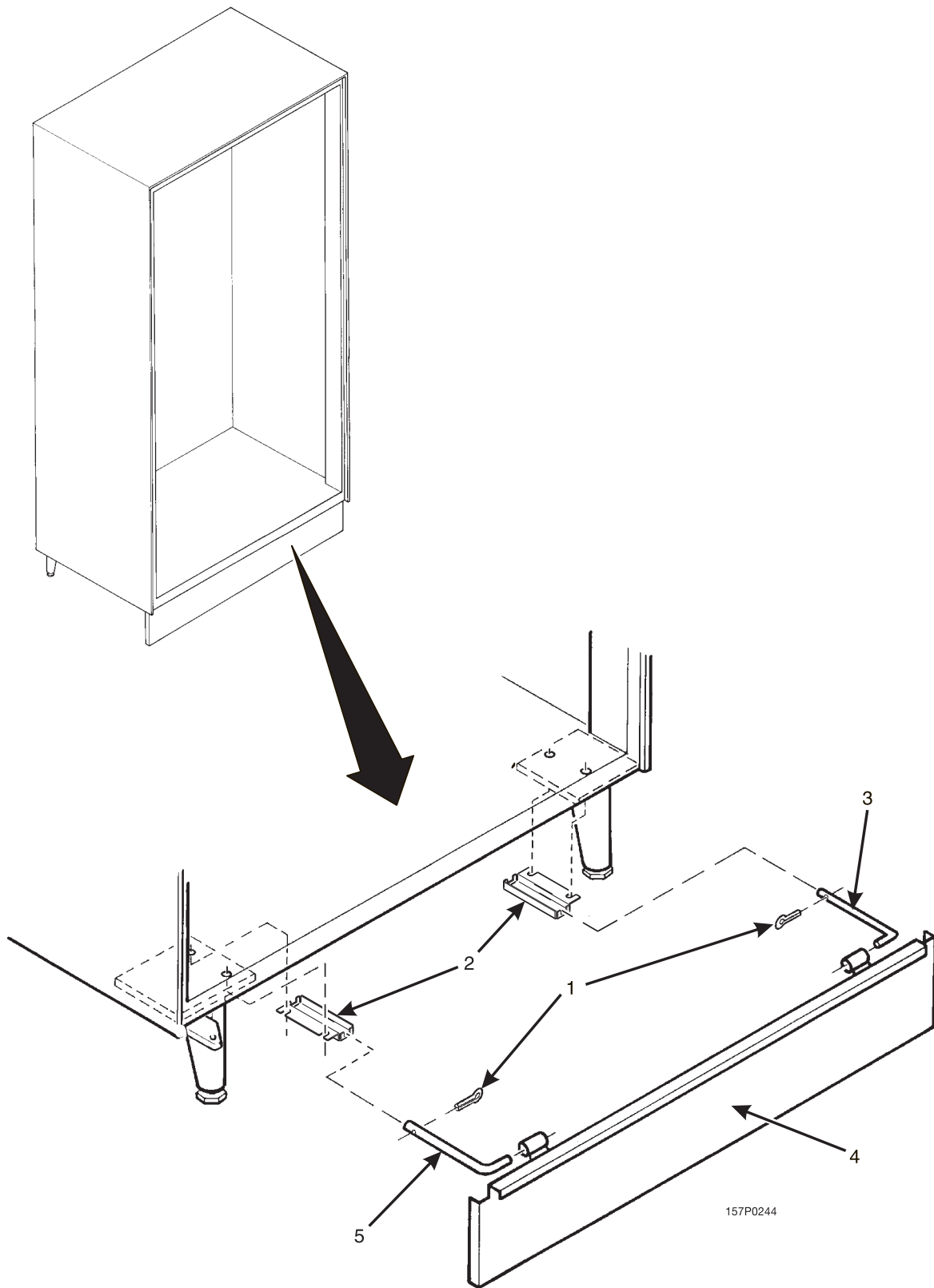

Figure 32. Base Plate Assembly

Snackvender Models 159 - 160 Parts Manual

TABLE 59. BASE PLATE ASSEMBLY

INDEX	PART NUMBER	DESCRIPTION	QTY.
1	9900098	COTTER PIN, 3/32	2
2	6231087	BRACKET - BASE PLATE	2
3	1411194	SLIDE - BASE PLATE - RIGHT HAND	1
4	1581023	BASE PLATE ASSEMBLY (160)	1
	2271408	BASE PLATE ASSEMBLY (159)	
5	1411195	SLIDE - BASE PLATE - LEFT HAND	1

The wiring harness illustrations that follow should be used along with the wire diagram for your merchandiser.

POWER PANEL TO EXHAUST FAN JUMPER



24VAC PCB & COIN POWER HARNESS



16 CONDUCTOR RIBBON CABLE

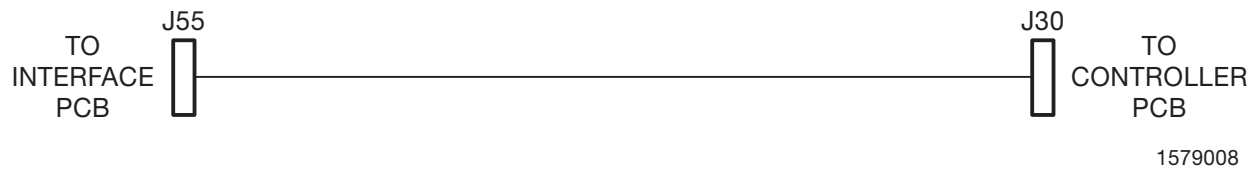

Figure 33. Wiring Harnesses (Part 1 of 10)

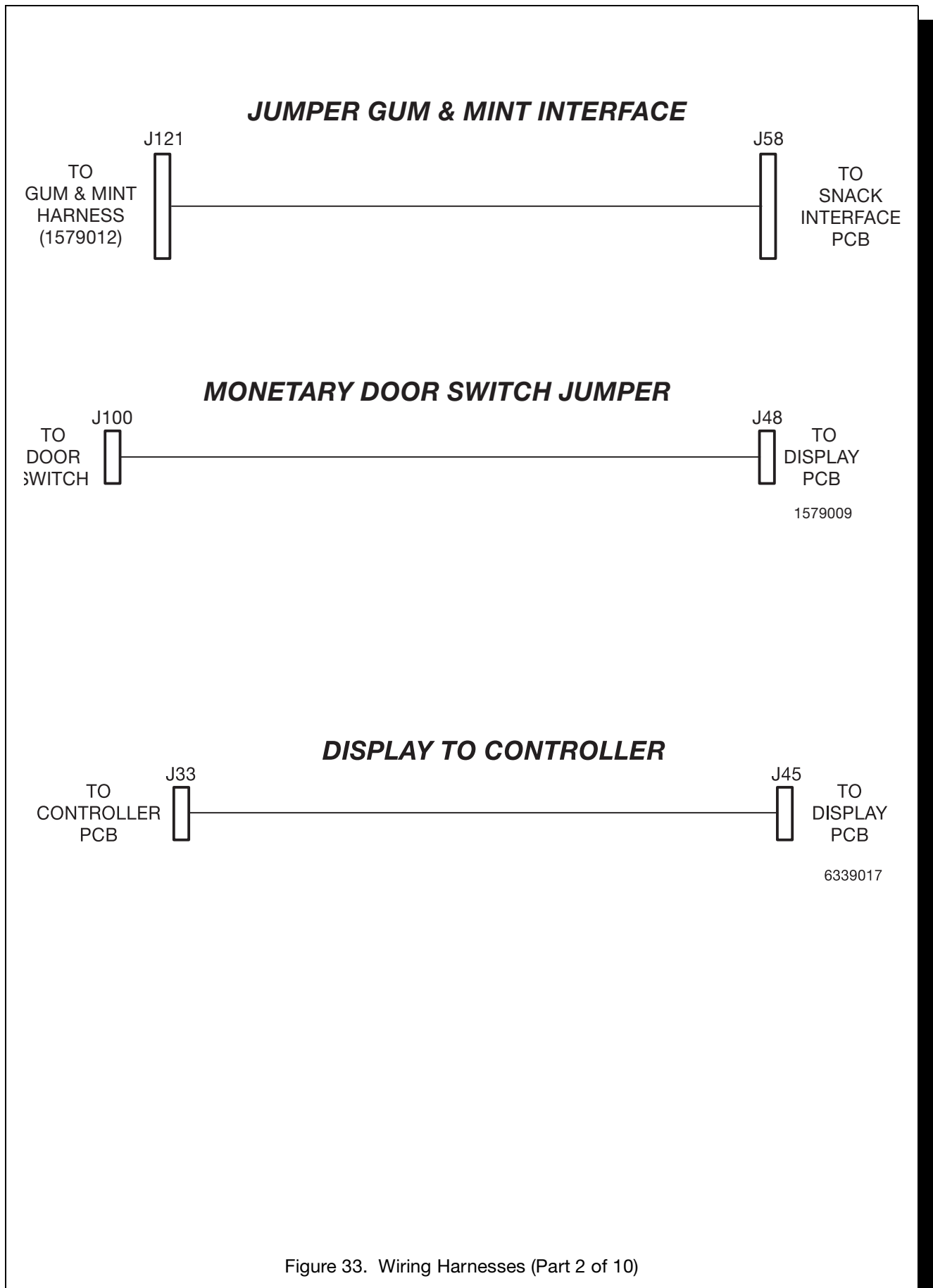

Figure 33. Wiring Harnesses (Part 2 of 10)

POWER PANEL TO FLUORESCENT LIGHT JUMPER



**1579025
FOREIGN NO INTERLOCK JUMPER**

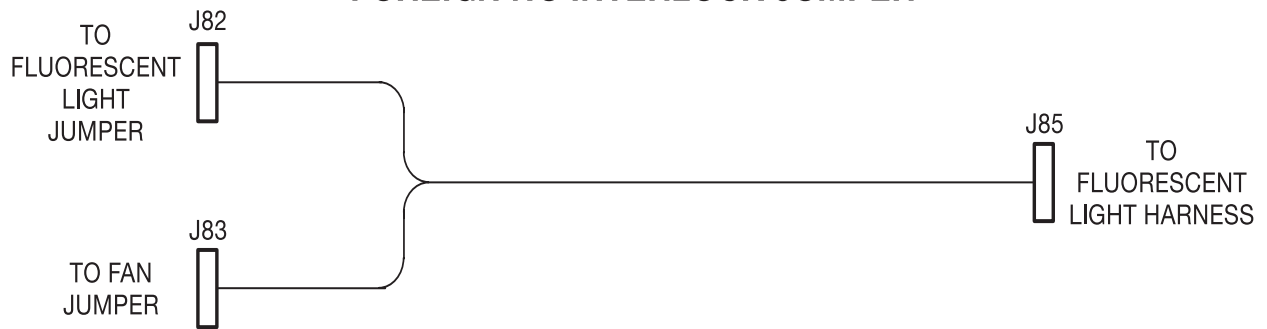

Figure 33. Wiring Harnesses (Part 3 of 10)

SMALL SNACK FLUORESCENT LIGHT HARNESS

DEX PRINTER INTERFACE HARNESS



Figure 33. Wiring Harnesses (Part 4 of 10)

EURO PLUG POWER CORD



**9985043
CORD SET POLARIZED-GROUNDED**

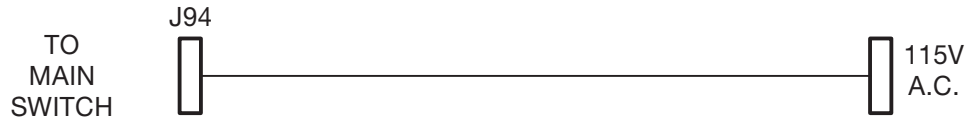

TABLE 60. LABELS USED WITH 9985043

PART NUMBER	DESCRIPTION
9989526	LABEL - WARNING - POWER CORD - ENGLISH
9989583	LABEL - WARNING - POWER CORD - SPANISH

Figure 33. Wiring Harnesses (Part 5 of 10)

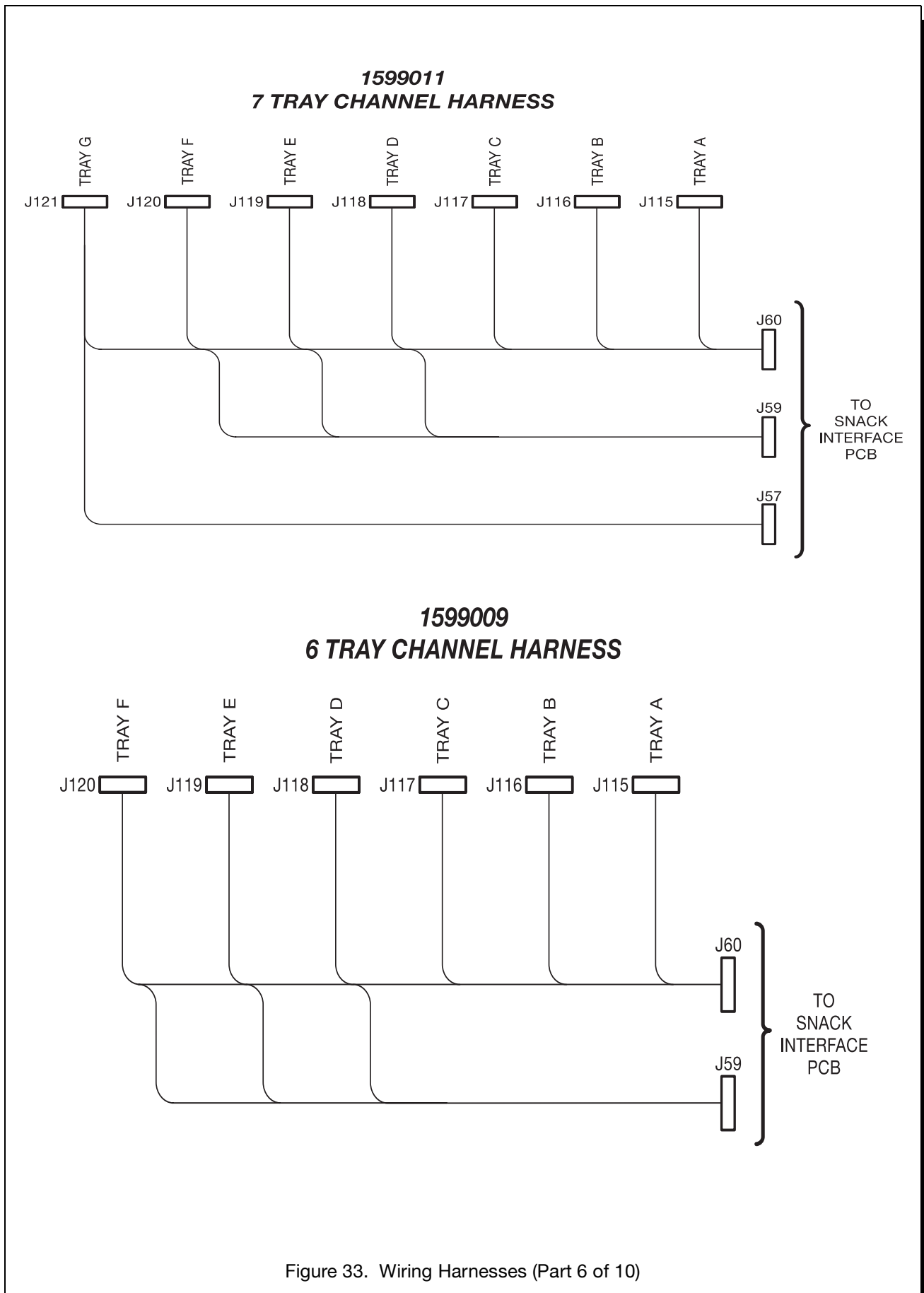
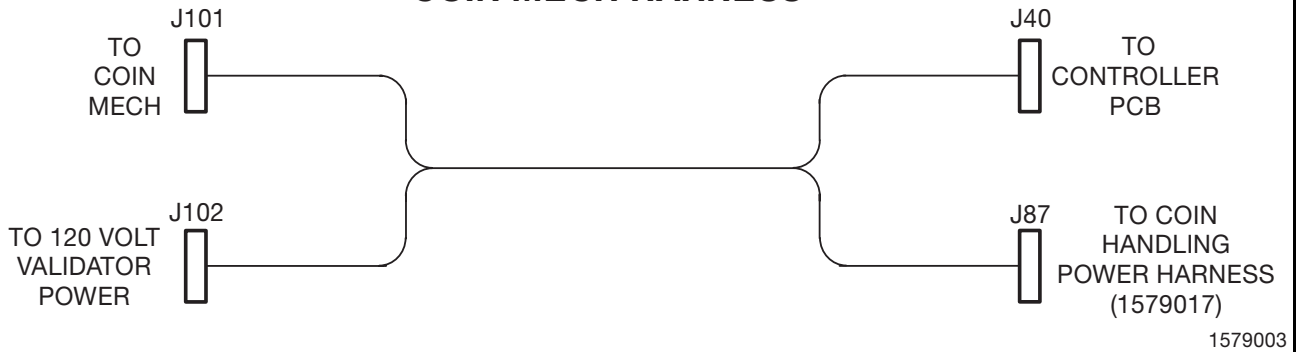

Figure 33. Wiring Harnesses (Part 6 of 10)

HARNESSES FOR COIN MECH OPTIONS

COIN MECH HARNESS



EXECUTIVE COIN MECH JUMPER



Figure 33. Wiring Harnesses (Part 7 of 10)

HARNESSES FOR MDB COIN OPTIONS

MDB HARNESS

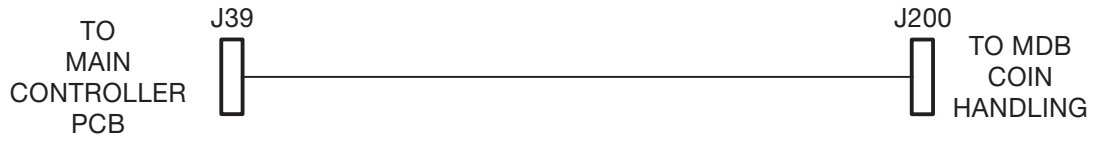

HARNESSES FOR SERIAL AND PULSE BILL VALIDATOR OPTIONS

24V VALIDATOR JUMPER



9989718

**HARNESS - SERIAL VALIDATORS
-24 VOLTS**

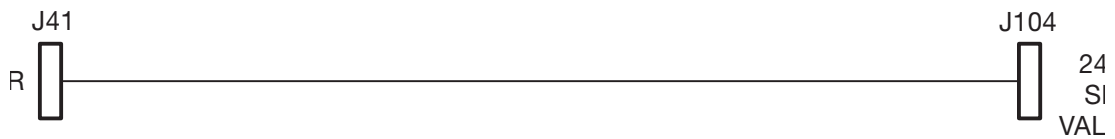

Figure 33. Wiring Harnesses (Part 8 of 10)

HARNESSES FOR SERIAL AND PULSE BILL VALIDATOR OPTIONS (CONTINUED)

SERIAL VALIDATOR HARNESS



MAKA PULSE VALIDATOR HARNESS



MARS PULSE VALIDATOR HARNESS

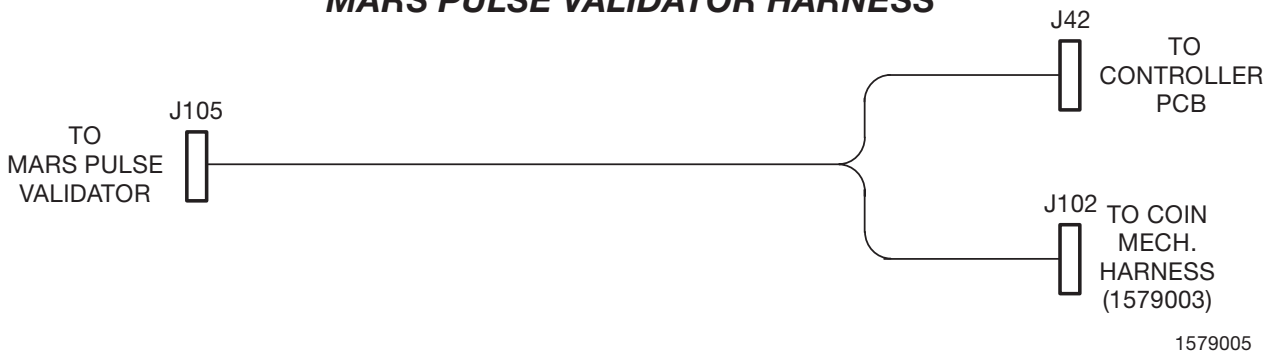

Figure 33. Wiring Harnesses (Part 9 of 10)

HARNESSES FOR MDB VALIDATOR OPTIONS

MDB FOR COINCO BA30SA HARNESS



MDB FOR CONLUX MKA 2000 HARNESS



ACCESSORIES

**1709017
TRAY EXTENSION HARNESS**

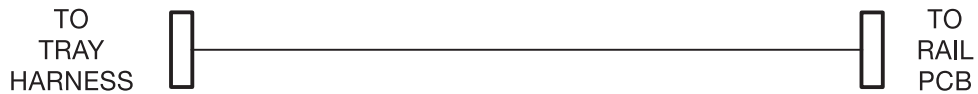
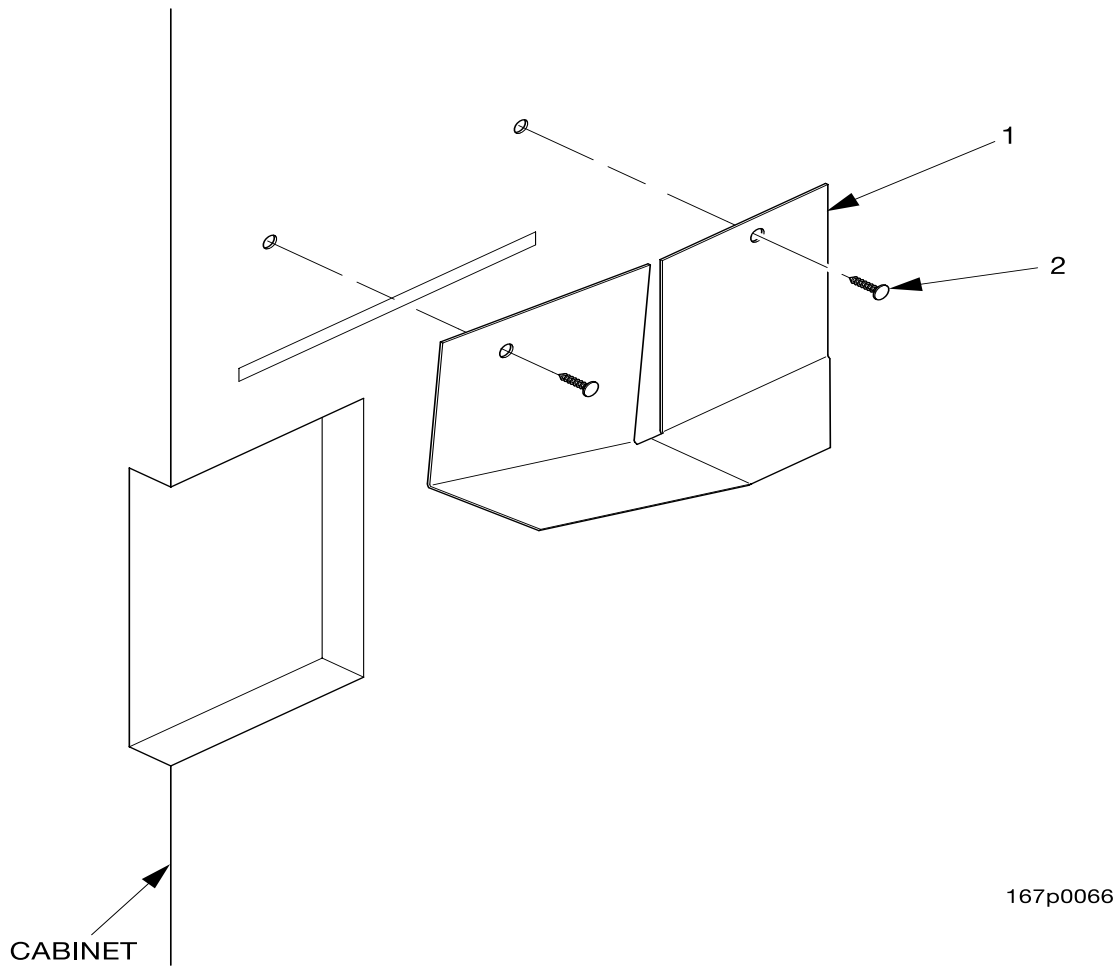

Figure 33. Wiring Harnesses (Part 10 of 10)

Snackvendor Models 159 - 160 Parts Manual

TABLE 32.

INDEX	PART NUMBER	DESCRIPTION	QUANTITY
1	1681058	DEFLECTOR - UPPER LHS - PLASTIC	1
2	2342044	CLIP - CHRISTMAS TREE	2



Snackvendor Models 159 - 160 Parts Manual

TABLE 33.

INDEX	PART NUMBER	DESCRIPTION	QUANTITY
1	7971014	OVERLAY NON - REFL UPPER DEFLECTOR	1
1	7971015	OVERLAY NON - REFL LOWER PILFER DR	1
1	'7841017	OVERLAY NON - REFLECTIVE - 8 SELECT CAN	

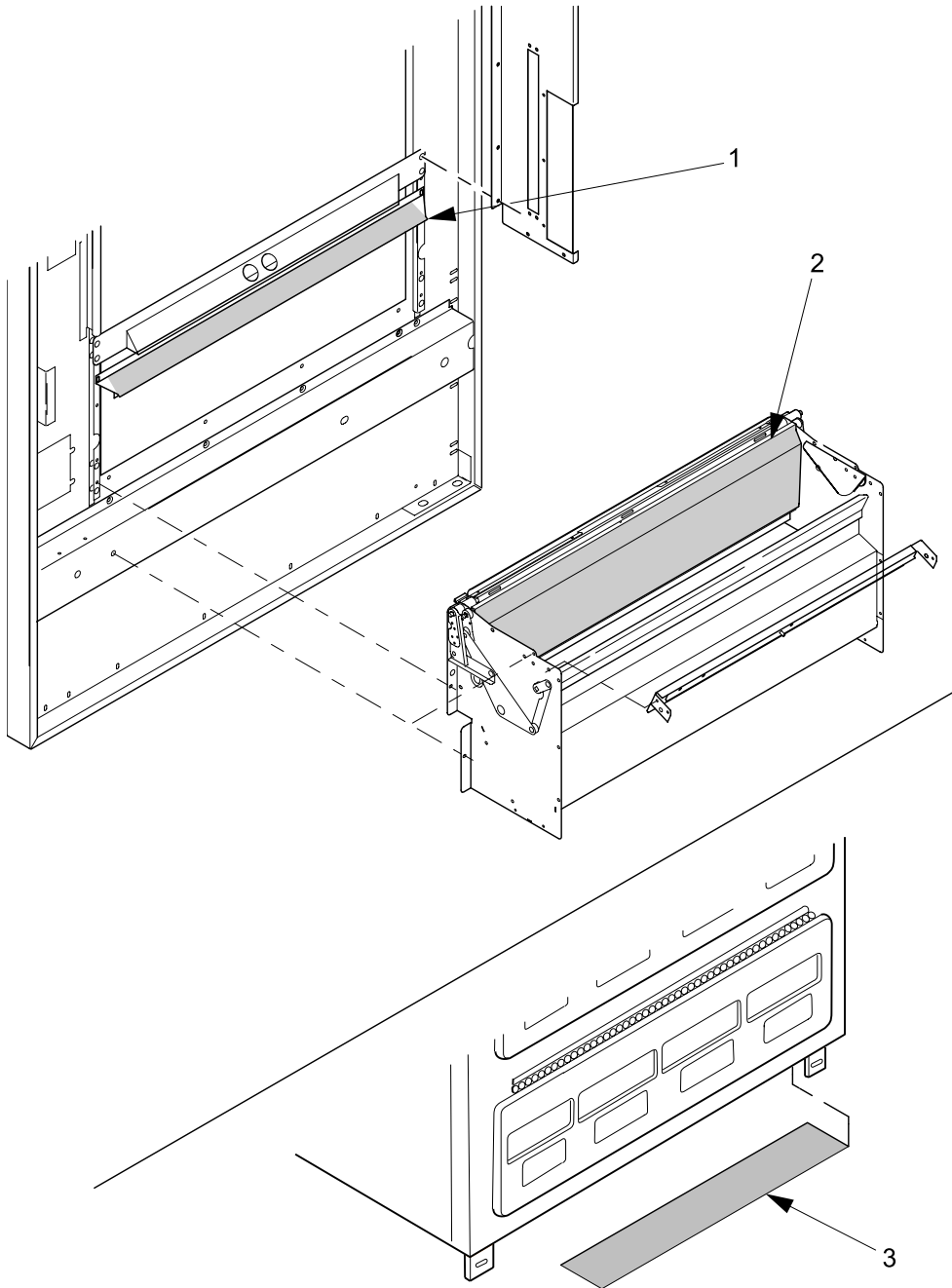

167p0063

Snackvendor Models 159 - 160 Parts Manual

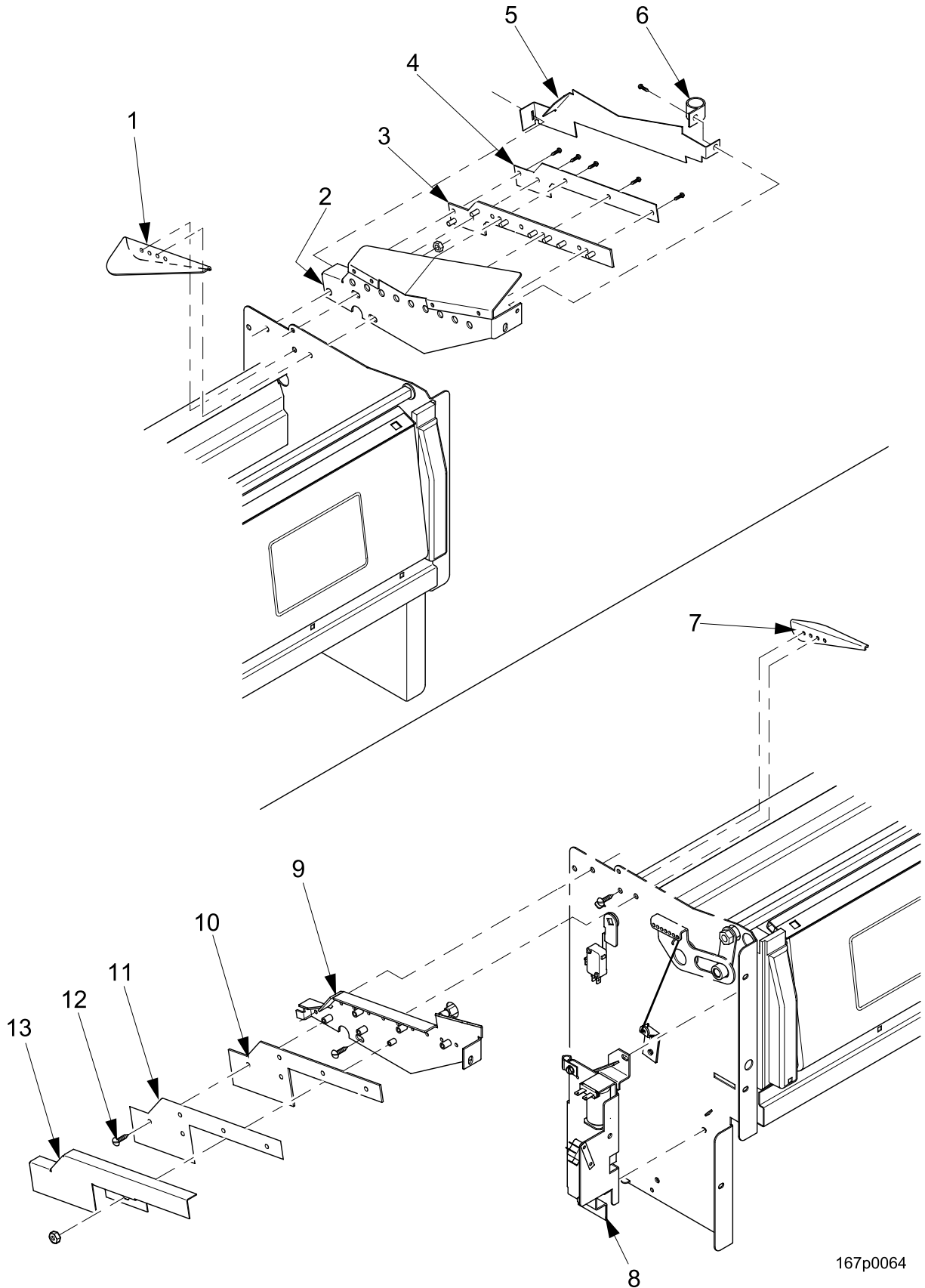

167p0064

Snackvendor Models 159 - 160 Parts Manual

TABLE 34.

INDEX	PART NUMBER	DESCRIPTION	QUANTITY
1	1672044	COVER - PCB - RH	1
2	1672051	PAPER BACKING - RH. PCB	1
3	1726001	PCB ASSEMBLY - PRODUCT DET. - EMITTER - GPL	1
4	1672032	SENSOR BRACKET ASSEMBLY - RT	1
5	1672038	DEFLECTOR - INNER - RH - FLT "T" BLK	1
6	1452139	RETAINER HARNESS	--

TABLE 35.

INDEX	PART NUMBER	DESCRIPTION	QUANTITY
1	1672029	SENSOR BRACKET - ASSEMBLY - LT	1
2	1726000	PCB ASSEMBLY - PRODUCT DET. EMITTER - GPL	1
3	1672050	PAPER BACKING - LT. PCB	1
4	5262216	SCREW - #6 - 32 X 1/4" PPHD M SCR	--
5	1672043	COVER - PCB LH	1
6	7970004	KIT - LOCK SOLENOID - FOOD MODULE	1
7	1672039	DEFLECTOR - INNER - LH FLT "T" BLK	1

Snackvendor Models 159 - 160 Parts Manual

TABLE 36.

INDEX	PART NUMBER	DESCRIPTION	QUANTITY
1	1672032	SENSOR BRACKET - ASSEMBLY - RT	1
2	1726000	PCB ASSEMBLY - PRODUCT DET. RECEIVER - GPL	1
3	1672051	PAPER BACKING - RT. PCB	1
4	5262216	SCREW #6 - 32 X 1/4" PPHD M SCR.	--
5	7852000	COVER - PCB - RH (COFFEE MODULE ONLY)	1
6	7852001	DEFLECTOR - RT - PLASTIC (COFFEE MODULE ONLY)	1

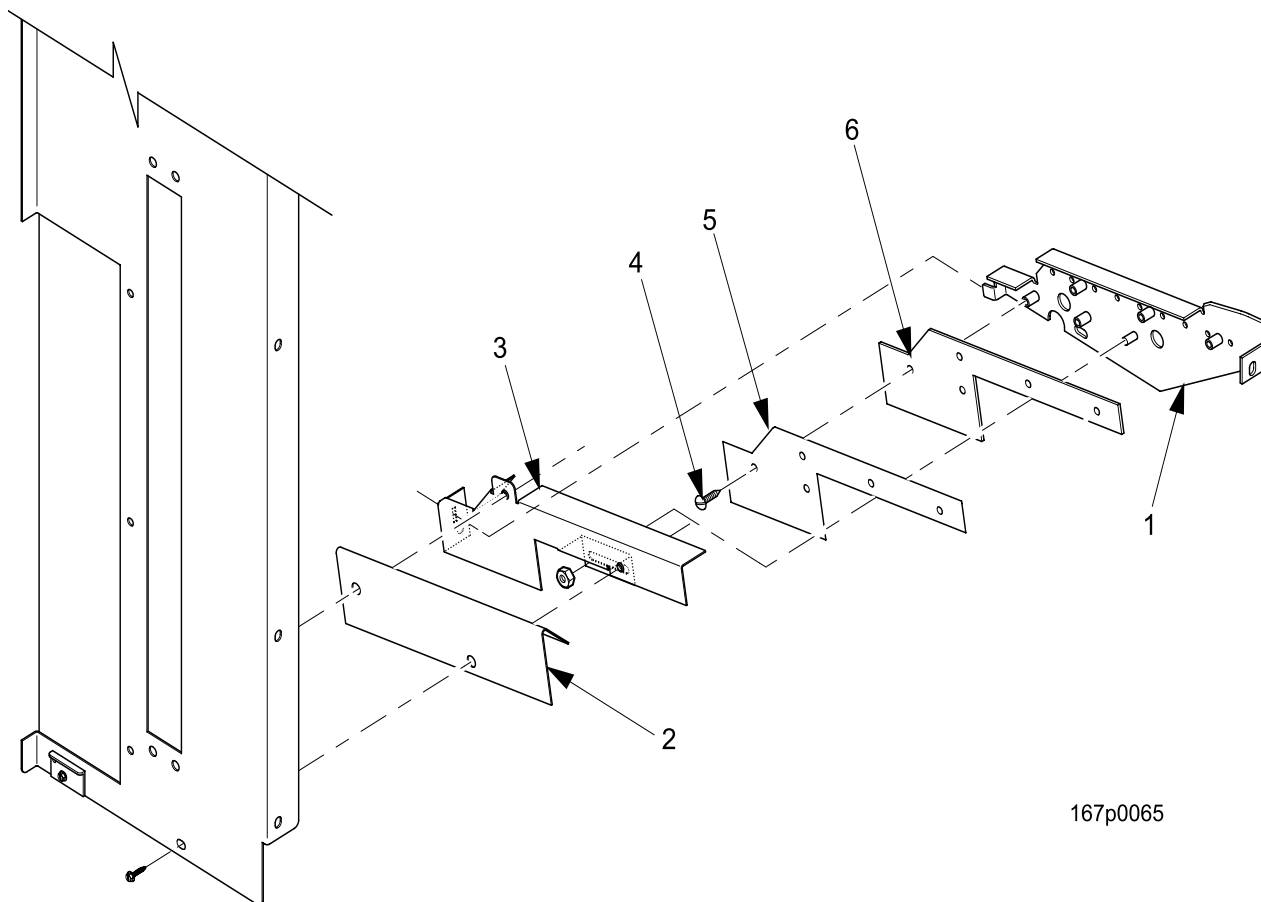
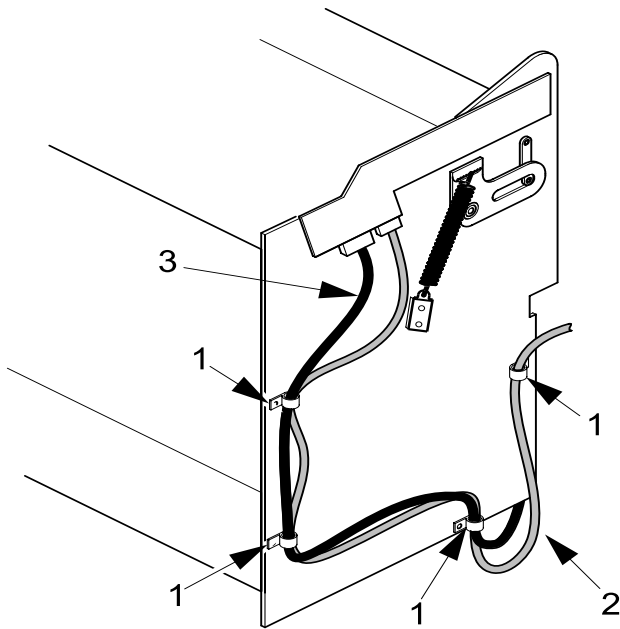
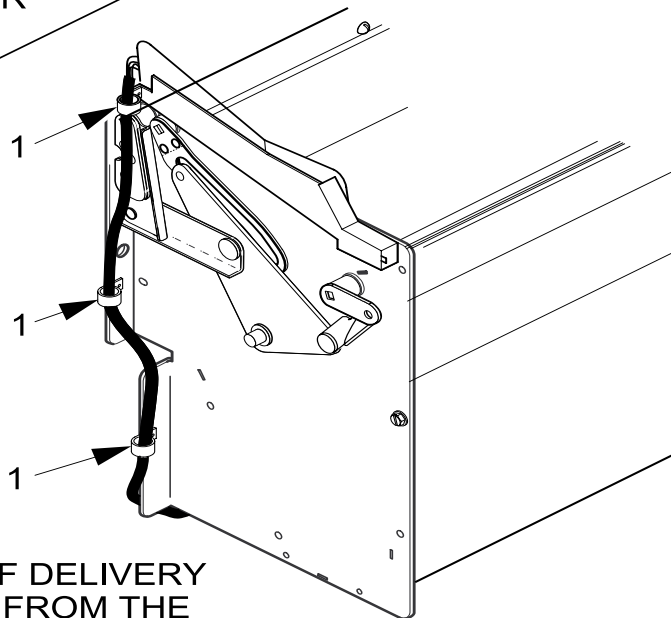

TABLE 37.

INDEX	PART NUMBER	DESCRIPTION	QUANTITY
1	4732024	RETAINER - HARNESS	--
2	1679012	HARNESS - MAIN CONTROLLER TO SENSOR	1
3	1679013	HARNESS - EMITTER TO DETECTOR	1



HINGE SIDE OF DELIVERY PAN
VIEWED FROM THE INTERIOR
OF DOOR



LOCK SIDE OF DELIVERY PAN
VIEWED FROM THE
INTERIOR OF DOOR

167p0067

Supplement to 1590050: posi-vend™ Operation

This document will explain the operation and usage of the posi-vend™ guaranteed product delivery system for GPL spiral vendors. A series of “electric eyes” is mounted on the delivery pan. When a product drops into the delivery pan, it breaks the beam of the “electric eye”, telling the controller that a product has been delivered. If a selection is made and the spiral makes one complete revolution without delivering a product, the controller will command the spiral to turn until a product is delivered, up to three times. After that, the customer’s money is refunded.

Your posi-vend™ guaranteed product delivery system is completely factory set, with no user programmable functions. However, some additional diagnostic messages may appear if there is a malfunction in the system.

If the posi-vend™ PCB is not working properly, or a main delivery area is blocked, or the posi-vend™ PCB is not detected by the controller, all posi-vend™ functions are ignored and the merchandiser reverts to normal home switch operation.

Note:

A blocked gum & mint posi-vend™ sensor does not affect the status of posi-vend™ for snack tray selections.

A blocked gum & mint posi-vend™ sensor will cause the merchandiser to revert to home switch operation for food module selections.

Motor Operation Under posi-vend™

If posi-vend™ is working the motor will stop at the home switch position if the spiral has gone less than one revolution without passing home when the product is detected.

If posi-vend™ is working the motor will stop immediately when a product is detected provided the motor has gone past home at least one time. The motor will temporarily pause at each home switch position before continuing. (See can and gum&mint exceptions.)

If posi-vend™ is working but product delivery is not detected, the motor will stop the third time it enters the home switch position. The vend fails and credit is returned.

Gum & Mint vends are not complete until the product is detected then leaves the posi-vend™ sensor path. This protects against products jamming in the gum & mint delivery area.

Can selections will attempt only one vend before failing if product is not detected.

Any selection that fails under posi-vend™ will be put out-of-service and will generate an *EMPTY* diagnostic as described below. These out-of-service conditions apply even if posi-vend™ subsequently becomes non-operational. These out-of-service conditions are automatically reset at time-of-service based upon the closure of the main door.

If ten selections go *EMPTY* posi-vend™ will enter its anti-jackpot mode and all motors revert to home switch operation until the main door is opened and closed.

posi-vend™ Diagnostics

The following diagnostics may appear in the diagnostic list:

POSI.VD X if posi-vend™ detects a blockage of LED "x" counted from the front of the machine. "x" = "H" for the gum & mint sensor. Press **H** to see the realtime calibration values

POSI.VD CAL if posi-vend™ detects a calibration error. Press **H** to see the realtime calibration values. The display will show the real-time calibration values for each of the 10 posi-vend™ zones. These are generally grouped in pairs corresponding to the emitter under test. The calibration determines the minimum amount of intensity from the posi-vend™ infrared emitters that is needed for detection. A safety margin of 3) is added and is displayed. Interpret "A" - "F" as the numbers "10" - "15".

1. A value of "0" indicates the detector is shorted and is a fatal error;
2. A value of "1" indicates the detector cannot see the emitter within the allowable calibration values;
3. Values "2" through "9" are normal;
4. Values above "9" may indicate dirty or misaligned sensors.
5. Values that change by more than a magnitude of 2 may indicate mechanical problems with the posi-vend™ alignment or dirty sensors.

EMPTY AA is shown when posi-vend™ did not detect product delivery from selection "aa". This diagnostic will be cleared when the main door closes. Those selections will be returned to service. This data is an indication of the number of posi-vend™ failures which returned the customer's credit.

POSI.VD OFF FOR ANTI.JP is shown if 10 selections go *EMPTY* since the last main door closure. posi-vend™ is disabled and operation reverts to home switches until the main door closes.