

GLASSFRONT MERCHANDISER (IIIA SERIES)

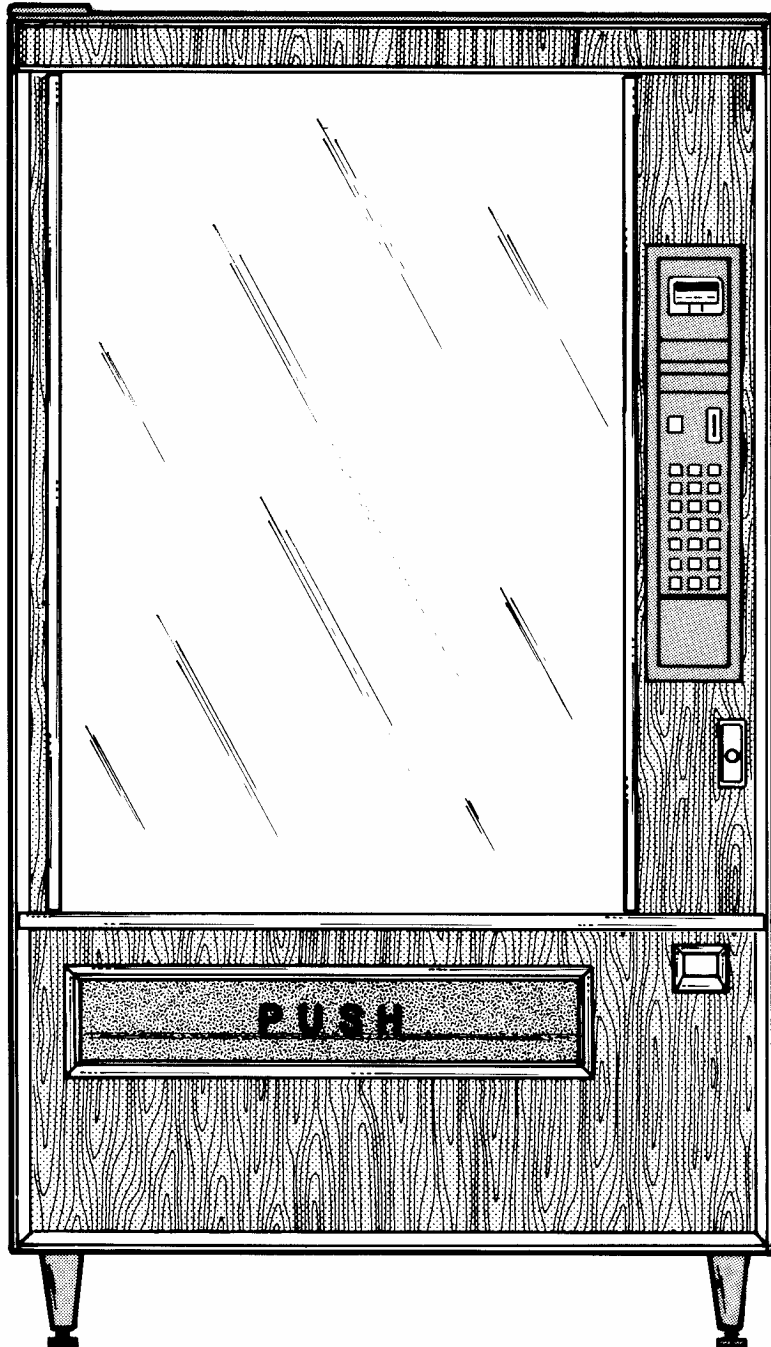

SERVICE MANUAL

P/N 4202139

TABLE OF CONTENTS

INTRODUCTION	1
SPECIFICATIONS	1
UNPACKING	2
INSTALLATION	3-6
LOOSE PARTS	3
GROUNDING & ELECTRICAL	4
LOADING (candy & snack)	4-5
LOADING (gum & mint)	5-6
CONFIGURATION	7-10
CHANGING MACHINE CONFIGURATION	7
CHANGING TRAY SPACING	7
CONVERTING TRAY CONFIGURATION	8
PRODUCT SPACERS	8
PRODUCT PUSHERS	8
PLASTIC TRAY CONVERSION	9-10
CONTROLLER FUNCTIONS	11-30
SALES MODE	11
DISCOUNT AVAILABLE NOW MESSAGE	11
POINT OF SALES MESSAGE	11
EXACT CHANGE ONLY MESSAGE	11
SERVICE MODE	12-23
Diagnostics	13
Point of Sales Message Mode	14
Price Setting Instructions	15
Copy Price Mode	16
Verifying Vend Prices	16
Coin Dispense Mode	17
Motor Count Mode	17
Test Vend Mode	18-20
Test vend single selection	18
Test vend complete row	19
Test vend complete machine	20
Vend Options Mode	21-23
Force vend option	21
Multi vend option	21-22
Promo vend option	22
Language option	23
Total vend / Total cash option	23
BATTERY BACKUP	24
BATTERY INSTALLATION	24
SET TIME MODE	25-30
Set Time of Day	25
Discount Programming	25-30
Set start/stop time	26-28
Set discount "on/off"	29
Set discount amount	29
Set discount row	29
Set select row option	30
INSTALLATION CHECKLIST	31
COMPONENTS	32-33
COIN MECHANISM REMOVAL	32
CONTROL BOARD REMOVAL	32
DISPLAY BOARD REMOVAL	33
TRANSFORMER REMOVAL	33
CONTROL PANEL REMOVAL	33
CARE & CLEANING	34
OPTIONAL ITEMS	35
TROUBLE SHOOTING	36-39
ELECTRICAL	36
VEND SEQUENCE	37
PRICE SETTING	38
COIN CHANGER	39
SCHEMATIC	40

INTRODUCTION

The contents of this manual will contain service and installation guidelines pertaining to the Glassfront Merchandiser (IIIA Series) along with various optional equipment and accessories that are offered within the product line.

The Glassfront Merchandiser is equipped with an electronic control system that can be programmed into the logic of the controller and used by the customer as needs arise for specific locations. Some of the features are "Discount Pricing", "Programmable Message Center", "Cash Accountability", "Total Vends", etc. Details of each of these features are defined within this manual.

The electronics within the controller allow all selections to be priced separately at various vend prices ranging from \$.05 to \$99.95 in five cent increments. All programming of the vend functions, pricing and features is done at the controller and changes and/or information can be retrieved without the need of any additional accessories or remote parts.

Electrical malfunctions are recorded by the controller and will be displayed to service personnel when the machine is placed in the "Service Mode".

All models have the "mix-and-match" designed trays that will allow the changing of selection configurations by adding or reducing the number of motors and augers. This allows the customer to change the vendable products on the spot to meet the specific needs of a location.

Basic tray configurations are offered from the factory, however, it is possible to re-arrange on location as the need arises as all models include the necessary wiring and controls for the full

capacity of all configurations.

The vending sequence of the Glassfront Merchandiser is a "first-in"/"first-out" procedure in each selection, eliminating the need for stock rotation to maintain fresh products in the vend area.

The trays are equipped with individual motors and augers for each selection and functional selections will continue to operate if other items become nonfunctional.

The height between each tray is adjustable in one (1) inch increments and a wide variety of augers are available, making it possible to vend a wide range of product sizes.

Each machine will be identified by a model number and a specific serial number. These identification numbers will appear on the serial number plate attached to the inside and rear of the vendor. Record these numbers for your records. All inquiries and correspondence pertaining to this vendor should reference the model and serial numbers.

It is recommended that this manual be read thoroughly to familiarize the service person with the functions of all components along with the features that are available. The initial set-up of a machine is a very important step of insuring that the equipment operates in a trouble-free manner. By following the instructions at the initial installation of the machine, service problems can be avoided and set-up time will be minimized.

Should you have any questions pertaining to information in this manual, replacement parts, or the operation of the vendor you should contact your local distributor or **Selectivend, Inc. / P.O. Box 488 / Waukeee, Iowa 50263-0488.**

SPECIFICATIONS

MODEL	SIZE	VOLTAGE USE	AMPS	HEIGHT	WIDTH	DEPTH	WEIGHT
3013A	3-WIDE	110 VOLTS	.6	72"	28 1/2"	34"	478 LBS
3014A	4-WIDE	110 VOLTS	.6	72"	34 1/4"	34"	500 LBS
3015A	5-WIDE	110 VOLTS	.6	72"	40 1/8"	34"	568 LBS
3023A	3-WIDE	220-240 VOLTS	.3	72"	28 1/2"	34"	478 LBS
3024A	4-WIDE	220-240 VOLTS	.3	72"	34 1/4"	34"	500 LBS
3025A	5-WIDE	220-240 VOLTS	.3	72"	40 1/8"	34"	568 LBS

UNPACKING

This machine has been thoroughly inspected before leaving the factory and the delivering carrier has accepted this vendor as their responsibility. Any damage or irregularities should be noted at the time of delivery and reported to the carrier. Request a written inspection report from the claims inspector to file any claim for damage. File the claim with the CARRIER **(NOT THE MANUFACTURER)** within 15 days after receipt of the machine.

Record the model number and serial number of the vendor for your records. These numbers can be found on the serial plate located on the rear of the cabinet. Refer to these numbers on all correspondence and inquiries pertaining to this vendor.

To minimize installation time and to avoid service problems due to improper installation, follow the instructions outlined in this manual.

Consult local, state and federal codes and regulations before installation of the vendor.

Remove the two (2) retaining blocks from the shipping pallet (see **Illustration #1A**). Slide the vendor forward on the shipping pallet until the side legs are clear of the pallet (see **Illustration #1B**). Tilt the machine sideways until the rear legs are clear of the pallet and remove the pallet (see **Illustration #1C**).

Position the vendor in its place of operation. Leave at least six (6) inches of space between the back of the machine and any wall or obstruction for proper air circulation. Level the vendor, making sure all levelers are touching the floor (see **Illustration #1D**). The vendor **MUST** be level for proper operation and acceptance of coins through the coin mechanism.

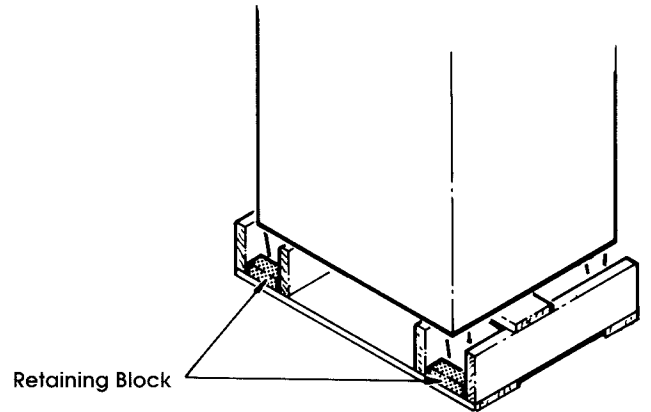

ILLUSTRATION #1A

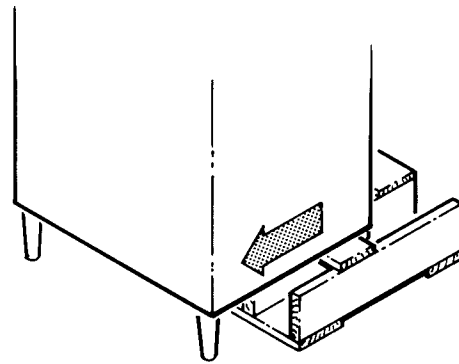

ILLUSTRATION #1B

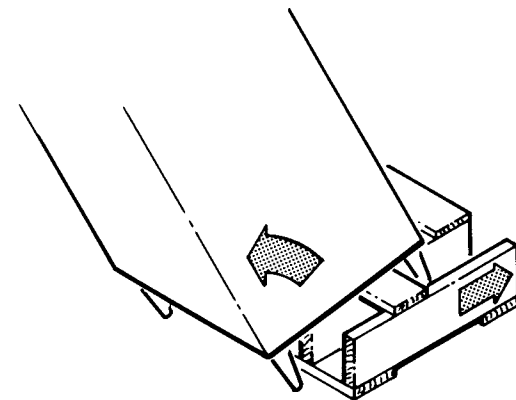

ILLUSTRATION #1C

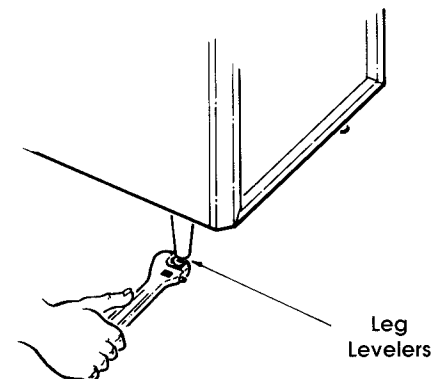

ILLUSTRATION #1D

INSTALLATION

LOOSE PARTS

Loose parts box and service packet will contain the following parts necessary for this installation.

SERVICE PACKAGE

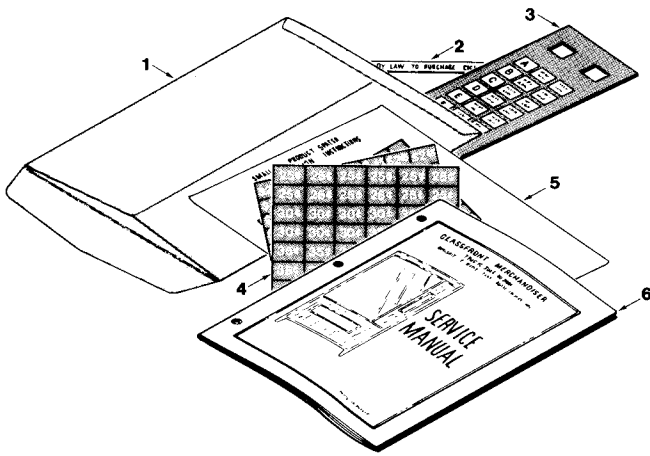

SMALL PARTS KIT

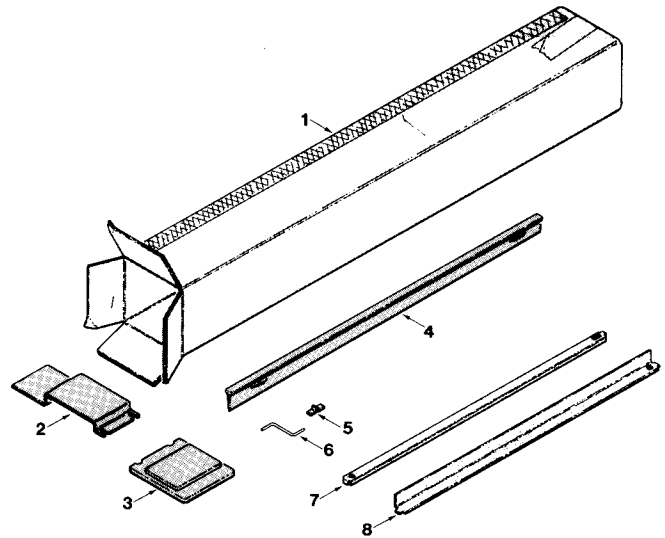

ITEM	PART NUMBER	3 WIDE	4 WIDE	5 WIDE	DESCRIPTION
SERVICE PACKAGE					
--	1211124	1	1	1	SERVICE PACKAGE
1	4020697	1	1	1	SERVICE MANUAL ENVELOPE
2	4020071	1	1	1	LABEL - MINORS FORBIDDEN
3	4200646	1	1	1	KEY PAD OVERLAY
4	4200052	2	2	2	PRICE LABELS .10 - 1.50
"	4200051	1	1	1	PRICE LABELS 1.50 - 3.15
"	▲8620154	1	1	1	PRICE LABELS .45 (G&M) ONLY
"	▲8620155	1	1	1	PRICE LABELS .50 - .75 (G&M) ONLY
5	4020834	1	1	1	INSTALLATION INSTRUCTIONS
6	4202139	1	1	1	SERVICE MANUAL
SMALL PARTS KIT					
--	1200160	1	1	1	SMALL PARTS KIT
1	4070170	1	1	1	BOX 4"x4"x30"
2	4003093-002	1	1	1	FILLER - RETAINER BRACKET
3	4025756	1	1	1	FILLER - VALIDATOR OPENING
4	8370660-5	4	4	4	SPACER
5	4200281	8	8	8	SPRING CLIP
6	8370998	8	8	8	SUPPORT SPACER
7	4003370	2	4	4	SPACER SMALL PRODUCT (G&M) ONLY
8	8383129-001	2	2	2	PARTITION (G&M) ONLY

▲ = OPTIONAL

INSTALLATION CONTINUED

GROUNDING & ELECTRICAL

For proper operation of any equipment utilizing electronic-controlled components, it is recommended that the equipment be placed on an isolated or dedicated circuit. The circuit should be a minimum 15 Amp, 115 Volt AC, 60 Hz, properly polarized and grounded. Shown in **Illustrations #2** and **#3** are two (2) properly grounded and polarized wall outlets. **Illustration #2** is a three (3) wire grounding type wall outlet. **Illustration #3** is a two (2) wire outlet with a three (3) plug adaptor in place. To verify that the receptacle is properly grounded and polarized, insert one probe of a volt/ohm meter (set to check AC line voltage) or a test light in the ground terminal (hole) and the other probe into the "hot" terminal of the outlet. You should read 115 VAC on the volt-meter or the test light should light.

NOTE: The "hot" side of the outlet should always be counter-clockwise from the grounded terminal, with the ground terminal at the bottom.

If you find that the receptacle is not grounded, or polarized, you should contact a licensed electrician to correctly polarize and/or ground the receptacle to ensure safe operation.

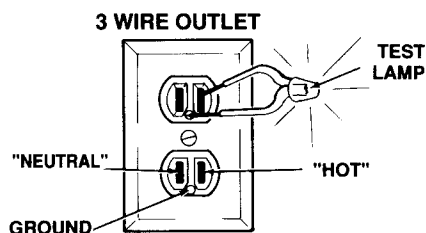

ILLUSTRATION #2

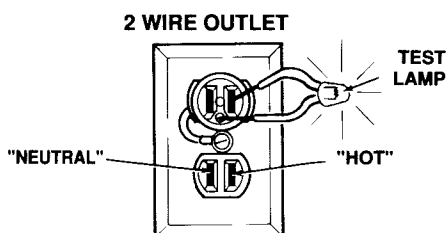

ILLUSTRATION #3

LOADING

"CANDY & SNACK" COMPARTMENTS

When loading, pull forward on the tray until it contacts the tray stop. The trays tilt downward for ease of loading.

When loading the products, load front to back making sure all items fit freely between the augers. Do not attempt to force oversize items into the spaces. All spaces forward **MUST** have a product in them; do not skip a space. The bottom of the item should be placed on the bottom of the compartment above the product augers, with the label facing the front of the machine easily identifiable to the customer. (See **Illustration #4**)

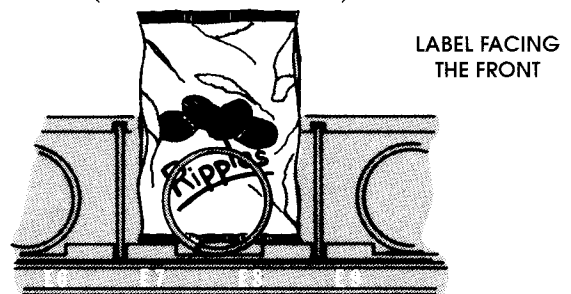

ILLUSTRATION #4

When finished with the loading of each tray, make sure the tray is returned to its proper standby position. All trays **MUST** be pushed to the rear portion of the cabinet area and properly seated in the "latched" position.

Each auger can be rotated in 20 degree increments, changing the auger position for a different "drop-off" point. Most items can be vended successfully when the auger end is positioned at 6 o'clock.

To change the auger end positions:

1. Remove the motor cover. (See **Illustration #5**).

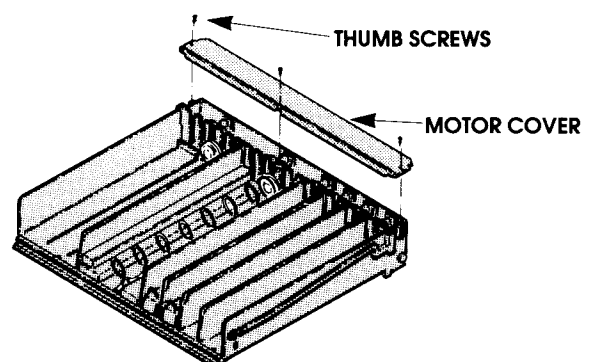

ILLUSTRATION #5

INSTALLATION CONTINUED

2. Raise up on the motor slightly and pull forward on the auger until it separates from the motor.
3. Rotate the auger to the desired position and re-insert the auger coupling into the motor.
4. Make sure the auger coupling is seated over the vertical rail on the tray. (See **Illustration #6**)

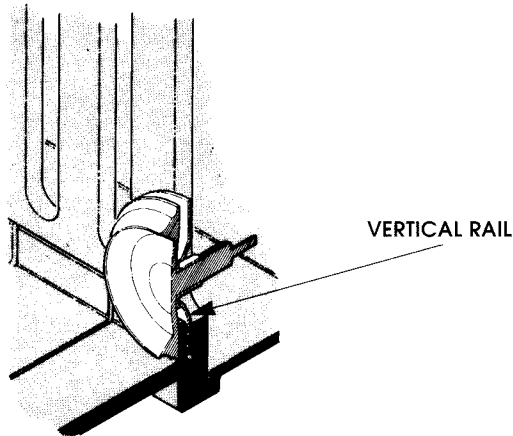

ILLUSTRATION #6

5. Replace the motor cover and tighten down the thumb screws.

The size of the item being vended **MUST** be larger than the diameter of the auger to vend properly. Undersized items could cause vend problems. Various "pitched" augers are available. If the product does not fit the auger properly it is recommended that a different pitched auger be used. The following is a list of augers that are available:

AUGER SIZES AVAILABLE				
AUGER TYPE	PRODUCT SIZE			AUGER PART NO.
	WIDTH	THICK	ITEMS	
CANDY	2-3/4	1-3/16	15	4200272-000
	2-3/4	15/16	18	4200272-001
	2-3/4	21/32	24	4200272-002
	2-3/4	1/2	30	4200272-003
	2-3/4	1-1/2	12	4200272-004
	2-3/4	2-1/32	9	4200272-005
	2-3/4	3-3/32	6	4200272-006
SNACK	5-1/2	1-13/16	10	4200272-007
	5-1/2	1-1/2	12	4200272-008
	5-1/2	1-3/16	15	4200272-009
	5-1/2	2-11/16	7	4200272-010
	5-1/2	2-5/8	8	4200272-011

LOADING "GUM & MINT" COMPARTMENT

To load the Gum & Mint Compartment:

1. Push up on the latch rod in the center portion of the Gum & Mint Compartment. (See **Illustration #7**)

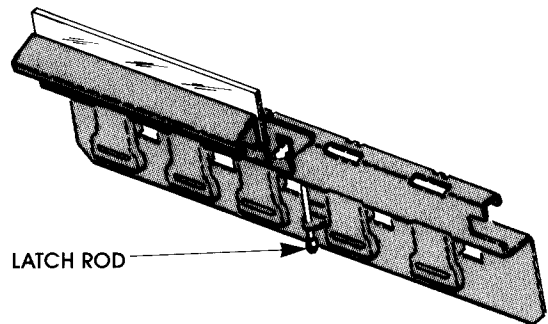

ILLUSTRATION #7

2. Pull forward on the tray until it contacts the tray stop.
3. Pull forward on the lid and raise to open it.
4. Load the product on its side so the label is easy to read from the front of the machine.
5. All products should be placed across the column, not length-wise.
6. When closing the lid, make sure the latch is properly engaged and the lid is completely closed. (See **Illustration #8**)

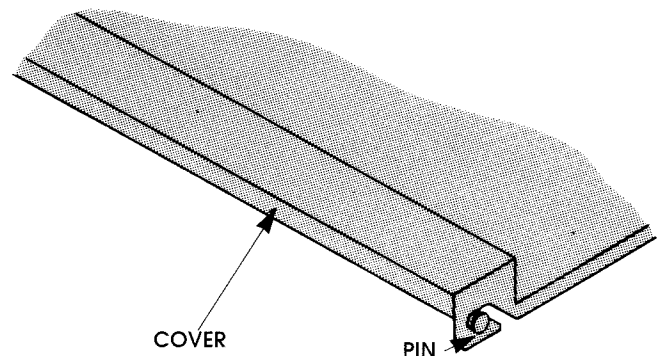

ILLUSTRATION #8

NOTE: The tray will not return to its locked position if the lid is left partially open.

INSTALLATION CONTINUED

7. Push the tray to the rear portion of the cabinet area and make sure it is securely latched in place. (See **Illustration #9**)

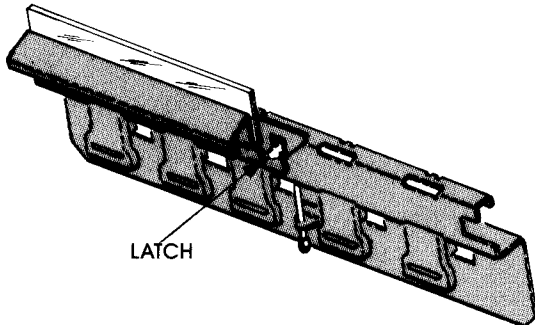

ILLUSTRATION #9

NOTE: If the tray is not properly latched it will not operate the interlock switch and the Gum & Mint unit will not operate.

SPACERS

Spacers are provided to compensate for various sizes in length and diameter and should be used when necessary to properly confine the product within the compartment.

When vending a short item in the wider compartment, installation of a spacer is necessary. To insert the removable partition, turn it to a 45 degree angle and slide it through the back until you clear the front bracket. (See **Illustration #10**)

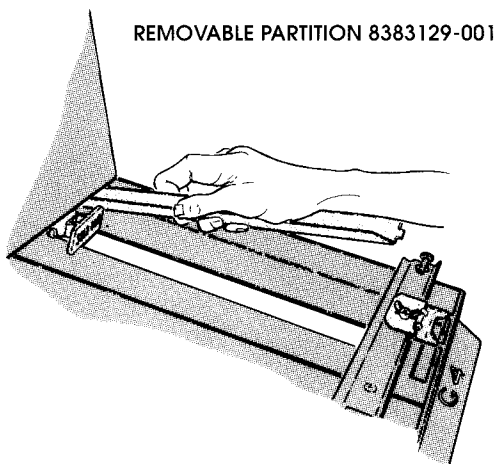

ILLUSTRATION #10

Turn the partition back to the upright position, and slide forward until the end slips into the notch in the product window. The back end should then fall into a notch at the rear of the tray. (See **Illustration #11**)

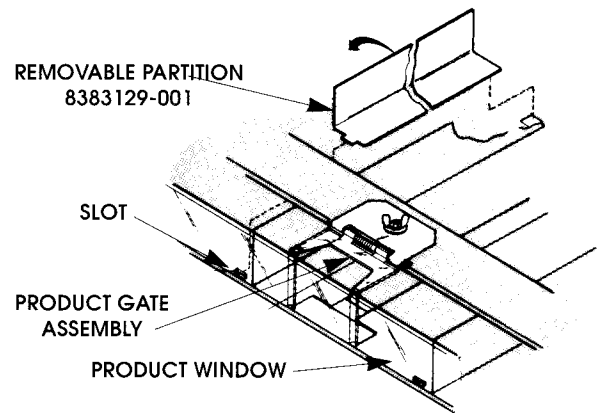

ILLUSTRATION #11

When adding the spacer, make sure that the item fits freely between the left wall of the compartment and the spacer. (See **Illustration #12**)

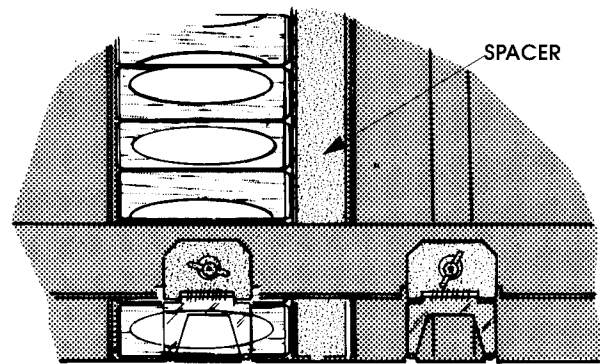

ILLUSTRATION #12

If the item does not have adequate clearance the spacer should not be used. When vending small diameter items (i.e. "Roloids", "Tums", etc.) installation of a spacer is required. These spacers must be added to prevent "pyramiding" or staggering in the column. (See **Illustration #13**)

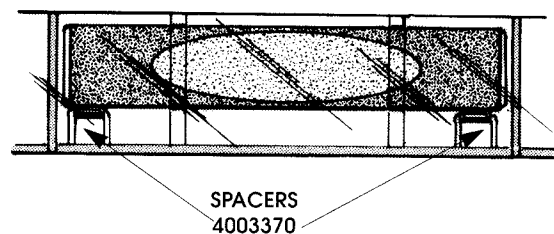

ILLUSTRATION #13

CONFIGURATION

CHANGING MACHINE CONFIGURATION

The design of the Glassfront Merchandiser allows changing the tray configuration and spacing of the trays on location. The capability to rearrange tray spacing, auger pitch, the number of selections per tray and various combinations of auger types gives the customer the flexibility to "mix-and-match" products and prices to fit specific location needs.

CHANGING TRAY SPACING

The spacing between each tray can be altered in one (1) inch increments to compensate for various heights of products. When changing the spacing between two trays, the height between the adjoining tray will be reduced or increased by the same amount.

To change tray spacing, follow the steps outlined below:

1. Remove the tray from the machine where the spacing is to be changed.
 - Pull out on the tray until it contacts the tray stop. Raise upward on the rear of the tray to remove it from the machine.
2. Move both the left and right side rails to the new position.

NOTE: Rails **MUST** be level and have the same spacing on each side.

3. Re-insert the tray assembly, making sure the tray harness mates properly with the cabinet harness. (located behind the control panel). (See **Illustration #14**)

NOTE: If a tray spacing is moved more than 4 inches the harness should also be moved in order for the tray harness to slide freely.

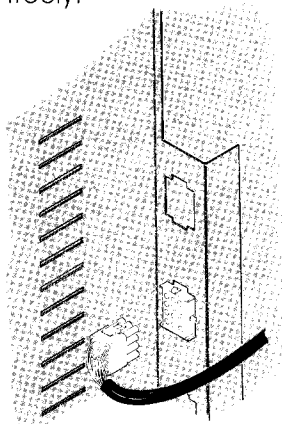

ILLUSTRATION #14

4. Place the controller in the "Service Mode" by depressing the service mode button, located on the control board. (See **Illustration #15**)

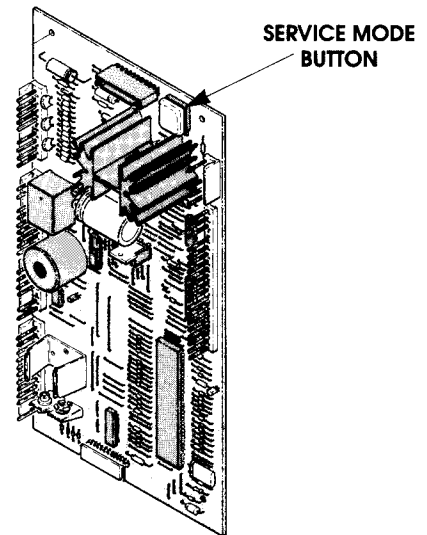

ILLUSTRATION #15

5. Push the number 2 on the key pad and note the number displayed. This should agree with the total number of selections in the machine.
6. Return to the "Sales Mode" by depressing the service mode button.
7. Test vend the tray selections that were relocated.

CONFIGURATION CONTINUED

CONVERTING TRAY CONFIGURATION

The "mix-and-match" design of the product tray provides easy conversion of the compartments for vending different sized items. The two (2) or one (1) compartment sections can be rearranged on location. The electronic control system includes all the necessary software and each tray has the necessary harnessing for each compartment re-configuration.

If necessary, parts are available for converting. Kits are available from your local distributor or (**Selectivend Inc. / P.O. Box 488 / Waukegan, Iowa 50263-0488**).

Listed below are the kits that are available to convert a "CANDY TO SNACK" or "SNACK TO CANDY" type compartments.

AUGER TYPE	PRODUCT SIZE			KIT PART NO.
	WIDTH	THICK	ITEMS	
"CANDY"	2-3/4	1-3/16	15	1200137-070
	2-3/4	15/16	18	1200137-071
	2-3/4	21/32	24	1200137-072
	2-3/4	1/2	30	1200137-073
	2-3/4	1-1/2	12	1200137-074
	2-3/4	2-1/32	9	1200137-075
"SNACK"	2-3/4	3-3/32	6	1200137-076
	5-1/2	1-13/16	10	1200137-077
	5-1/2	1-1/2	12	1200137-078
	5-1/2	1-3/16	15	1200137-079
	5-1/2	2-11/16	7	1200137-080
	5-1/2	2-5/8	8	1200137-081

PRODUCT SPACERS

Product spacers are supplied to be used when "Narrow" items are being vended. Adjust the spacer to loosely contain the product toward the right side of the compartment, forcing the product to stand upright. To adjust the spacer, pull forward to make the space narrower and push back to make the space wider. (See **Illustration #16**)

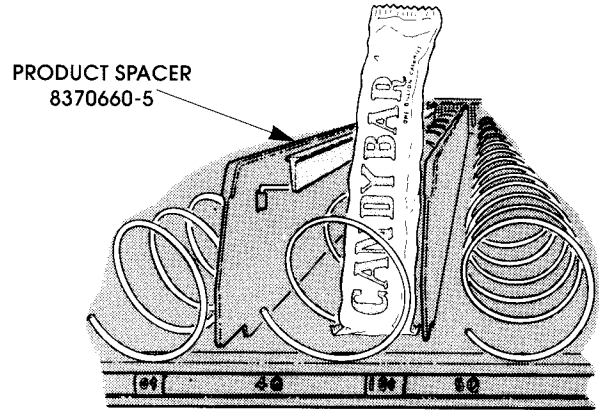

ILLUSTRATION #16

PRODUCT PUSHERS

Product pushers can be used on bag items such as peanuts or other similar products. The pushers will assist in pushing the item off the tray. The pusher "snaps" over the wire at the end of the auger. The pusher acts as an extension for the item being vended and will push the item further off the tray. (See **Illustration #17**)

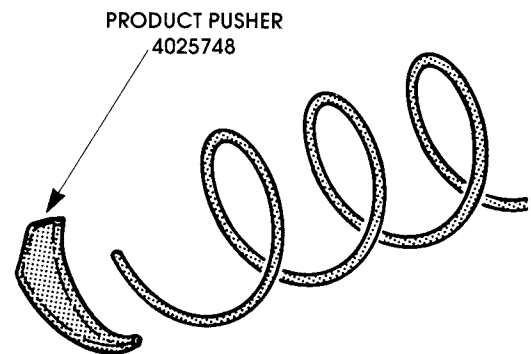

ILLUSTRATION #17

NOTE: When loading any soft product items (i.e. pies, cookies, etc.), they should be placed in the lowest possible compartment to prevent damage from the drop.

CONFIGURATION CONTINUED

CONVERSION INSTRUCTIONS (Candy to Snack)

1. Unplug and remove the tray assembly from the vendor. Place the tray harness in tray before removal.
2. Remove the motor cover and retain the cover and thumb screws.
3. Remove existing tray divider and discard.
4. Remove existing auger assemblies.
5. Remove the "even" numbered motor.
6. Dress terminals removed from the motor around the tray harness and tape in place.
7. Move "odd" numbered motor to the center slot of the compartment.
8. Install the auger retainer furnished as part of the conversion kit.
9. Install auger assembly furnished as part of the conversion kit, making sure the motor coupling properly engages with the motor and is securely snapped over the locating rail on the tray. (See **Illustration #18**).
10. Install price label, making sure it covers the "even" selection number in the tray compartment.
11. Re-assemble the motor cover retained in Step 2 and secure with thumb screws.
12. Replace the tray assembly into the vendor, making sure that the tray is properly located and latched.
13. Set the selection to the desired vend price.

NOTE: In large item selections, the selection numbers will be the "odd" numbers.

EXAMPLE: Selection C3 and C4 converted to a single compartment, the selection number would become C3.

14. Test vend for proper operation.

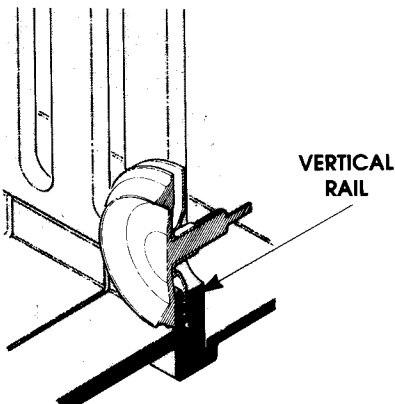

ILLUSTRATION #18

CONVERSION INSTRUCTIONS (Snack to Candy)

1. Unplug and remove the tray assembly from the vendor. Place the tray harness in tray before removal.
2. Remove the motor cover and retain the cover and screws.
3. Remove existing auger assembly and discard.
4. Remove auger retainer and discard.
5. Move motor from center slot to the left slot in the compartment.
6. Add new motor furnished as part of the conversion kit in the right hand slot of the compartment.
7. Properly wire the motor and switch. (Refer to wiring diagram for wire colors and locations.)
8. Add divider furnished as part of the conversion kit.
9. Install new auger assemblies furnished as part of the conversion kit, making sure the motor coupling properly engages with the motor and is securely snapped over the locating rail on the tray. (See **Illustration #18**)
10. Install price labels next to odd selections.
11. Re-assemble the motor cover removed in Step 2 and secure with thumb screws.
12. Replace the tray assembly into the vendor, making sure that the tray is properly located and latched.
13. Set the selections to the desired vend prices.
14. Test vend the converted selections for proper operation.

AUGER SIZES AVAILABLE				
AUGER TYPE	PRODUCT SIZE			AUGER PART NO.
	WIDTH	THICK	ITEMS	
CANDY	2-3/4	1-3/16	15	4200272-000
	2-3/4	15/16	18	4200272-001
	2-3/4	21/32	24	4200272-002
	2-3/4	1/2	30	4200272-003
	2-3/4	1-1/2	12	4200272-004
	2-3/4	2-1/32	9	4200272-005
	2-3/4	3-3/32	6	4200272-006
SNACK	5-1/2	1-13/16	10	4200272-007
	5-1/2	1-1/2	12	4200272-008
	5-1/2	1-3/16	15	4200272-009
	5-1/2	2-11/16	7	4200272-010
	5-1/2	2-5/8	8	4200272-011

NOTE: For assistance or if replacement parts are needed see **Illustration #19**.

CONFIGURATION CONTINUED

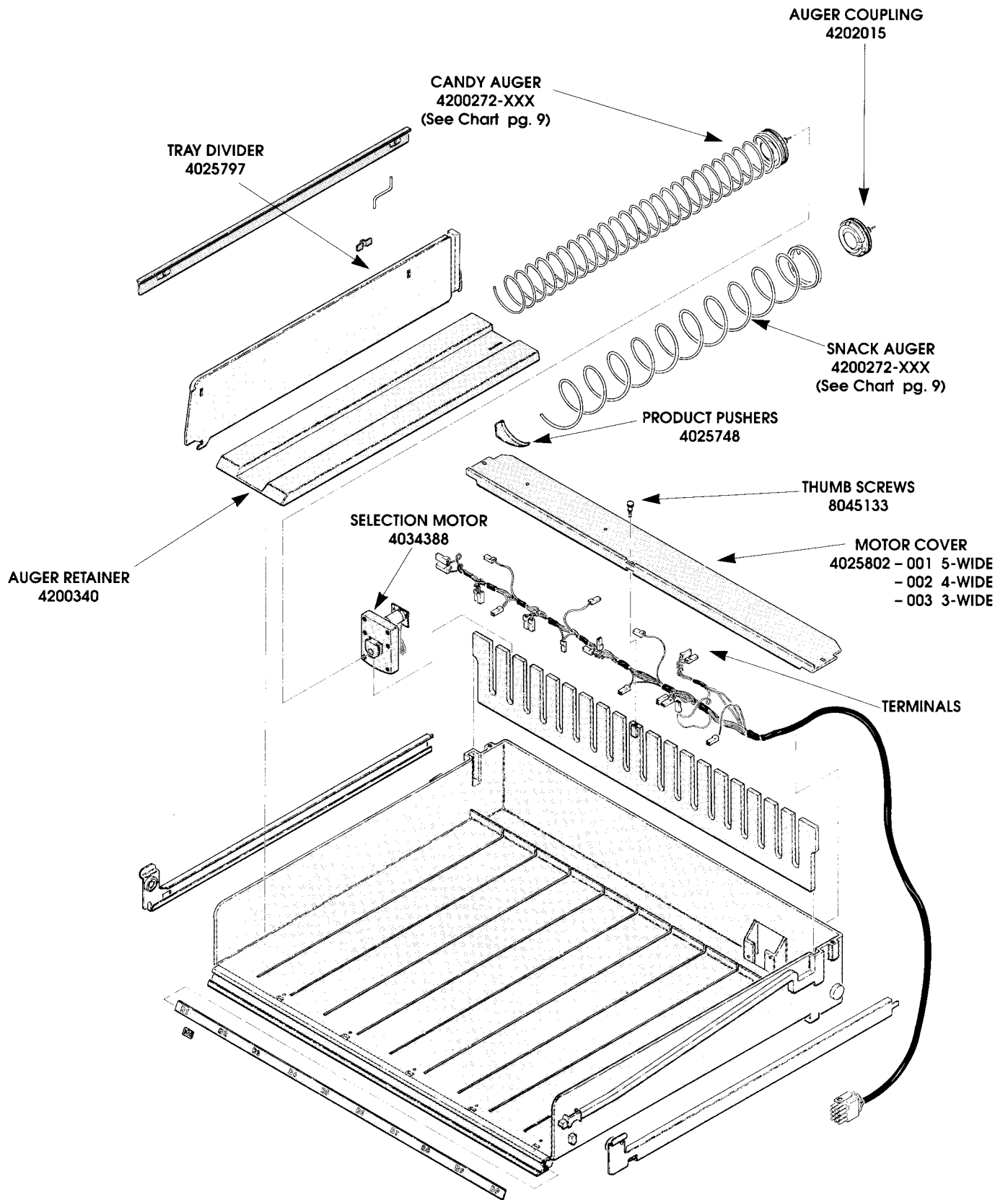

ILLUSTRATION #19

CONTROLLER FUNCTIONS

SALES MODE

The "Sales Mode" is the normal operating mode of the vendor. When in the "Sales Mode" the controller will communicate with the buying customer with instructions pertaining to the vend requirements.

The following messages will be displayed while the vendor is in the "Sales Mode".

DISCOUNT AVAILABLE NOW MESSAGE

This message will be displayed when the discount feature has been programmed into the controller and the feature becomes active. Refer to **Discount Feature Section** for instructions on setting the discount and activating this feature.

POINT OF SALES MESSAGE

This is a programmable 130 character sales message and is usually an encouragement to the buying customer to purchase the products. The message is displayed in a scrolling format and will appear continuously while the machine is in "stand-by" condition and the coin mechanism has an adequate supply of coins in the change tubes. If the change supply in the coin mechanism is below the "low level" sensors in the pay out tubes, the "**EXACT CHANGE ONLY**" message will appear.

EXACT CHANGE ONLY MESSAGE

This message will be displayed when the change supply in the coin mechanism is below the "low level" sensors in the change tubes. When the pay-out tubes are low, the "**EXACT CHANGE ONLY**" message takes priority over the "Point of Sales" message and the Discount Available Now Message.

The following will define the standby condition of the Glassfront Merchandiser along with the step-by-step operation during a normal vend cycle with credit inserted to equal or exceed the vend price of the item selected.

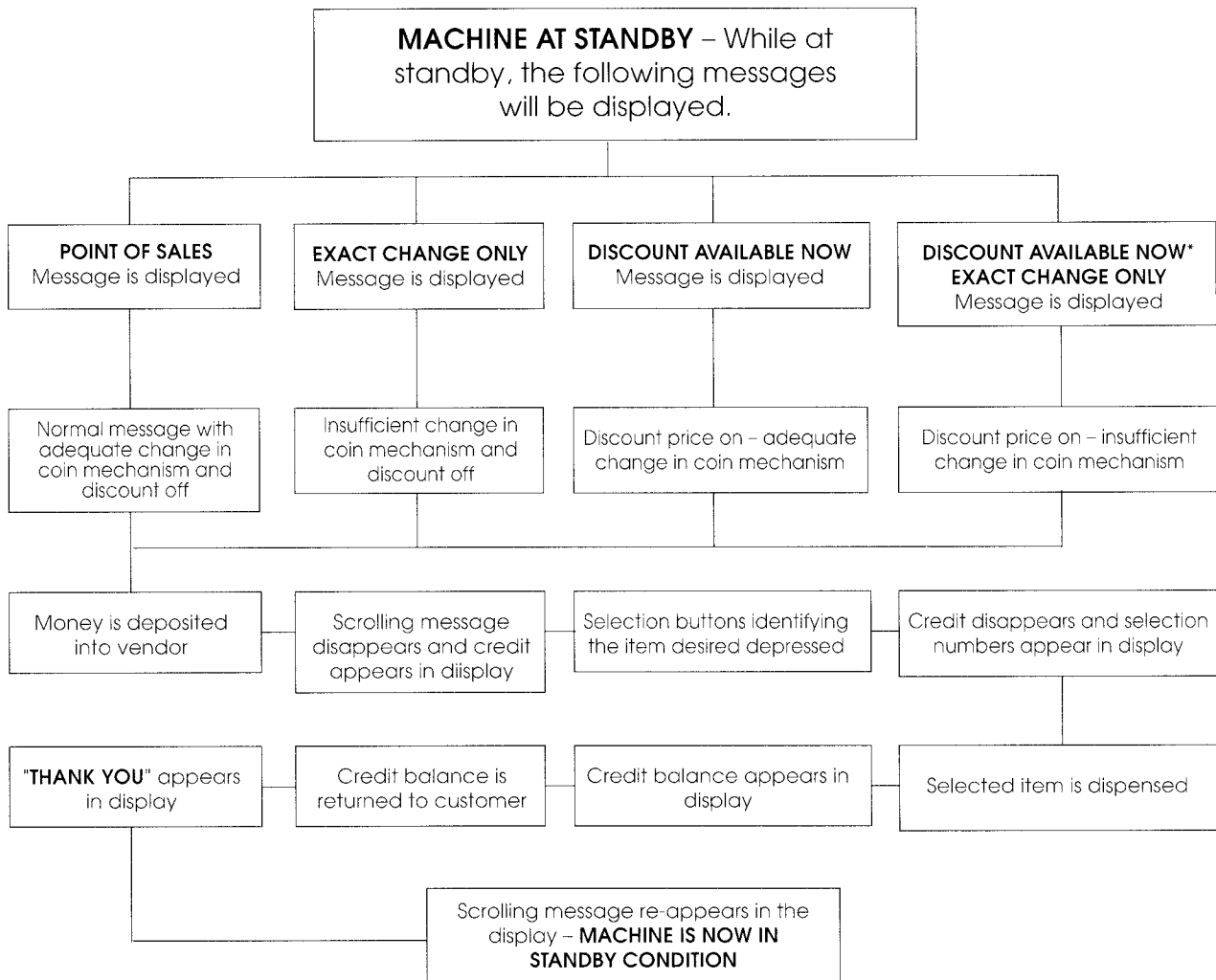

CONTROLLER FUNCTIONS CONTINUED

SERVICE MODE

The "Service Mode" will allow the service personnel access to the programming functions of the controller. The controller must be placed in the "Service Mode" to alter any programming, establish new programs, retrieve diagnostic information and other features.

When the controller is placed in the "Service Mode", faulty selections that have been recorded will appear in the display. Any information displayed in the digital display should be recorded immediately. Any input or key depression on the key pad will remove this information from the controller's memory and the failures will not be displayed again until that specific failure has been repeated during normal vend cycles. See the **Diagnostics and Trouble Shooting Sections** for further details pertaining to motor failure.

When in the "Service Mode" the keys on the key pad will perform different functions depending on the specific mode, or requirements of the program to be accomplished. The "key" functions will be defined in detail under each mode description throughout this manual. Furnished in the service packet is a key pad over lay that can be placed over the key pad to illustrate the programming functions.

To place the controller in the "Service Mode", depress the service mode button located on the control board. (See **Illustration #20**)

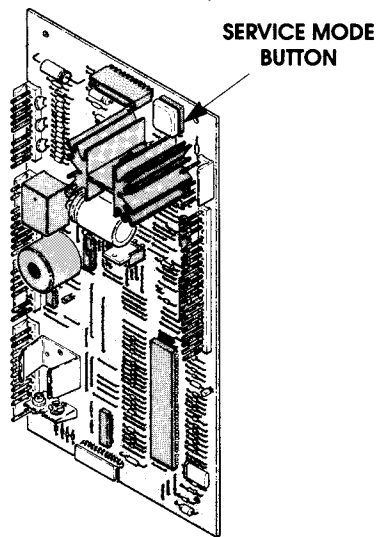

ILLUSTRATION #20

Record any diagnostics that appear in the display. If no diagnostics are displayed, no electrical problems with the motors were detected by the controller since the last depression of the "Service Mode" switch.

NOTE: The controller will automatically exit the "Service Mode" and enter the "Sales Mode" in 25 seconds if no input or depression of the key pad is made during that time. Each depression or input will allow for another 25 seconds before the controller times out.

The following chart can be used as a "quick reference" for entering or changing programs in the Glassfront Merchandiser. Complete details and steps for individual modes are outlined throughout the service manual.

Place the controller in the "Service Mode" by depressing the "Service Mode" button located on the control board.

Follow the steps outlined below:

MODE KEY	FUNCTION/ MODE	TO PROGRAM - ENTER THE FOLLOWING
1	COIN DISPENSE	1 + A = 5c 1 + B = 10c 1 + C = 25c
2	MOTOR COUNT	2 = NUMBER OF MOTORS SELECTION
3	FORCE VEND	3 + A = FORCE VEND "ON" 3 + A = FORCE VEND "OFF"
	MULTI VEND	3 + B = MULTI VEND "ON" 3 + B = MULTI VEND "OFF"
	PROMO VEND	3 + C = PROMO VEND "ON" 3 + C = PROMO VEND "OFF"
4	LANGUAGE	4 + E = ENGLISH
5	SET PRICE	5 + (SEL.) + (PRICE) + #
	COPY PRICE	5 + (SEL.) + (PRICE) + * + (SEL.) + (SEL.) ... + #
6	VEND COUNT	6 + A = TOTAL VENDS 6 + B = TOTAL CASH
	MESSAGE	7 + (MESSAGE) + NEXT MENU + ENTER
8	TEST VEND SEL.	8 + (SEL.)
9	TEST VEND ROW	9 + (ROW)
0	TEST VEND MACHINE	0 = TEST VEND
*	SET TIME (CLOCK)	* + A + (TIME OF DAY) + #
	SET TIME (DISC.)	* + B + (TIME) + # = START 1 * + C + (TIME) + # = STOP 1 * + D + (TIME) + # = START 2 * + E + (TIME) + # = STOP 2 * + F + (TIME) + # = START 3 * + G + (TIME) + # = STOP 3
#	DISCOUNT CONTROL	# + A = DISCOUNT "ON" # + A = DISCOUNT "OFF"
	SET AMOUNT	# + B + (AMOUNT) + #
	SET ROW/ROWS	# + C + (FIRST ROW) + #

CONTROLLER FUNCTIONS CONTINUED

DIAGNOSTICS

Each time the controller is placed in the "Service Mode", failures pertaining to the electrical circuit to the vend motors will be displayed if a particular selection failed to vend when selected by the buying customer. If an item is selected and the vendor is unable to complete the vend, the controller will display to the buying customer "**MAKE OTHER SELECTION**", and that particular selection will be removed from the program. The faulty selection will remain inoperative until cleared or repaired.

Each time the controller is switched in or out of the "Sales Mode" or "Service Mode", the motor circuits are scanned to determine the number of active or operational motors at that time. The diagnostics being displayed indicate the selections that were functional when the "Sales Mode" was last activated, however, due to failures or removal, are not in the circuit now. For instance, if a tray is not properly connected with the main cabinet harness, these selections would appear as faulty when the "Service Mode" is entered.

Faulty motor selection numbers will be displayed in a rotational sequence. If no selection numbers are displayed in the display when the controller is first placed into the "Service Mode", no electrical problems with motors were detected since the last depression of the "Service Mode" switch.

It is **IMPORTANT** that the information displayed be recorded immediately. Any input or key depression of the key pad will remove this information from the controller's memory and the failures will not be displayed again until that specific failure has been repeated during a normal vend cycle.

The selection number indicates the area where the problem was detected and will assist service personnel in isolating the source or cause of the problem.

NOTE: Exiting the "Service Mode" or advancing to another step by depressing the key pad will remove the diagnostics from the controller's memory.

CONTROLLER FUNCTIONS CONTINUED

POINT OF SALES MESSAGE MODE

Provisions have been incorporated into the controller for a point of sales message that will be displayed to the buying customer. This message can be used by the owner/operator as advertising or an encouragement to the buying customer to purchase the products. The point of sales message will appear continuously while the machine is in a standby condition as long as the coin mechanism has an adequate supply of coins in the payout tubes. If the change supply in the coin mechanism is below the "low-level" sensor in the payout tubes, the **"EXACT CHANGE ONLY"** message will appear.

The sales message can be changed on location by accessing the point of sales message mode. Messages can include up to 130 characters including spaces. While in the programming mode the key pad will function similar to a typewriter keyboard. A key pad overlay is furnished in the service packet. By placing the overlay over the selection panel, the owner/operator can "type" the new message into the controller's memory.

To enter the programming mode, the controller must first be placed in the "Service Mode", then enter the "Point of Sales Mode". The following outlines the steps to be taken:

1. Set the controller in the "Service Mode" by depressing the "Service Mode" button on the control board. (See **Service Mode Section**)
2. Enter "Point of Sales Message Mode" by depressing key "7" on the front panel key pad.
3. Type in the new message (maximum of 130 characters, including spaces).
 - Use the key pad overlay for location of characters on the key pad.
4. Enter the message into the controller's memory by depressing the "Next Menu" key twice.

NOTE: If the key's defined in **STEP 4** are not entered properly when the programming of the new message is complete, portions of the previous message may appear.

When exiting the "Point of Sales Mode" message, the scrolling message will appear in the display if adequate change is in coin mechanism pay out tubes.

NOTE: When in the "Point of Sales Mode" the buttons have different functions.

A	1	2	<div style="border: 1px solid black; padding: 5px; display: inline-block;">P.O.S.M</div>
B	3	4	
C	5	6	
D	7	8	
E	9	0	
F	*	#	
G	H	J	

NOTE: When in the "Point of Sales Message" Mode the buttons have different functions, see sketch below for key functions.

NOTE: The upper characters in each block are accessed directly by depressing the desired key while the bottom characters in each block can only be accessed by depressing the "Next Menu" key each time those characters are needed.

A	G	N
K	Y	4
B	H	O
Q	Z	5
C	I	P
U	Ø	6
D	J	R
V	1	7
E	L	S
W	2	8
F	M	T
X	3	9
SPACE	NEXT MENU	BACK SPACE
*	ENTER	\$

CONTROLLER FUNCTIONS CONTINUED

PRICE SETTING INSTRUCTIONS

All pricing is controlled by the controller and must be programmed into the controller's memory. The vend prices can only be programmed while in "Service Mode". Vend prices are programmed into the memory of the controller by using the key pad to input the commands or requirements.

A vend price must be established for each selection. On items that will be vended at the same vend price, the "Copy Price Mode" can be used to duplicate the prices.

To establish vend prices, follow the steps outlined below:

1. Place the controller in the "Service Mode".
 - This is done by depressing the "Service Mode" button located on the control board. (See **Service Mode Section**)

NOTE: The display will indicate any faulty selections that have been recorded by the controller. These faults should be noted immediately. Refer to the **Trouble Shooting** section of this manual for additional information.

2. Enter the "Price Mode" by depressing key "5" on the front panel key pad.
 - The display will indicate **"MAKE SELECTION"**.
3. Enter the selection **letter** and **number** of the item to be priced.
 - The selection number and current vend price will be displayed.
4. Enter the desired vend price using the number keys on the front panel key pad.

EXAMPLE: If the numbers 1, 2 and 5 were entered, that item would have a vend price of \$1.25.

5. Store the price in memory by depressing the "#" key on the front panel key pad, or use "Copy Price Mode".
6. Continue setting prices for other selections by repeating **Steps 3 through 5** or by using the "Copy Price Mode" instructions.
7. After completing price setting, depress the "Service Mode" button located on the control board.
 - The scrolling message will appear in the display. The machine is now in the "Sales Mode".
8. Check prices of items programmed by depressing selections in the "Sales Mode".

NOTE: Any time the controller is placed in the service mode it will automatically return to the sales mode in 25 seconds if no input or depression of the key pad is made during that time.

IMPORTANT: When establishing vend prices, make sure the price label located on the product tray agrees with the vend prices programmed into the controller and that they are properly located below the item they are identifying.

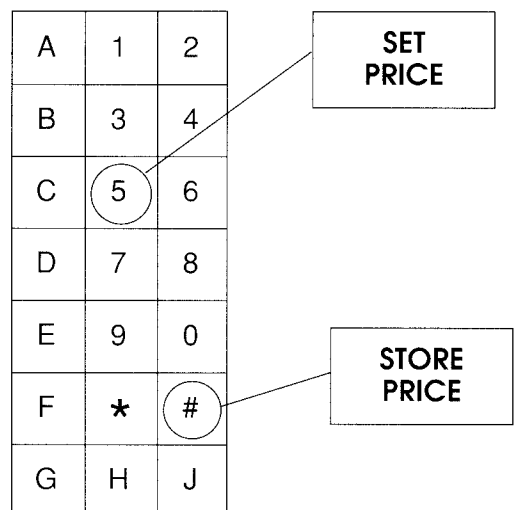

The following "flow chart" indicates the basic steps that are required when establishing vend prices on individual selections. If more than one selection is being vended at the same vend price, the "Copy Price Mode" can be used:

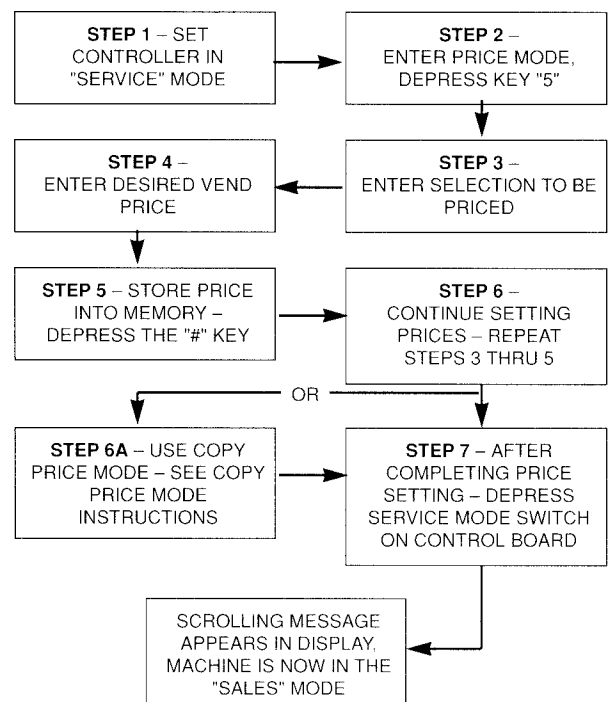

CONTROLLER FUNCTIONS CONTINUED

COPY PRICE MODE

When there is more than one selection to be vend at the same vend price, the "Copy Price Mode" can be used to duplicate prices for these selections. The "Copy Price Mode" can be accessed by following the instructions outlined below.

1. Place the controller in the "Service Mode". (See **Service Mode Section**)
 - This is done by depressing the "Service Mode" button located on the control board.
2. Enter the "Price Mode" by depressing key "5" on the front panel key pad.
 - The display will indicate **"MAKE SELECTION"**.
3. Enter the selection to be priced.
 - The selection number and current vend price will be displayed.
4. Enter the desired vend price using the number keys on the front panel key pad.

EXAMPLE: If the numbers 1, 2 and 5 were entered, that item would have a vend price of \$1.25.

5. Depress the "*" key on the front panel key pad.
 - **"COPY PRICE"** will appear in the display.
6. Enter the desired selections to receive the Copy Price. All selections entered will receive the same vend price.
7. Store the prices in memory by depressing the "#" key on the front panel key pad.
8. To continue to copy another price, repeat **Steps 3 through 7**.
9. After completing price setting, depress the "Service Mode" button on the control board. Scrolling message will appear in the display. The machine is now in the "Sales Mode".

The following flow chart indicates the basic steps that are required when establishing vend prices using the "Copy Price" option. When establishing prices for individual selections, follow the instructions outlined under **"Price Setting Instructions"**.

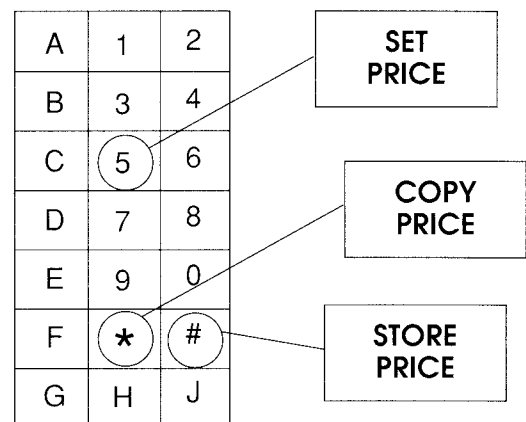
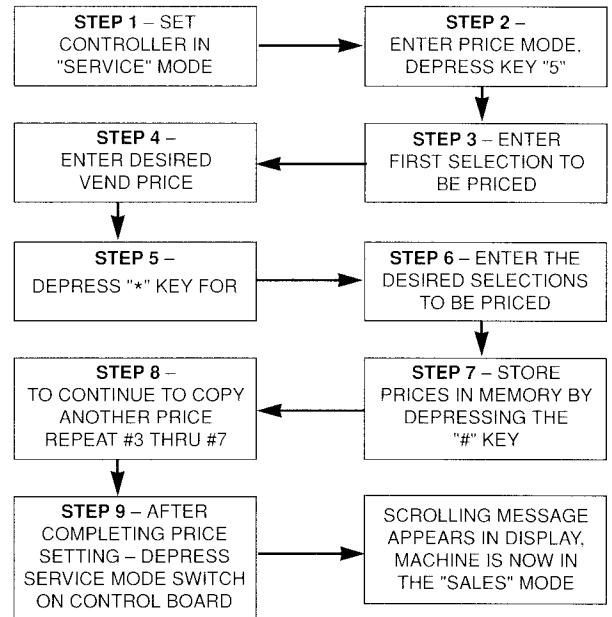

VERIFYING VEND PRICES

The vend price for each selection can be verified at any time while the machine is in the "Sales Mode". To verify the price programmed into the controller, depress the specific selection numbers and the current vend price will be displayed for approximately three seconds. The price for each selection must also be identified by a "price label" on the tray under each product. Make sure the price programmed into the controller agrees with the label affixed to the tray for each selection.

NOTE: When the controller is in the "Discount Mode" and a time interval has been activated, the discounted price will be displayed. If that specific selection has been recorded as a faulty motor or has been removed by the controller, **"SELECT OTHER ITEM"** will be displayed. This indicates that the selection is not functional.

CONTROLLER FUNCTIONS CONTINUED

COIN DISPENSE MODE

In the "Coin Dispense Mode", coins that are stored in coin mechanism pay out tubes can be removed. To access the "Coin Dispense Mode" the controller must first be placed in the "Service Mode" by depressing the Service Mode button located on the control board. (See **Service Mode Section**)

The "Coin Dispense Mode" is accomplished as follows:

1. Depress key "1" – "**DISPENSE \$**" will be displayed.
2. Depress key "A" – The Nickel pay-out tube will be activated.
3. Depress key "B" – The Dime pay-out tube will be activated.
4. Depress key "C" – The Quarter pay-out tube will be activated.

Coins will continue to be dispensed from the pay-out tubes as long as its activating key is depressed.

A	1	2	COIN DISPENSE
B	3	4	
C	5	6	
D	7	8	
E	9	0	
F	*	#	
G	H	J	

1 + A = 5c
1 + B = 10c
1 + C = 25c

NOTE: Exit the "Coin Dispense Mode" by entering any other "function" key or by exiting the service mode by depressing the "Service Mode" button on the control board. (See **Service Mode Section**)

MOTOR COUNT MODE

The "Motor Count Mode", when operated causes the controller to indicate the total number of functional motors that are in the system. This number should agree with the total number of selections that are in the machine. Only the total number of motors will be flashed. Individual selection numbers will not be displayed. The motor count command is accomplished as follows:

1. Enter "Service Mode".
2. Depress key "2" – The number of functional motors will be briefly flashed in the digital display.

NOTE: The motor count can be displayed again by pressing and holding key "2", the count will be displayed constantly.

MOTOR COUNT	A	1	2
	B	3	4
	C	5	6
	D	7	8
	E	9	0
	F	*	#
	G	H	J

If the motor count displayed does not agree with the total number of selections in the machine, this indicates that the electrical circuit of all motors is not complete. The service person should determine what motor/motors are not functioning. Listed below are suggested steps to be taken.

1. Were faulty motors displayed when placed in the service mode?
 - Problem would be in these areas.
2. Test vend all selections.
 - Problem; faulty selection will not vend.
3. Refer to the **Trouble Shooting** section of this manual for further assistance.

NOTE: Exit the "Motor Count Mode" by entering any other function key or exit the "Service Mode" by depressing the Service Mode button on the control board. (See **Service Mode Section**)

CONTROLLER FUNCTIONS CONTINUED

TEST VEND MODES

The operational functions of the vendor can be verified by running various test vends. The machine can be tested by individual selections, a complete row, or all selections in the entire machine. When the test commands are entered, the controller will check the motor circuit and run the selection through a complete vend cycle if the circuit is complete and the motor is functional. If the motor is not functional, or the motor circuit is not complete on a particular selection, the test function will not be made.

The controller will acknowledge all commands that can be performed by a single "beep" sound. Three "beeps" will be heard when a command cannot be performed. It will be necessary for the service person to observe the testing operation. Verifying that the functions are being performed, as the controller will also sound three "beeps" for selections that are not configured in the machine.

NOTE: The testing functions and vending of the products while in the "Test Vend Mode" will not affect the records maintained by the controller pertaining to "Total Vends/Total Cash".

TEST VEND SINGLE SELECTION

Single selections can be test vend to verify that they are functioning properly. The controller will check the motor circuit and run the selection through a complete vend cycle if the circuit is complete and the motor is functional. The controller will acknowledge the commands that are being performed by a single "beep" sound. Three "beeps" will sound if a command cannot be performed.

To test vend single selections, the controller must be in the "Service Mode". Each time the service person places the controller in the service mode, any diagnostics displayed in the display should be noted. Follow the instructions below to test vend single selections:

1. Place the controller in the "Service Mode" by depressing the Service Mode button on the control board. (See **Service Mode Section**)
2. Depress key "8" on the front panel key pad. A single "beep" will sound and **"MAKE SELECTION"** will be displayed.

A	1	2
B	3	4
C	5	6
D	7	8
E	9	0
F	*	#
G	H	J

TEST VEND
SINGLE SELECTIONS

3. Enter selection to be tested. A single "beep" will acknowledge the input, the vend price of the selection will be displayed and a single product will be dispensed.

NOTE: If the product dispense cycle is successful, the display will remain blank and the system will remain in the "Service Mode" waiting for the next service command.

NOTE: If the product dispense cycle is unsuccessful, the display will remain blank, three "beeps" will sound and the system will remain in the "Service Mode" waiting for the next service command.

To test vend another selection, repeat **Steps 2 and 3** outlined above.

NOTE: To exit the "Service Mode", depress the Service Mode switch located on the control board. To enter another function mode, depress that particular function mode button.

CONTROLLER FUNCTIONS CONTINUED

TEST VEND COMPLETE ROW

All selections in a complete row can be tested to verify that they are functioning properly. The controller will check the motor circuits and run each selection in a single row, starting with the number "1" selection if the circuit is complete and the motor is functional.

Each motor will be run through a complete vend cycle and the controller will acknowledge a functional selection with a single "beep". If a selection is not functional, three "beeps" will sound indicating that the command cannot be performed and the controller will continue to the next selection.

While using the "row" test function it will be necessary to observe the testing of the selections to verify the operation as the controller will also sound three "beeps" for selections that are not configured in the machine.

Vending items while in the "Test Vend Modes" will not affect the records being accumulated pertaining to "Total Vends" or "Total Cash".

To test vend the machine by complete row, the controller must be in the "Service Mode". Each time the service person places the controller in the "Service Mode", any diagnostics displayed in the read-out should be noted.

Follow instructions for test vending complete row:

1. Place the controller in the "Service Mode" by depressing the Service Mode button on the control board. (See **Service Mode Section**)
2. Depress key "9" on the front panel key pad. A single "beep" will sound and "**MAKE SELECTION**" will appear on the display.

A	1	2
B	3	4
C	5	6
D	7	8
E	9	0
F	*	#
G	H	J

TEST VEND
COMPLETE ROW

3. Enter row (Alpha) to be tested. A single "beep" will acknowledge the input, the vend prices of the selections will be displayed and a single product of each selection will be dispensed.

NOTE: If the product dispense cycle is successful, the display will remain blank and the system will remain in the "Service Mode" waiting for the next service command.

NOTE: If the product dispense cycle of an item is unsuccessful, three "beeps" will sound and the controller will continue to the next selection. At the end of the test function the display will blank and the system will remain in the "Service Mode" waiting for the next service command.

To test vend another row, repeat **Steps 2 and 3** outlined above.

CONTROLLER FUNCTIONS CONTINUED

TEST VEND COMPLETE MACHINE

All selections in the entire machine can be tested to verify that they are functioning properly. The controller will check the motor circuits and run each selection if the circuit is complete and the motors are functional.

Each motor will be run through a complete vend cycle and a product will be dispensed. The controller will acknowledge each functional selection with a single "beep". If a selection is not functional, three "beeps" will sound indicating that the command cannot be performed and the controller will continue to the next selection.

While using the "machine" test function it will be necessary to observe the operation of the individual selections as the controller will also sound three "beeps" for selections that are not configured in the machine.

During the machine test cycle the records pertaining to "Total Vends" and "Total Cash" will not be affected.

To test vend the machine, the controller must be in the "Service Mode". Each time the controller is placed in the "Service Mode", any diagnostics displayed in the read-out should be recorded prior to inputting any service commands.

Follow instructions below to test vend the complete machine:

1. Place the controller in the "Service Mode" by depressing the Service Mode button located on the control board. (See **Service Mode Section**)
2. Depress key "0" on the front panel key pad. The machine test will begin immediately starting with selection "A1".

A	1	2
B	3	4
C	5	6
D	7	8
E	9	0
F	*	#
G	H	J

TEST VEND
COMPLETE MACHINE

NOTE: All functional selections will be run through one complete vend cycle and a product will be dispensed. The machine test may be stopped at any time by depressing any "Alpha" key, other wise all selections will be cycled.

NOTE: If the product dispense cycle for individual selections is successful, the controller will sound a single "beep", the vend price will be displayed and a product will be dispensed. When the entire machine has been tested, the display will blank and the system will remain in the "Service Mode" waiting for the next service command.

NOTE: If the product dispense cycle of an item is unsuccessful, the controller will sound three "beeps" will sound and continue to the next selection. At the end of the entire machine test the display will blank and the system will remain in the "Service Mode" waiting for the next service command.

CONTROLLER FUNCTIONS CONTINUED

VEND OPTIONS MODE

Vend options are available that can be programmed into the controller. When using any of the vend options, a battery backup is required to maintain the setting. **"SEE BATTERY BACKUP OPTION"** The options allow the machine to be programmed to function as a changer without making a purchase, make multiple selections with single deposits, or vend a free item when selecting another product. The three (3) options that are available are identified as:

- "FORCE VEND"
- "MULTI VEND"
- "PROMO VEND"

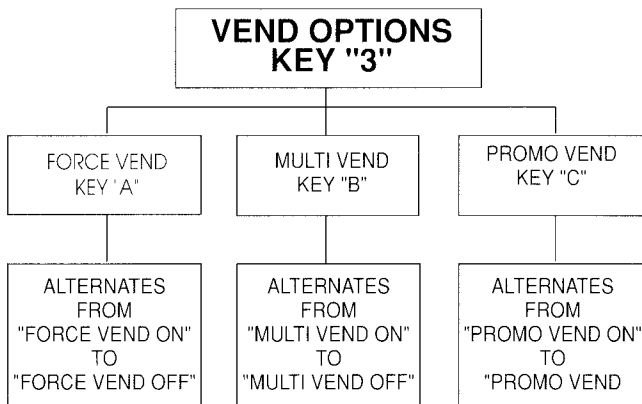

Each time the individual modes are entered, the controller will alternate from the "On" or "Off" position.

EXAMPLE: If a specific mode had been precisely programmed to the "ON" position, the next time the controller is placed in this mode it will automatically toggle the mode to the "OFF" position.

FORCE VEND OPTION

To set the "Force Vend" options, the controller must be placed in the "Service Mode" by depressing the Service Mode button located on the control board. (See **Service Mode Selection**) Depress key "3" to enter the "Option Mode".

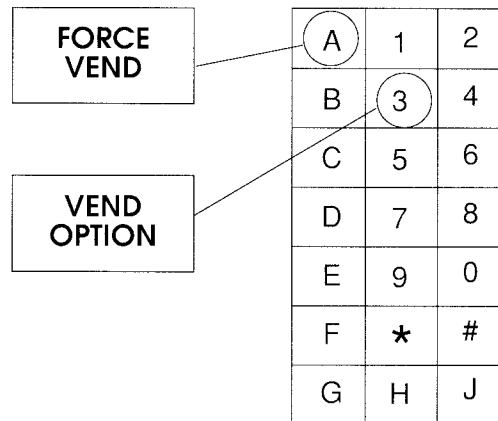

Two (2) selections are available:

1. "Force Vend On"
2. "Force Vend Off"

These options will alternately be displayed each time key "3" plus key "A" is depressed while in the Service Mode.

FORCE VEND ON: When the "Force Vend On Mode" is selected, the controller will force the customer to make a purchase when a dollar bill is inserted, overriding the "coin return" command. When in the "Force Vend On Mode", coin return of 5¢, 10¢, and 25¢ coins is not affected.

FORCE VEND OFF (Non-Escrowing Validator): When in the Force Vend Off Mode the controller will allow the customer to receive change from a dollar bill insertion when the coin return button is pressed. A purchase is not necessary.

FORCE VEND OFF (Escrowing Validator): When in the Force Vend Off Mode the controller reacts differently depending on the maximum vend price within the machine.

Example 1: Maximum Vend Price set at 95¢ or less. Dollar bill will be returned when the coin return button is pressed. A purchase is not necessary.

Example 2: Maximum Vend Price set at \$1.00 or more. The controller will allow the customer to receive change from a dollar bill insertion when the coin return button is pressed. A purchase is not necessary.

MULTI VEND OPTION

To set the "Multi Vend" options the controller must be placed in the "Service Mode" by depressing the Service Mode button located on the control board. (See **Service Mode Section**) Depress key "3" to enter the option mode.

CONTROLLER FUNCTIONS CONTINUED

Two (2) selections are available:

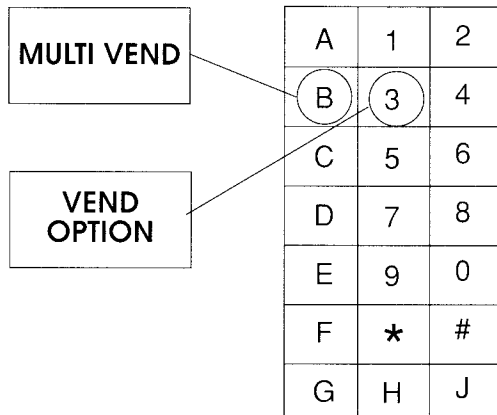

1. "Multi Vend On"
2. "Multi Vend Off"

These options will alternately be displayed each time key "3" plus key "B" is depressed while in the Service Mode.

MULTI VEND ON: When in the "Multi Vend On Mode" the "CREDIT" is flashed in the display at all times. In this mode, if the vend price of a selection is smaller than the established credit and that selection is vended, no change will be paid out. The customer can use the remaining credit to purchase other items, or push "Coin Return" to receive the balance. Multiple vend can be selected as long as adequate credit is available. When in this mode, to receive change on over-deposit the "Coin Return" button must be pushed.

MULTI VEND OFF: When in the "Multi Vend Off Mode" the controller is set in a single selection vend mode, or normal operation. Change will be returned if the established credit exceeds the vend price each time a vend is completed.

PROMO VEND OPTION

"Promo Vend" option allows the customer to receive an additional item "free" when purchasing another. Provisions have been made that item "A3" will be vended "free" each time item "A1" is selected, item "B3" will be vended "free" each time item "B1" is selected. Other selections in the machine will operate normally. Individual vends from items "A3" and "B3" can be obtained while in "Promo Vend" if these selections are depressed with adequate credit inserted.

To set the "Promo Vend" option, the controller must first be placed in the "Service Mode" by depressing the "Service Mode" button located on the control board. (See **Service Mode Section**) Depress key "3" to enter the Vend Option mode.

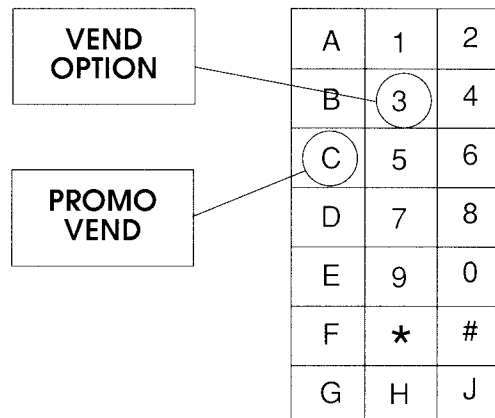

Two (2) selections are available:

1. "Promo Vend On"
2. "Promo Vend Off"

These options will alternately be displayed each time key "3" plus key "C" is depressed while in the Service Mode.

PROMO VEND ON: When in the "Promo Vend On Mode", item "A3" will be vended "free" when item "A1" is selected and item "B3" will be vended "free" when item "B1" is selected.

PROMO VEND OFF: When in the "Promo Vend Off Mode" all selections will operate normally.

NOTE: Exit the "Vend Option Mode" by entering any other "function" key, or by exiting the "Service Mode".

LANGUAGE OPTION

This mode has been incorporated for machines located outside the United States or in areas where the English language is not used. All machines shipped from the factory will be programmed in the English language unless otherwise specified on the initial order. To verify that the controller is in the proper mode for the English language, place the controller in "Service Mode" by depressing the Service Mode button on the control board. (See **Service Mode Section**) Depress key "4" plus key "E". Return the controller to the "Sales Mode" by depressing the "Service Mode" button on the control board (See **Service Mode Section**). A scrolling message will appear in the display.

CONTROLLER FUNCTIONS CONTINUED

If it becomes necessary to program the controller for a different language, place the controller in "Service Mode" by depressing the Service Mode button on the control board. (See **Service Mode Section**)

Follow the steps outlined below:

A	1	2
B	3	4
C	5	6
D	7	8
E	9	0
F	*	#
G	H	J

**LANGUAGE
OPTION**

LANGUAGE	ENTER
ENGLISH	"4" plus "E"
FRENCH	"4" plus "F"
GERMAN	"4" plus "G"
DUTCH	"4" plus "D"

LANGUAGE	ENTER
ENGLISH	"4" plus "E"
FRENCH	"4" plus "F"
ITALIAN	"4" plus "G"
SPANISH	"4" plus "D"

VEND COUNT OPTION

Provisions have been incorporated into the controller. This will allow the owner/operator to retrieve information such as "Total Cash" transactions and "Total Vend" cycles that have been performed by the vendor.

All money required for each vend is accumulated and will be displayed to the owner/operator when the "Total Cash Mode" is accessed. Total vends can also be retrieved when in the "Vend Count Mode".

These amounts are accumulated and recorded in a running total and the amounts are not resettable. Two records are maintained by the controller.

- TOTAL CASH
- TOTAL VENDS

This information can only be retrieved while the controller is in the "Service Mode". Instructions for retrieving this information are as follows:

1. Set the controller in the "Service Mode" by depressing the Service Mode button on the control board. (See **Service Mode Section**)
2. Enter the "Vend Count Mode" by depressing key "6" on the front panel key pad.
 - The display will indicate "ENTER (A) FOR TOTAL VENDS OR (B) FOR TOTAL CASH".

A	1	2
B	3	4
C	5	6
D	7	8
E	9	0
F	*	#
G	H	J

**VEND
COUNT
OPTION**

A = Total Vends
B = Total Cash

3. Depress key "A" - the total number of vends will be displayed.
4. Depress key "B" - the total amount of accumulated cash will be displayed.

NOTE: Exit the "Vend Count Mode" by entering any other "function" or by depressing the Service Mode button on the control board.

NOTE: The total vend/total cash records are not affected when using the "Test Vend" options.

CONTROLLER FUNCTIONS CONTINUED

BATTERY BACKUP OPTION

The Glassfront Merchandiser has provisions for a battery backup option that can be added to maintain time-related programs in case of power failure or any interruption of the main power source. The battery must be a rechargeable 9 volt nickel-cadmium (transistor-style) and is capable of maintaining programmed backup functions for approximately 12 hours. A charging circuit is supplied on the control board and will restore the battery when A.C. power is supplied to the vendor.

A battery backup system must be incorporated to maintain memory for the following features:

1. Real Time Clock
2. Discount Sales Programs
3. Force Vend Options
4. Multi Vend Options
5. Promo Vend Options

If the A.C. power source is interrupted or lost and a battery backup is not utilized the following will occur:

1. Clock settings will be lost.
2. Discount Sales Programs will be lost - features will default to "OFF".
3. Force-Vend Option will default to "OFF".
4. Multi-Vend Option will default to "OFF".
5. Promo-Vend Option will default to "OFF".

Other modes or settings do not require the battery backup in case of a power failure. The last program or input will be retained in the memory of the controller when the power is restored.

BATTERY INSTALLATION

To install the battery proceed as follows:

1. Turn-off or unplug the electrical power to the vendor.
2. Place battery in the clip provided on the circuit board with the battery connections aligning to the mating circuit board connectors. (See **Illustration #21**)
3. While supporting the circuit board terminal bracket, press down on the battery until contacts lock together.

CAUTION: When pressing down on the battery, be careful not to damage the power component on the circuit board.

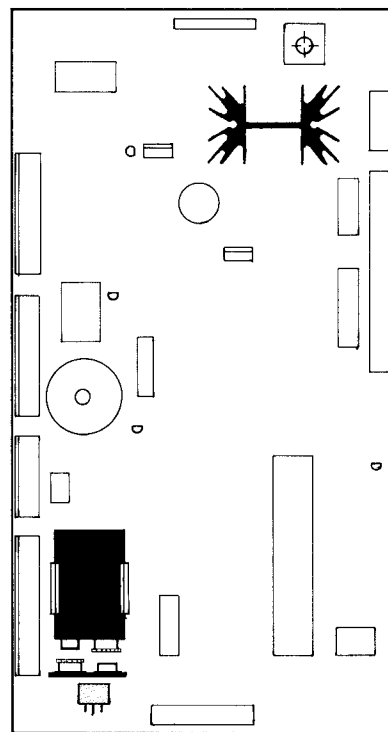

↑ BATTERY

ILLUSTRATION #21

CONTROLLER FUNCTIONS CONTINUED

SET TIME MODE BATTERY BACK UP REQUIRED

The controller is equipped with a time clock. The time will not be displayed while the vendor is in the "Sales Mode". The purpose of the clock is to control the discount program. The clock controls the start and stop times of the discount time period. In the discount program, three (3) time intervals may be selected during a 24-hour day.

The clock operates in the military format. Midnight is represented as "0000", noon is "1200", 1:00 P.M. is 1300, etc.

HOW TO SET THE TIME OF DAY

To set the time of day, place the controller in the "Service Mode" by depressing the Service Mode button located on the control board. (See **Service Mode Section**)

Press the "*" key on the front panel key pad to enter the "Time Set Mode". The message center will display "SET TIME MODE" in a scrolling format.

Press key "A" on the front panel key pad. The message center will indicate the current time setting programmed into the controller's memory.

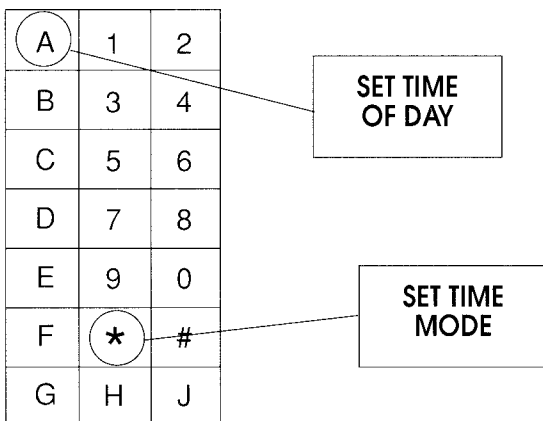

Enter the current time of day. For example, if the time is 2:15 P.M., press buttons 1,4,1 and 5 consecutively. The number will appear in the display as they are entered. When the last digit "5" is entered, the message center will display "SET TIME MODE" in a scrolling format. Enter the time by depressing the "#" key on the front panel key pad.

This concludes the time setting function and indicates that the current time is entered into the controller's memory.

The current time can be checked at any time while the controller is in the "Service Mode".

To check the time proceed as follows:

1. Press "*" key – "SET TIME MODE" will be displayed.
2. Press "A" key – Current time is displayed.
3. Press "#" key – This exits the controller from "Set Time Mode".

NOTE: Press the "#" key to abort the time setting functions. The "#" key must be depressed after checking the time or your next entry may alter the time setting.

Any time the "Time Setting" functions or "Discount" functions are to be utilized, a battery backup is required to retain the programming in the controller's memory in case of a power failure to the vendor.

NOTE: When setting the time all four digits must be entered. To set the time at 8:00 A.M. you must enter "0800", not just 800.

SET TIME MODE DISCOUNT PROGRAMMING

The controller provides the owner/operator with the ability to discount products to the buying customer. The discount programs can be made inoperative when not desired by placing the controller in the "Discount Off Mode". The vend prices of the desired items will be reduced during the time the owner chooses.

Three time intervals are provided and will operate during a 24-hour day. These programs will be repeated each day of the week when in the "Discount On Mode". The programs can be changed as often as required and can be switched "ON" or "OFF" when desired.

When the vendor is received from the factory the controller will be in the "Discount Off Mode". If the discount function is to be utilized, the following must be programmed:

1. Time intervals the discount will become active.
 - Three time intervals are available. See instructions on "How To Set Start/Stop Time".
2. The amount the product will be discounted when the program is activated. See instructions on "How To Set Discount Amount".

CONTROLLER FUNCTIONS CONTINUED

3. The items that will be discounted. See instructions on "How To Set Discount Row".

In order for the "Discount" feature to function properly, the correct time must be set. See instructions on "How To Set The Time Of Day". The battery back-up option must be utilized to retain the setting in case of a power failure.

When activating the "Discount" feature all three (3) time intervals must be programmed, as all intervals become active when the controller is in the "Discount On Mode". When the discount is in effect, the message center will display "DISCOUNT AVAILABLE NOW" in a scrolling format. If a time interval is not utilized, the following start/stop times must be programmed.

START = 0000 "Time"

STOP = 0000 "Time"

DISCOUNT PROGRAMMING HOW TO SET START/STOP TIME

To program the discount functions, the controller must be put in the "Service Mode" by depressing the Service Mode button located on the control board. Three discount time intervals are available for programming. To establish the start and stop times of the discount periods, the controller must be in the "Set Time Mode". Enter the "Set Time Mode" by depressing the "*" key on the front panel key pad. The message center will display "SET TIME MODE" in a scrolling format.

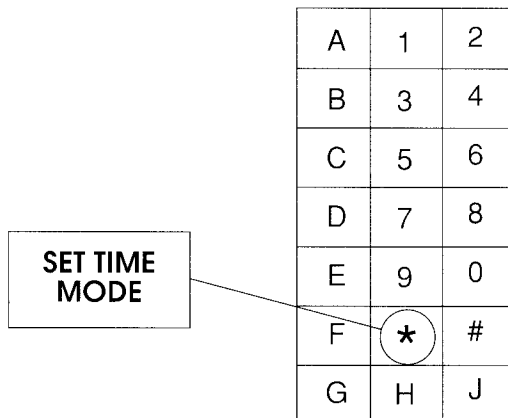

Listed below are the key pad button functions at this time:

Key "B" = Start Time, Interval #1

Key "C" = Stop Time, Interval #1

Key "D" = Start Time, Interval #2

Key "E" = Stop Time, Interval #2

Key "F" = Start Time, Interval #3

Key "G" = Stop Time, Interval #3

SETTING INTERVAL #1 START TIME

Press selection button "B". The message center will display the current discount setting start time in military format (Example: 0700). Enter the time the first discount period is to start. Each digit will be displayed as it is entered. Enter all four digits of the time.

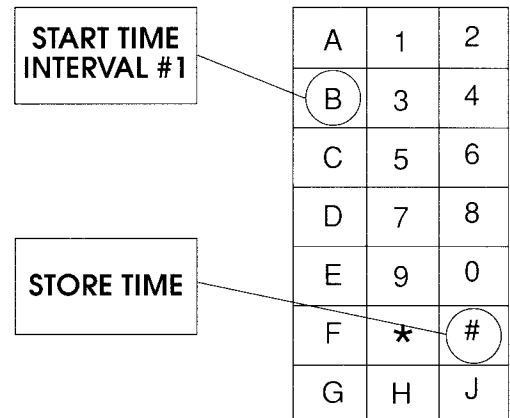

Press key "#" on the front panel key pad to store the entry in the controller's memory.

CONTROLLER FUNCTIONS CONTINUED

SETTING INTERVAL #1 STOP TIME

Press selection button "C". The message center will display the current discount setting stop time in military format (Example: 0730). Enter the time you want the first discount period to stop. Each digit will be displayed as it is entered. Enter key "#" on the front panel key pad to store the entry in the controller's memory.

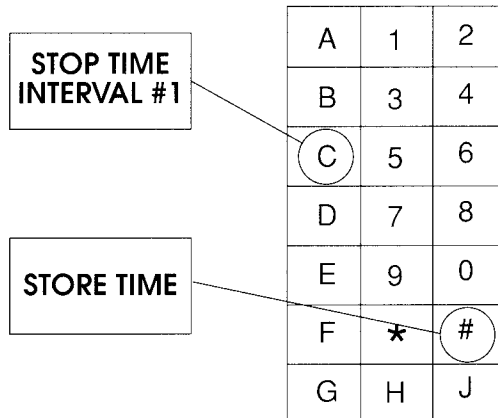

SETTING INTERVAL #2 STOP TIME

Press selection button "E". The message center will display the current discount setting stop time in military format (Example: 1130). Enter the time you want the second discount period to stop. Each digit will be displayed as it is entered. Enter all four digits of the time.

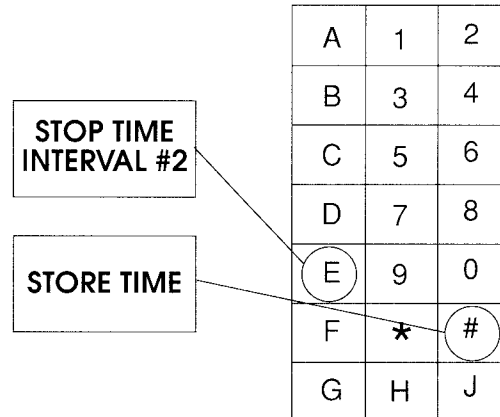

SETTING INTERVAL #2 START TIME

Press selection button "D". The message center will display the current discount setting start time in military format (Example: 1100). Enter the time you want the second discount period to start. Each digit will be displayed as it is entered. Enter all four digits of the time.

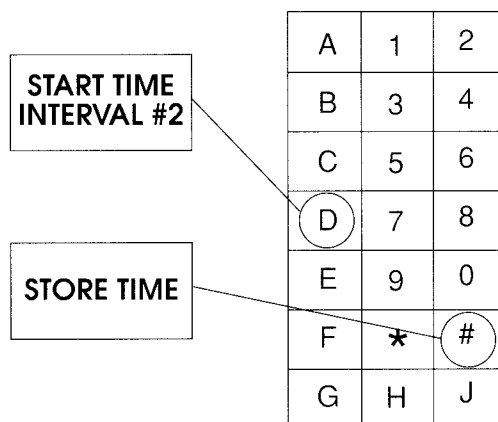

Press key "#" on the front panel key pad to store the entry in the controller's memory.

SETTING INTERVAL #3 START TIME

Press selection button "F". The message center will display the current discount setting start time in military format (Example: 1400). Enter the time you want the third discount period to start. Each digit will be displayed as it is entered. Enter all four digits of the time.

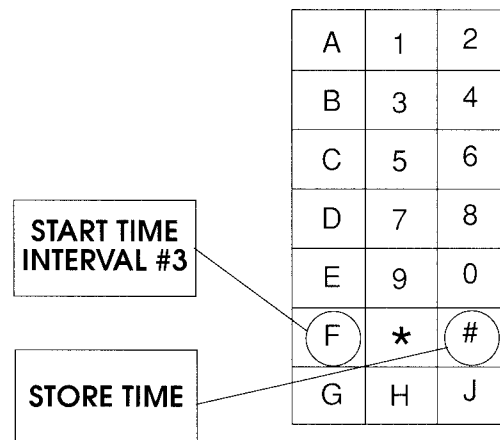

Press key "#" on the front panel key pad to store the entry in the controller's memory.

CONTROLLER FUNCTIONS CONTINUED

SETTING INTERVAL #3 STOP TIME

Press selection button "G". The message center will display the current discount setting stop time in military format (Example: 1415). Enter the time you want the third discount period to stop. Each digit will be displayed as it is entered. Enter all four digits of the time.

Press key "#" on the front panel key pad to store the entry in the controller's memory.

The following flow chart will indicate the basic steps and key inputs required for establishing the "Start" and "Stop" times for the three time intervals necessary for the discount feature:

NOTE: The "#" key **MUST** be depressed after each time setting or the next entry may alter the previous entry.

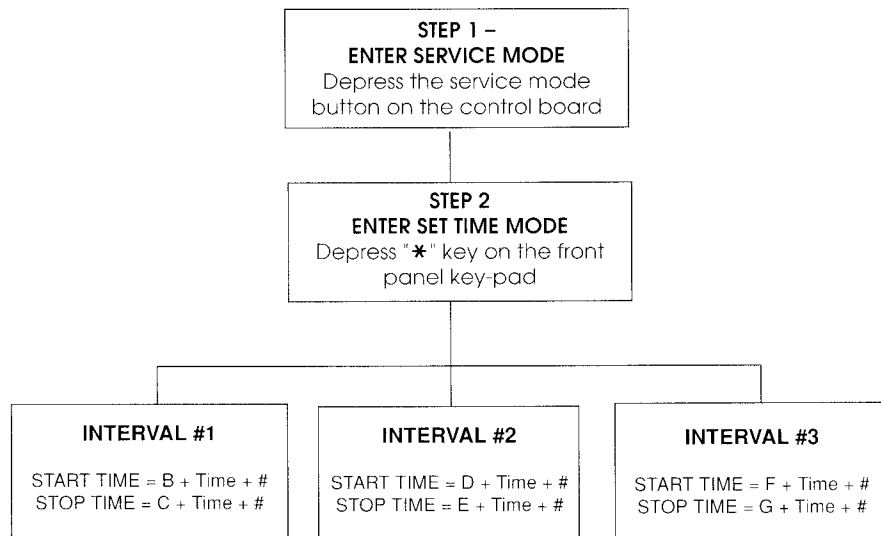
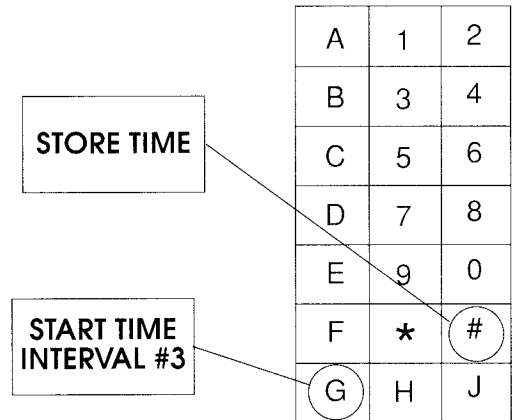

CONTROLLER FUNCTIONS CONTINUED

HOW TO SET DISCOUNT "ON/OFF"

The controller provides the option for you to set the discount program "ON" or "OFF" as desired. When the discount program is activated, the vend prices of selected items will be reduced by the amount previously determined during the time intervals that have been programmed. When the "Discount" is in effect, the message center will display **"DISCOUNT AVAILABLE NOW"** in a scrolling format.

To program the "ON" and "OFF" options of the discount functions the controller **MUST** be put in "Service Mode" by depressing the button located on the control board. (See **Service Mode Section**)

Follow the steps below for programming:

1. Enter the "Service Mode". Depress Service Mode button. (See **Service Mode Section**)
2. Enter the "Discount Mode". Depress key "#" and the message center will display **"DISCOUNT MODE"**.
3. Depress key "A". The "Discount Mode" will be toggled "ON" or "OFF" each time entered.

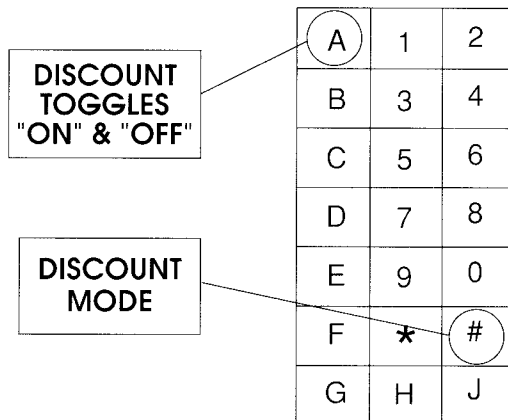

4. Depress "#" key to store the input in the controller's memory.

HOW TO SET DISCOUNT AMOUNT

When utilizing the "Discount" feature the amount must be programmed into the controller. When the "Discount" is in effect, the message center will display **"DISCOUNT AVAILABLE NOW"** and the original vend price will be reduced by this amount each time a vend is made.

To program the amount the items will be discounted the controller must be put in "Service Mode" by depressing the Service Mode button

located on the control board. (See **Service Mode Section**)

Follow the steps below for programming:

1. Enter the "Service Mode". Depress Service Mode button. (See **Service Mode Section**)
2. Enter the "Discount Mode". Depress key "#".
3. Depress key "B". The message center will display the current discount amount.

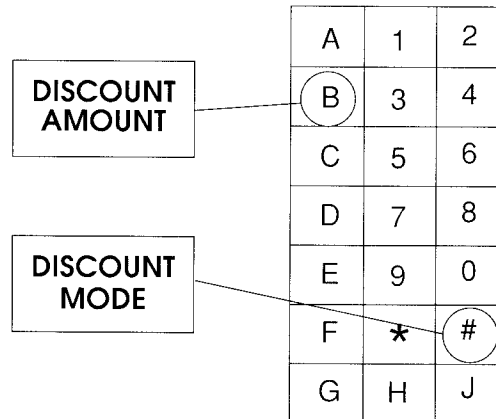

4. Enter the discount amount. Each digit is displayed as it is entered.

EXAMPLE: If you want to discount the items 25¢, enter 2 and 5. The message center will display \$00.25.

5. Depress key "#" to store the input in the controller's memory.

NOTE: Exit the "Discount Mode" by depressing the "Service Mode" button on the control board (See **Service Mode Section**). If no other service related function is required, or introduce a new service command.

HOW TO SET THE DISCOUNT ROW

When utilizing the "Discount Options" the items that will be discounted must be programmed into the controller. During the discount "ON" periods all items in the row selected (and all rows following) will be discounted during the time intervals that have been selected. When the discount is in effect, **"DISCOUNT AVAILABLE NOW"** will be displayed. When an item included in the discount is selected, the vend price will be reduced by the amount programmed. During the discount periods, the discount vend price can be verified by depressing the specific selection number. The discounted vend price will appear in the display.

CONTROLLER FUNCTIONS CONTINUED

HOW TO SET SELECT ROW OPTION

1. Place the controller in the "Service Mode" by depressing the Service Mode button located on the control board. (See **Service Mode Section**)
2. Depress key "#" on the front panel key pad. "DISCOUNT MODE" will appear in the display.
3. Depress key "C" on the front panel key pad. "SELECT ROW" will appear in the display.
4. Enter the "Alpha" character of the row the discount is to apply to. The row selected and all rows below the one selected will be included in the discount programs.

EXAMPLE: Press selection button "F". Rows "F", "G", "H" and "J" will be discounted.

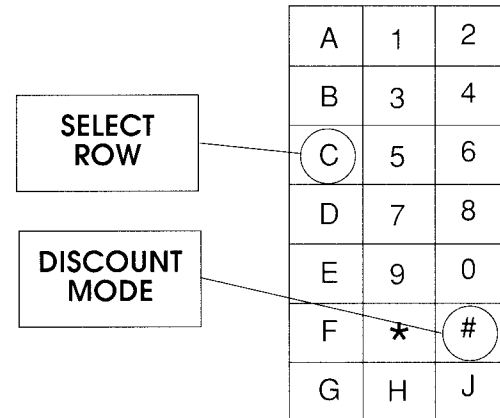

5. Depress key "#" located on the front panel key pad to store the input into the controller's memory.

NOTE: Exit the "Discount Mode" by depressing the "Service Mode" button on the control board, (See **Service Mode Section**). If no other service related function is required a new service, or introduce a new service command.

INSTALLATION CHECKLIST

1. All shipping brackets, packing material and tape have been removed from the vendor.
2. Vendor is properly located for access to power source outlet and vendor is level.
3. All components are installed on the vendor and are in good condition.
4. Service cord plug in receptacle is grounded or ground adaptor has been installed.
5. All vend prices are set correctly.
6. All selections have been properly loaded and all items in each selection correspond to the vend price and selection labels.
7. All options and features offered have been properly programmed into the controller. Refer to sections:
 - a) FORCE VEND ON/OFF
 - b) MULTI VEND ON/OFF
 - c) PROMO VEND ON/OFF
 - d) POINT OF SALES MESSAGE
 - e) SET TIME
 - f) DISCOUNT OPTIONS
 - g) LANGUAGE OPTIONS

To eliminate minor service problems caused by human error and to familiarize the owner/operator with the features and operation of the vendor, review the following with the owner and/or service personnel that will be responsible for the machine at the location.

1. Loading procedure and proper location and adjustments of spacers if they are included.
2. Price setting procedure for changing prices if necessary.
3. Basic diagnostic messages displayed and the meaning or cause.
4. How to enter and exit the "Service Mode".
5. Test vend procedure.
6. Removal of money from both the coin mechanism and validator.
7. Basic operation and function of the vendor.

COIN MECHANISM REMOVAL

To remove the coin mechanism follow the steps outlined below:

1. Turn the power switch off, located on power panel assembly. (See **Illustration #22**)

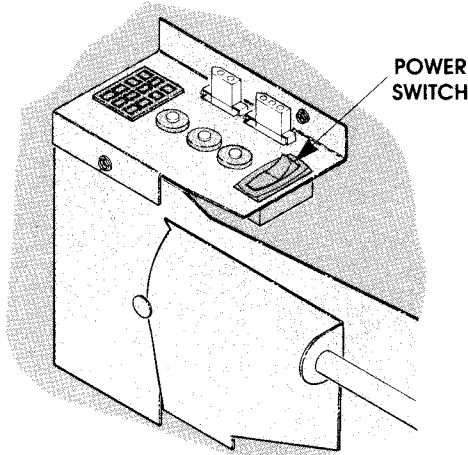

ILLUSTRATION #22

2. Disconnect the coin mechanism plug.
3. Release the acceptor latches. (See **Illustration #23**)
4. Tilt the acceptor toward you, raise up, and lift out. (See **Illustration #23**)
5. Loosen the retaining screw. Raise up on the coin mechanism to clear the key holes, tilt forward and lift out. (See **Illustration #23**)

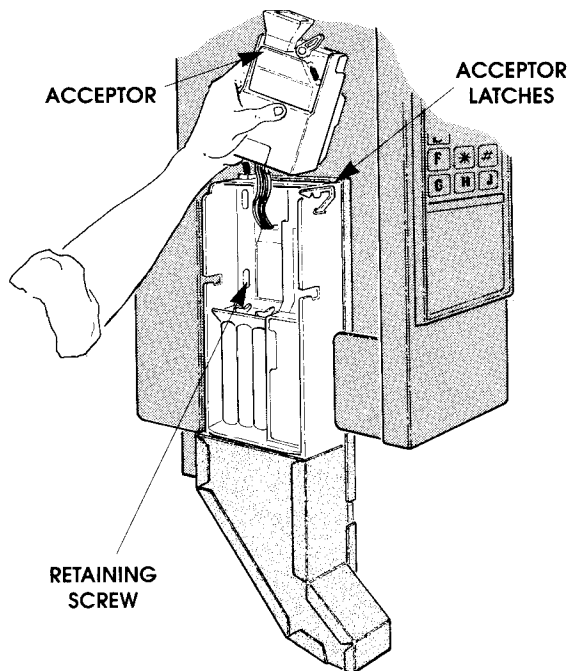

ILLUSTRATION #23

CONTROL BOARD REMOVAL

To remove the control board, follow the steps outlined below:

1. Turn the power switch off, located on the power panel assembly. (See **Illustration #22**)
2. Remove all the harnesses connected to the control board.
3. Remove the mounting screws. (See **Illustration #24**)
4. Remove the control board.

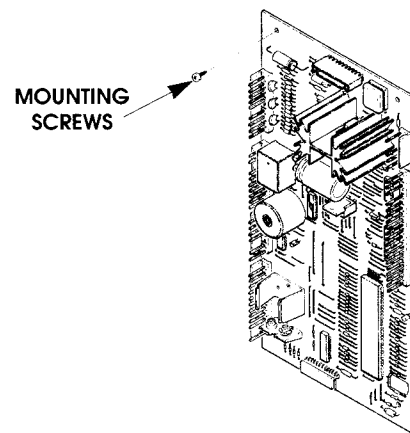

ILLUSTRATION #24

5. When replacing the control board See **Illustration #25** for location of harness plugs. Reverse **Steps 4 through 1**.

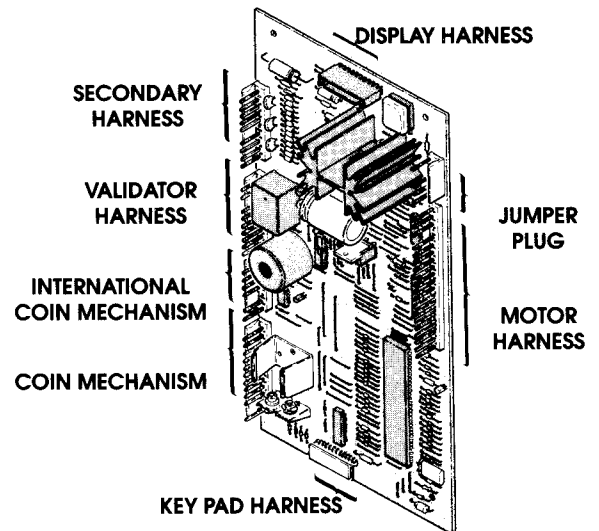

ILLUSTRATION #25

CAUTION: Handle the control board on its edges carefully in order not to induce any static charge.

COMPONENTS CONTINUED

DISPLAY BOARD REMOVAL

To remove the display, follow the steps outlined below:

1. Turn the power switch off, located on the power panel assembly. (See **Illustration #26**)

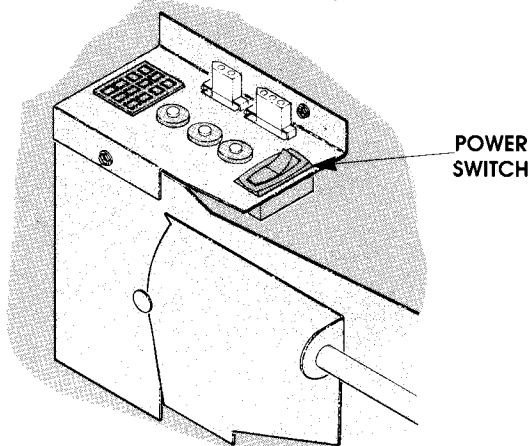

ILLUSTRATION #26

2. Disconnect the display harness from the control board.
3. Remove the lower mounting bracket and insulator attached to both the display and the validator or validator filler (which ever is used).
4. Remove the two (2) lower mounting screws from the display.
5. Lift the display out.

TRANSFORMER REMOVAL

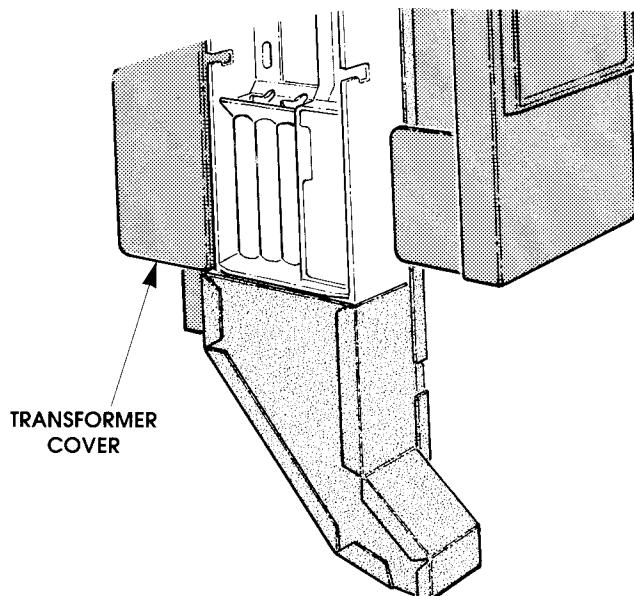

ILLUSTRATION #27

To remove the transformer box, follow the steps outlined below:

1. Turn the power switch off, located on the power panel assembly. (See **Illustration #26**)
2. Disconnect the power cord from the wall outlet.
3. Remove transformer cover by sliding it up and out.
4. Disconnect the cabinet power harness from the transformer. (See **Illustration #27**)
5. Remove the two (2) mounting screws.
6. Lift transformer away from control panel.

CONTROL PANEL REMOVAL

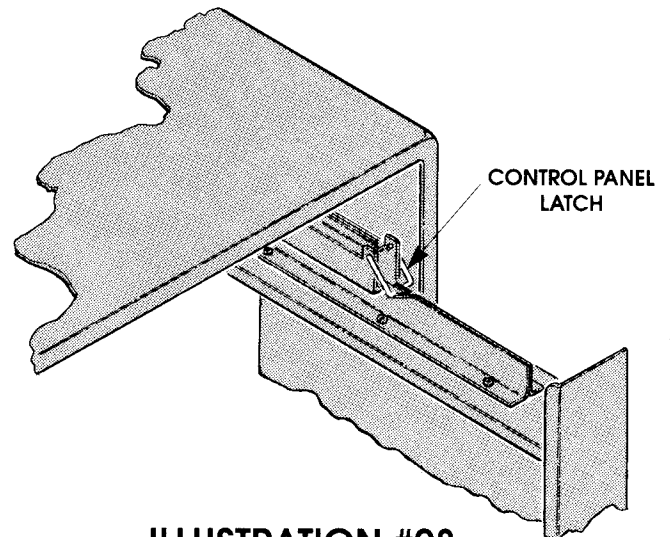

ILLUSTRATION #28

To remove the control panel, follow the steps outlined below:

1. Pull the control panel forward until the control panel latch meets the first of two catches. (See **Illustration #28**)
2. Turn the power switch off, located on the panel assembly. (See **Illustration #26**)
3. Disconnect the power cord from the wall outlet.
4. Disconnect the power harnesses from behind the transformer cover, (back of control panel assembly).
5. Lift the control panel latch past the 2nd catch.

NOTE: There are only two (2) catches on the control panel rail.

NOTE: Control panel is heavy. Be prepared for the weight when removing.

CARE & CLEANING

CAUTION: Always disconnect power source **BEFORE** cleaning.

CABINET INTERIOR

Wash with a mild detergent and water, rinse and dry thoroughly. Wax occasionally with a quality car wax. Plastic exterior parts may be cleaned with a quality plastic cleaner.

CABINET EXTERIOR

Wash with a mild detergent and water. Odors may be eliminated by including baking soda or ammonia in the cleaning solution.

The vend mechanisms **MUST** be kept clean. Any build-up of syrup deposits can cause these mechanisms to malfunction. Use soap and water with great care so as not to get water into the electrical components.

OPTIONAL ITEMS

The following kits are now available:

1200137-096 MICROWAVE WIDE PRODUCT KIT / 10CT.
(Container 6-5/8" x 5-1/4" x 1-5/8")

1200137-097 MICROWAVE WIDE PRODUCT KIT / 7 CT.
(Container 6-5/8" x 5-1/4" x 2")

1200137-098 MICROWAVE CUP PRODUCT KIT / 6 CT.

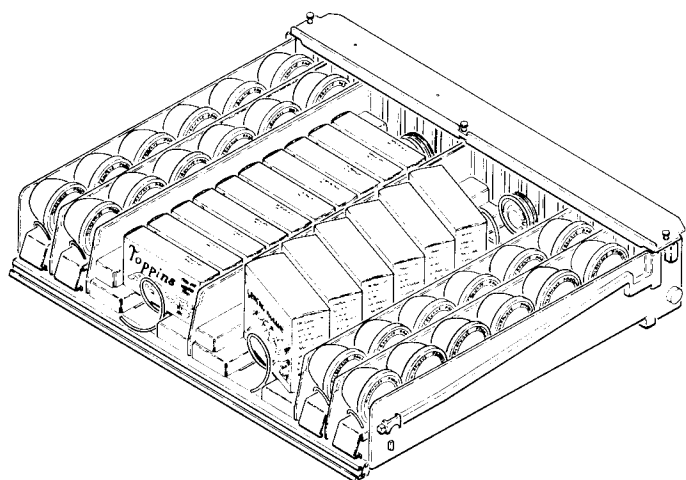

AUGER TYPE	PRODUCT SIZE			KIT PART NO.
	WIDTH	THICK	ITEMS	
"CANDY"	2-3/4	1-3/16	15	1200137-070
	2-3/4	15/16	18	1200137-071
	2-3/4	21/32	24	1200137-072
	2-3/4	1/2	30	1200137-073
	2-3/4	1-1/2	12	1200137-074
	2-3/4	2-1/32	9	1200137-075
	2-3/4	3-3/32	6	1200137-076
"SNACK"	5-1/2	1-13/16	10	1200137-077
	5-1/2	1-1/2	12	1200137-078
	5-1/2	1-3/16	15	1200137-079
	5-1/2	2-11/16	7	1200137-080
	5-1/2	2-5/8	8	1200137-081

KICK PANEL

P/N 1211131-003 3-WIDE

P/N 1211131-004 4-WIDE

P/N 1211131-005 5-WIDE

The kick panel is installed to cover the front legs of the machine. The kick panel hangs on brackets fastened to the front legs. To install this panel, proceed as follows:

1. Loosen the two inner most bolts, using a 7/16 wrench, holding the legs to the bottom of machine.
2. Using the two loosened bolts, position the bracket as shown in illustration and secure with bolts.
3. With bracket secured, slide the kick panel onto the bracket as shown in illustration.

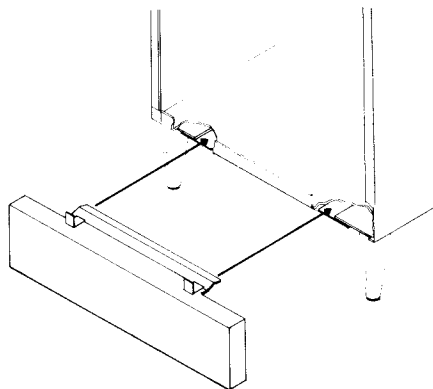

DOOR STOP

P/N 1210807

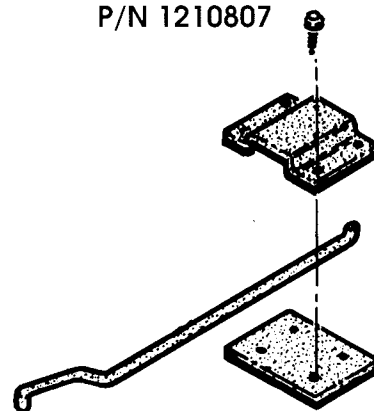

LOCK CYLINDER & 2 KEYS

P/N 4060330

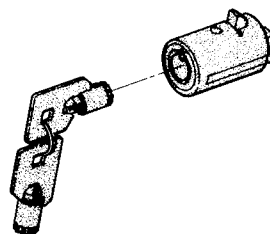

ELECTRICAL – TROUBLESHOOTING

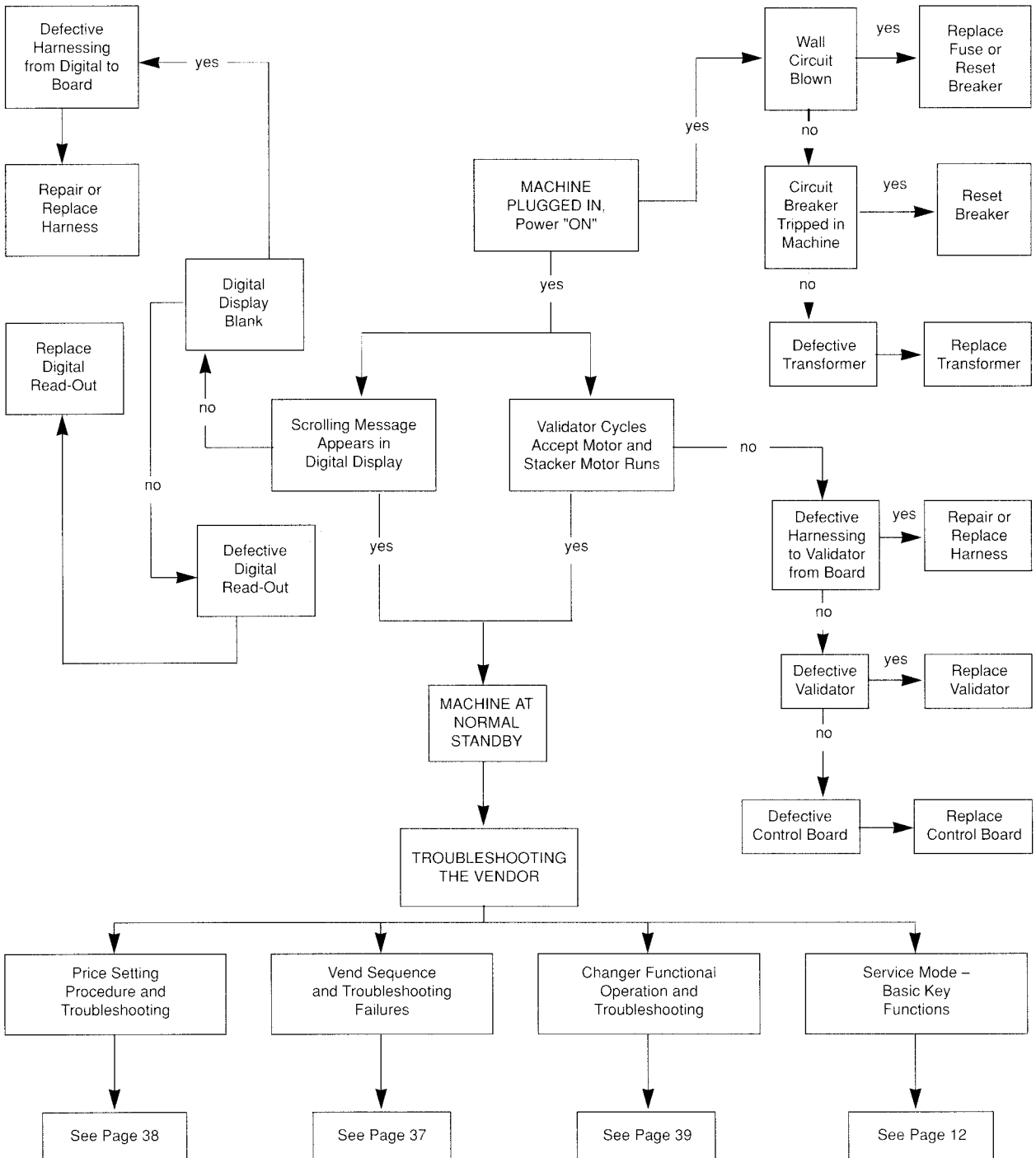

VEND SEQUENCE – TROUBLESHOOTING

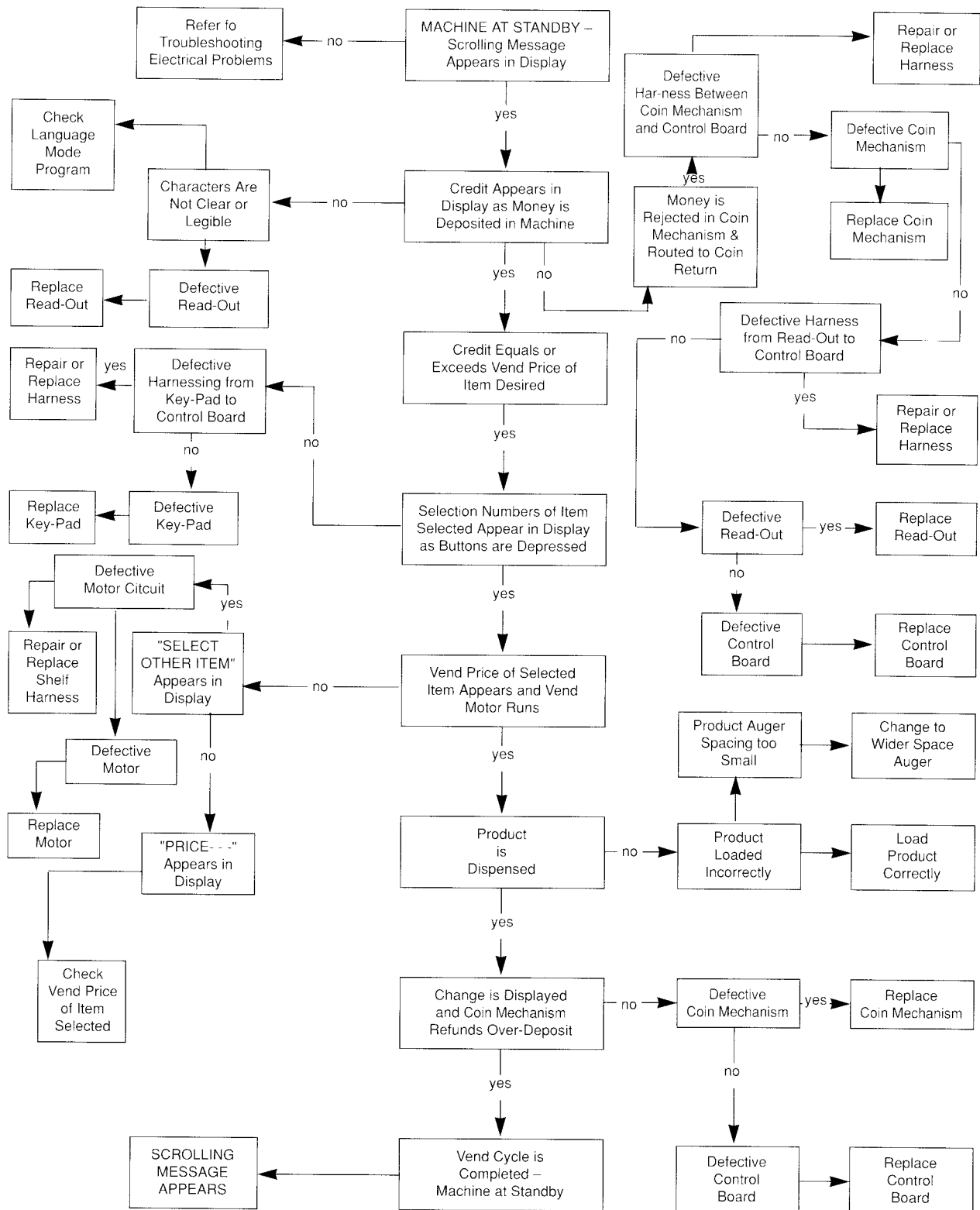

PRICE SETTING – TROUBLESHOOTING

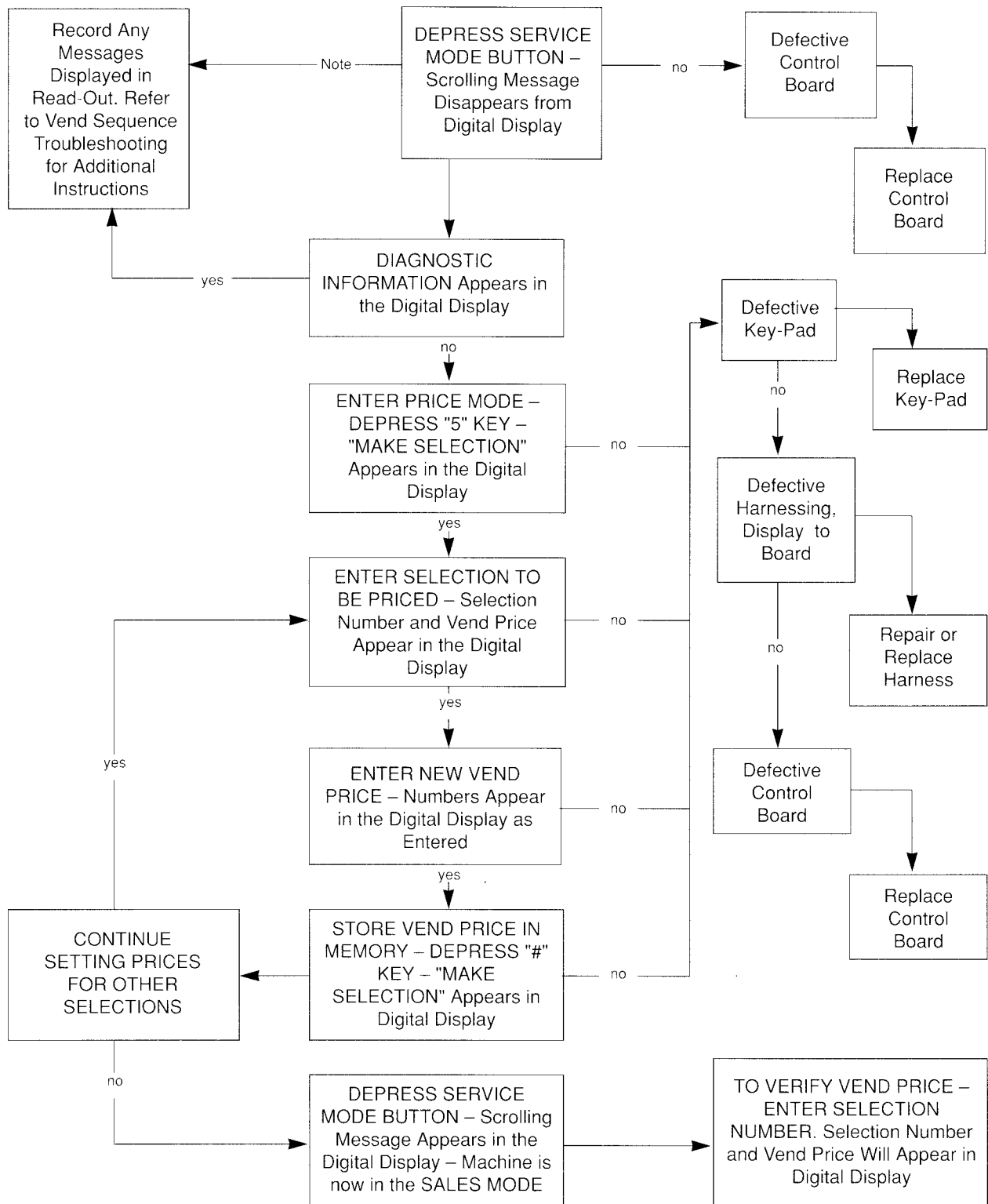

COIN MECHANISM – TROUBLESHOOTING

