

3000-S SERIES ELECTRONIC CHANGER OPERATION AND SERVICE MANUAL



 **coinco**®

CONTENTS

SECTION 1: GENERAL INFORMATION

Introduction	3
After Unpacking	3
Model Explanations & Features	3
Main Logic Board Assembly	4
Specifications	4

SECTION 2: INSTALLATION

Installing the Changer	5
Vend Price Switch Settings	5

SECTION 3: OPERATION

Coin Recognition	6
Coin Separation	6
Credit and Accumulation	8
Main Logic Board	8
Coin Tube Sensing	8
Change Payback	9
Exact Change Condition	9
Coin Payout	9
Dollar Credit	9
Escrow Until Vend/Changer Vendor Interface	9

SECTION 4: MAINTENANCE

Introduction	11
Routine Maintenance	11
Removing/Replacing Individual Module Assemblies	11
Cleaning	12
Clearing Coin Jams	14

SECTION 5: TUNING PROCEDURE

Introduction	15
Troubleshooting Guide	15
3000-S Interconnect	19
3000-S Logic Board Partial Layout	20

SECTION 6: PARTS LIST

Modular View	21
Changer Housing	22
Payout Assemblies	23
Logic Board Cover Assembly	24
Inventory Tube Assembly	24
Acceptor Front View	25
Acceptor Back View	26

SECTION 1: GENERAL INFORMATION

INTRODUCTION

This manual contains information on installing, operating and maintaining the Coinco **3000-S** series coin changers.

Familiarize yourself with this manual to obtain the best performance from you coin changer.

Refer to the model and serial number when calling for information. Both serial and model numbers can be found on the label on the side of the changer.

Example: Serial Number 1289008242 (week 12, year 89). The first and second digits indicate the week of manufacture and the third and fourth digits indicate the year of manufacture.

AFTER UNPACKING

After unpacking the unit, inspect if for any possible shipping damage. If the unit is damaged, notify the shipping company immediately. Only the co-signee (the person or company receiving the unit) can file a claim against the carrier for shipping damage. We recommend that you retain the original carton and packing materials to reuse if you need to transport or ship your changer in the future.

If the coin changer is being stored or used as a spare, always keep it in its shipping carton when not in use. This will keep it clean and offer the best protection for the unit.

MODEL EXPLANATIONS AND FEATURES

- Any vend price from 5¢ to \$3.15 in 5¢ increments can be selected using a single switch module.
- Heavy-duty D.C. payout solenoids provide fast, accurate payout.
- Provides fast and accurate electronic coin acceptance.
- Pays out to the last coin in the changer tube to provide the maximum usage of available coins.

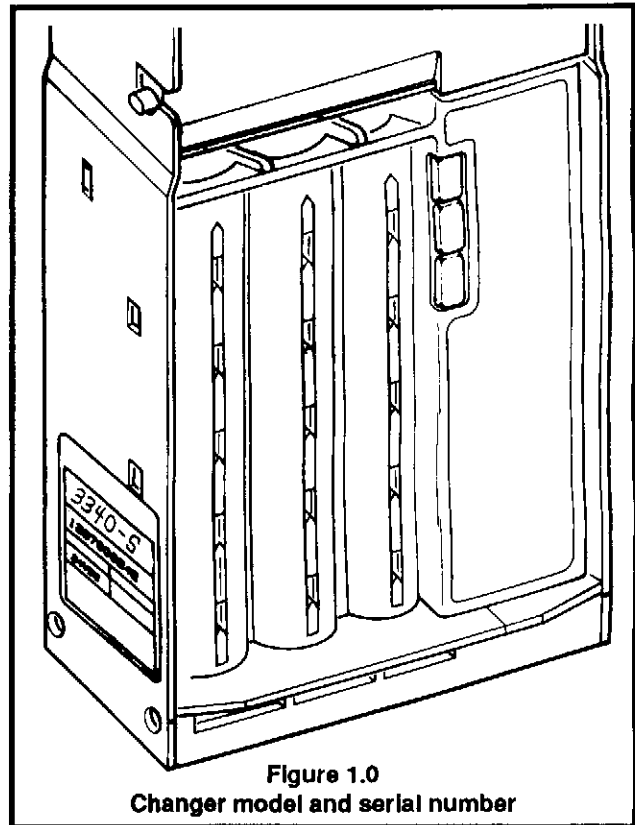

Figure 1.0
Changer model and serial number

SECTION 1: GENERAL INFORMATION

All 3000 Series Changers Accept U.S. Coins ONLY	Coins Accepted				Coins Paid Out			Coins Directed to Cash Box			Standard Dollar Bill Interface	Cash Accountability Output for 406735 Meter	Escrow to Vend
	Nickels	Dimes	Quarters	Dollars (SBA)	Nickels	Dimes	Quarters	Dimes	Quarters	Dollars (SBA)			
3100-S	●	●	●	●	●			●	●	●			●
3200-S	●	●	●	●	●	●			●	●			●
3240-S	●	●	●	●	●	●			●	●	●		●
3240-SC	●	●	●	●	●	●			●	●	●	●	●
3245-S	●	●	●	●	●		●	●		●	●		●
3245-SC	●	●	●	●	●		●	●		●	●	●	●
3340-S	●	●	●	●	●	●	●			●	●		●
3340-SC	●	●	●	●	●	●	●			●	●	●	●

MAIN LOGIC BOARD ASSEMBLY

The main logic board contains the microprocessor which controls all the functions of the coin changer based on informations from other changer parts as well as the vending machine.

Also contained on the main logic board is the power supply which receives the primary AC voltage from the vendor. From there, the primary AC voltage goes two places: to be rectified to a DC primary voltage to operate the coin payout dispensing solenoids, and to the changer transformer where it is stepped down to an 18 VAC voltage. This 18 VAC is routed back to the control board where it is rectified and filtered for logic board operation.

SPECIFICATIONS

POWER REQUIREMENTS

95 to 130 VAC 60 HZ

VEND PRICE RANGE

5¢ TO \$3.15

OPERATING TEMPERATURE

0 degrees F to 160 degrees F
-18 degrees C to 65 degrees C

STORAGE TEMPERATURE

-22 degrees F to 160 degrees F
-30 degrees C to 72 degrees C

RELATIVE HUMIDITY

20% to 98% Noncondensing

PHYSICAL DIMENSIONS

Height: 14.81 inches high (base to top of coin return lever)

Width: 5.28 inches in width (acceptor latch to acceptor latch)

Depth: 2.86 inches (gate closed)

PHYSICAL WEIGHT IN SHIPPING CARTON

5.6 pounds

COIN TUBE CAPACITY

	\$.05 Tube	\$.10 Tube	\$.25 Tube
Low Sensor Level	7	9	7
Full Sensor Level	78	113	77
Hand Load Level	86	125	95

SECTION 2: INSTALLATION

INSTALLING THE COIN CHANGER

See Figure 2.0

1. Remove power from vendor.
2. Remove the acceptor from the changer by releasing acceptor latches and pulling the top of the acceptor forward, away from changer. Unplug ribbon cable from changer. Free lower acceptor studs from changer housing. With the acceptor removed, set key holes in back of changer housing over mounting screw in the vendor. Tighten snugly.
3. Set desired changer options (See Vend Price Switch Settings.)
4. Replace the acceptor by inserting bottom acceptor studs into changer housing guides. Plug the acceptor ribbon cable into the changer. Press top of acceptor into changer housing until top acceptor studs lock into changer's acceptor latches.
5. Connect changer to desired options, if any. Plug changer into eight-pin vendor socket.
6. Load coin tubes making sure all coins lie flat.
7. Apply power to vendor.
8. Test changer with a variety of coins to insure proper operation.

NOTE: SAVE THE COIN CHANGER CARTON.
Always store coin changer in its shipping carton when not in use. This will keep the unit clean and protected.

VEND PRICE SWITCH SETTINGS

See Figure 2.0

1. Unplug the coin changer.
2. Remove the acceptor.
3. Located in the upper portion of the changer is a single switch module with 6 rocker switches. When the top of the rocker switch is pushed in, it is in the ON position. The switches correspond as follows:
 - 1= 5¢
 - 2= 10¢
 - 3= 20¢
 - 4= 40¢
 - 5= 80¢
 - 6= \$1.60
4. The vend price is set by adding the value of switches 1-6, which are in the ON position. Example: Switches 1, 3 and 4 in the ON position = 65¢ vend price.
5. Set switches 1-6 to desired vend price. Make sure vend price set on changer corresponds to vend price indicated on front of vendor.

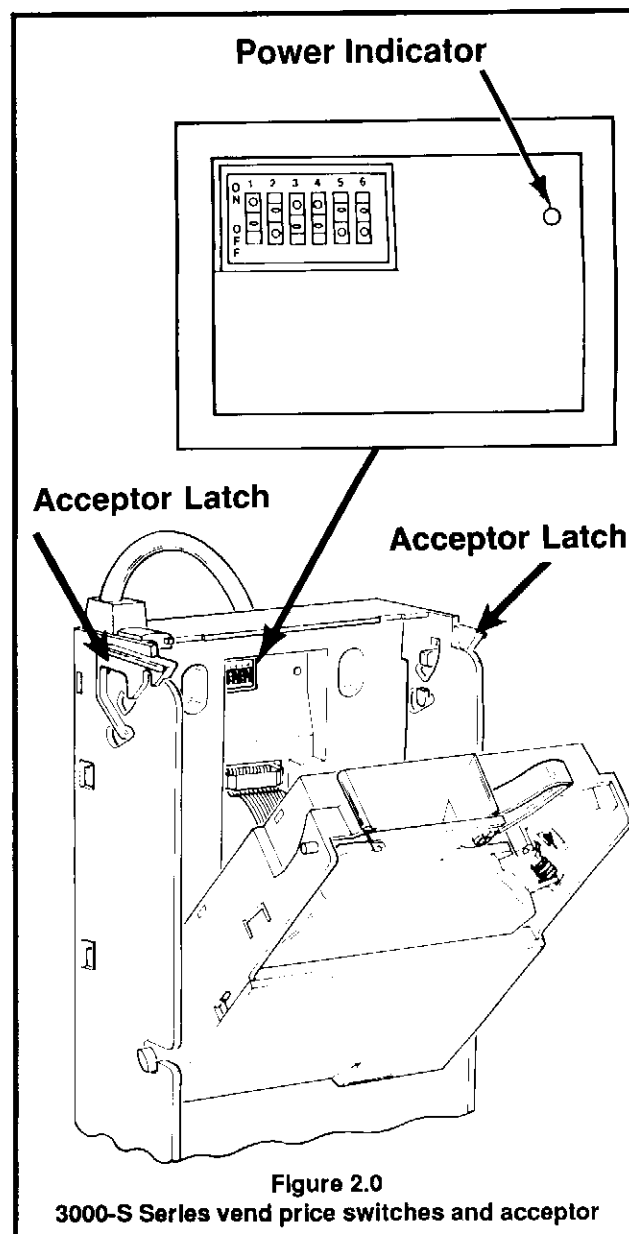

Figure 2.0
3000-S Series vend price switches and acceptor

SECTION 3: OPERATION

COIN RECOGNITION

See Figure 3.0

As a coin enters the changer through the acceptor funnel, its impact is absorbed by a white ceramic rail which debounces the coin and allows it to continue down the coin rail at a smooth and steady speed. As a coin rolls down the rail, it passes between two magnetic coils which measure the size and magnetic properties of the coin. These measurements are used to determine if the coin is valid and the value of the coin.

COIN SEPARATION

See Figure 3.0

After the coin's validity has been determined, the coin rolls off the end of the coin rail and enters the separator section of the acceptor. The UPPER (coin tube) gate and the LOWER (cash box) gate are opened and closed by their respective solenoids. These solenoids are energized and de-energized by an electrical signal from the acceptor logic board based on the following criteria.

- the validity of the coin
- the denomination of the coin
- the status (full or empty) of the appropriate coin tube

The positions of these two gates cause the coin to be routed to one of three places: the appropriate changer coin tube, the vendor cash box, or if the coin is rejected, the vendor coin return cup.

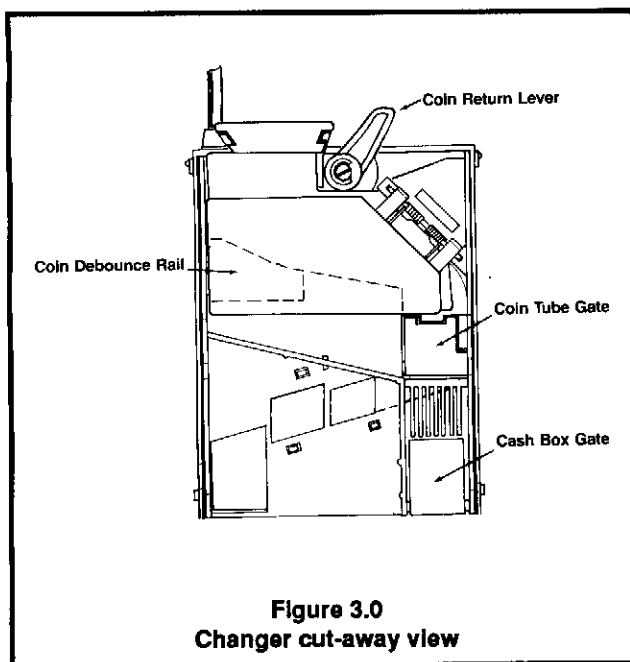

Rejected Coin

See Figure 3.1

If a coin is rejected for any reason, both the UPPER (coin tube) gate and the LOWER (cash box) gate will remain closed. All rejected coins will drop into the vendor coin return cup via the coin changer coin return chute.

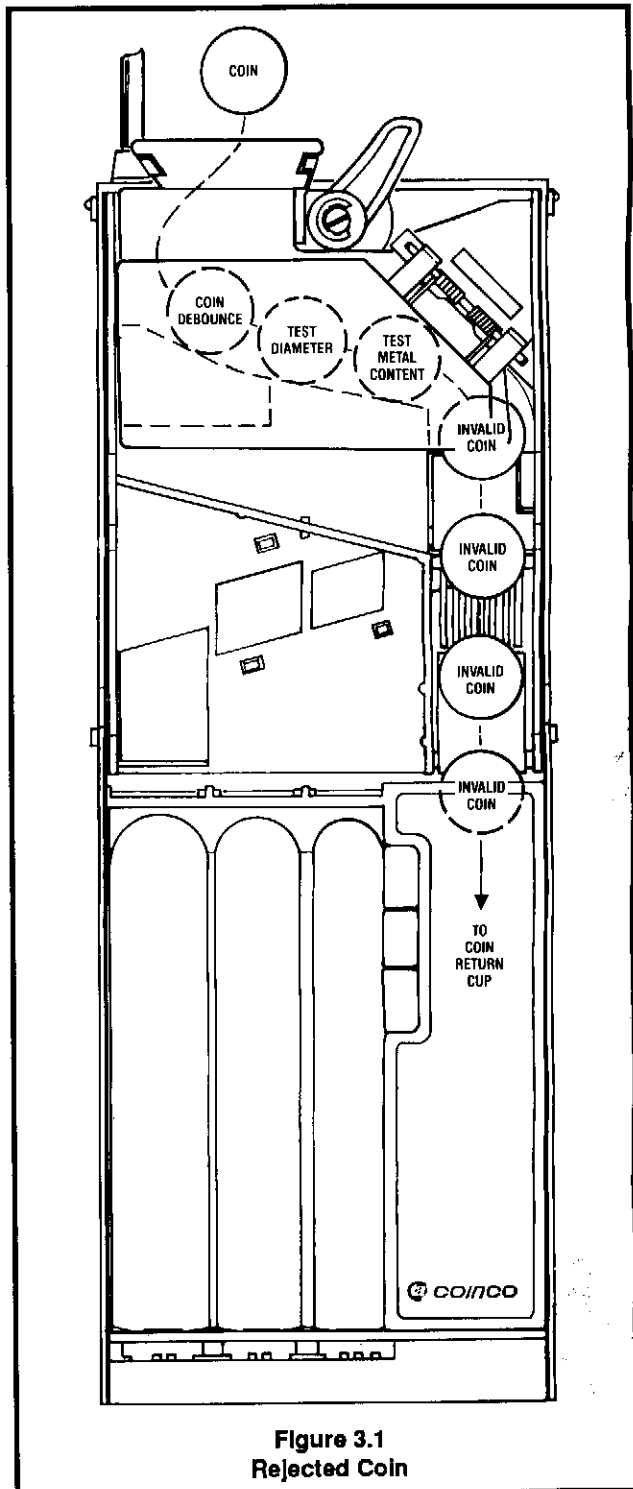

SECTION 3: OPERATION

Accepted Coin

See Figures 3.2 and 3.3

An accepted coin is diverted in one of two directions depending on the full sensor in each coin tube. If the full coin tube sensor is blocked (tube full) for the corresponding coin, the lower (cash box) solenoid energizes, sending that coin to the cash box. If the full tube sensor is not blocked (tube not full) for the

corresponding coin, the upper (coin tube) solenoid will energize, directing that coin to the separator rail where it is diverted to the correct coin tube. Dollar coins are diverted directly to the cash box via the lower (cash box) solenoid.

NOTE: If you wish to reject dollar coins, this may be done by removing CR15 from the main logic board (See Figure 3.4).

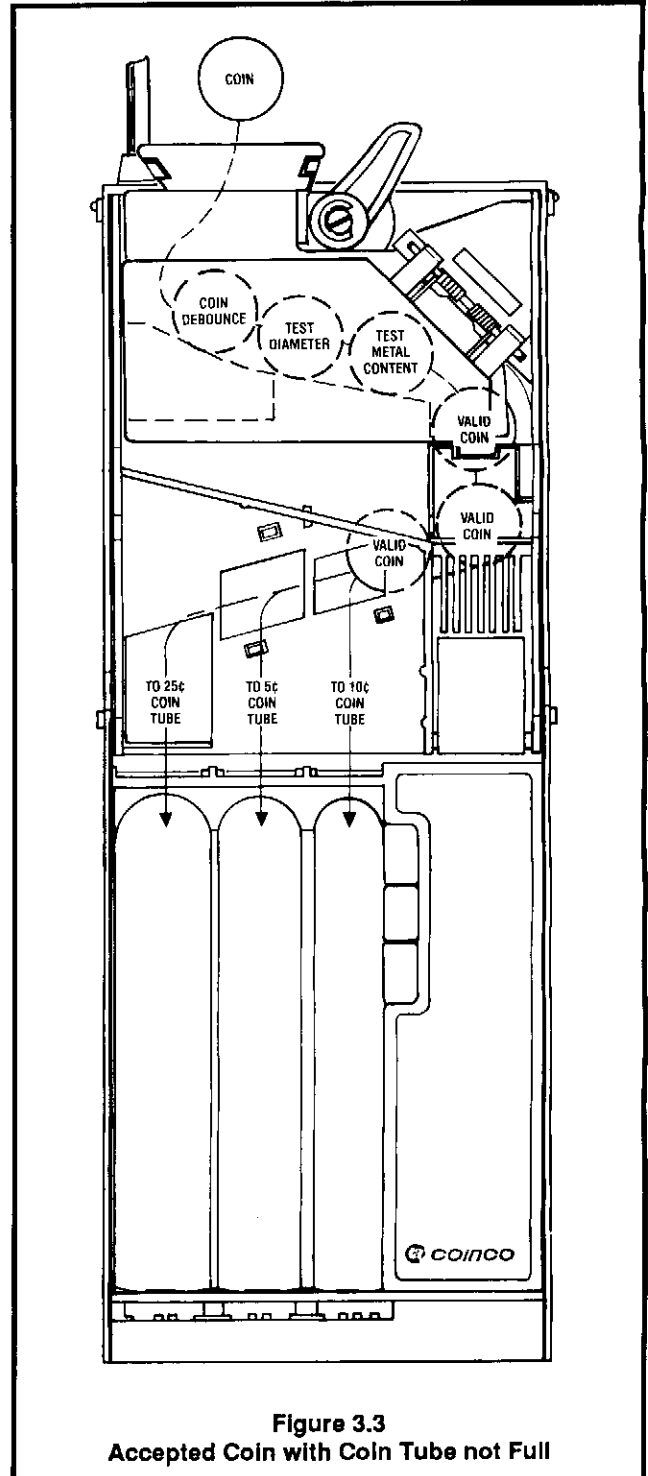
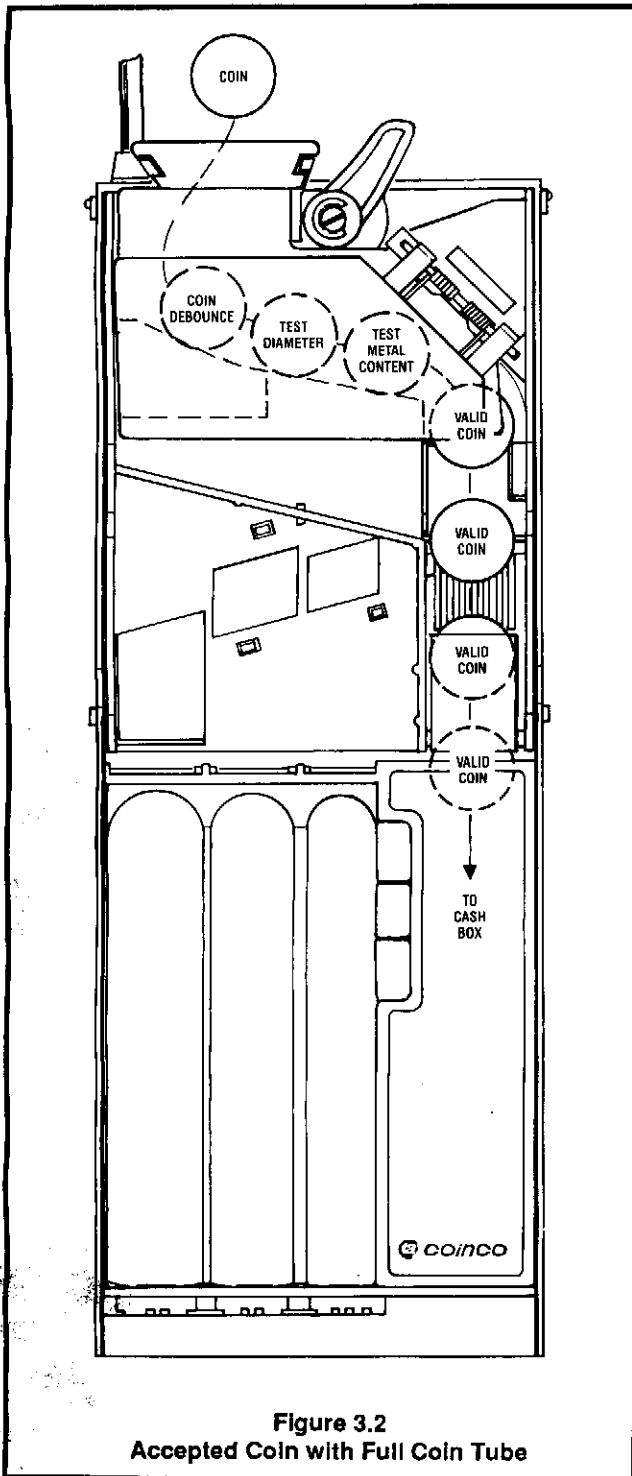

SECTION 3: OPERATION

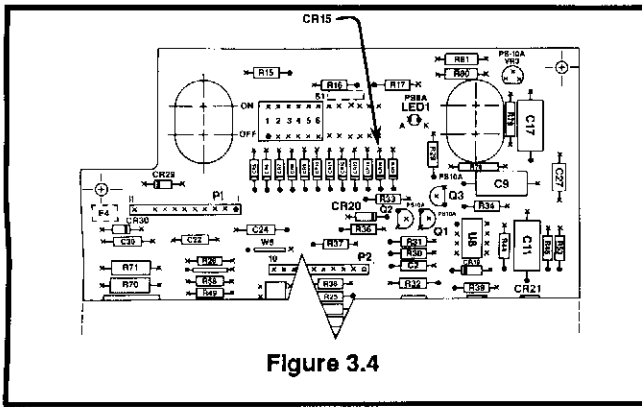

Figure 3.4

The full tube sensors in each coin tube continually report the (full/not full) status to the coin changer's microprocessor. The information is then used to determine the placement of the next accepted coin. This information controls the action of the acceptor coin tube and cash box gates.

CREDIT AND ACCUMULATION

See Figure 3.5

There are two sensors, one in the separation section of the acceptor and one in the cash box path of the acceptor. As coins pass either one of these sensors, the changer sends credit information to the vendor electronic controller board where the coin credit is accumulated.

MAIN LOGIC BOARD

The main logic board is responsible for all logic functions of the changer. It receives information from other changer modules as well as the vending machine, and based on this information, controls the operation of the changer.

The main logic board also contains the changer power supply. It receives the incoming AC voltage from the vendor and does the following: First, it is rectified to a DC voltage for the payout solenoids. Second, it is routed to the transformer's primary where it is reduced to 18 VAC. This 18 VAC is routed back to the logic board where it is rectified and filtered to the operating DC voltage.

COIN TUBE SENSING

See Figure 3.6

The low tube sensors in each coin tube continually report the (blocked/not blocked) coin level to the microprocessor. This information is used to determine the availability of change for:

- Change Payback
- Escrow
- Exact Change Condition

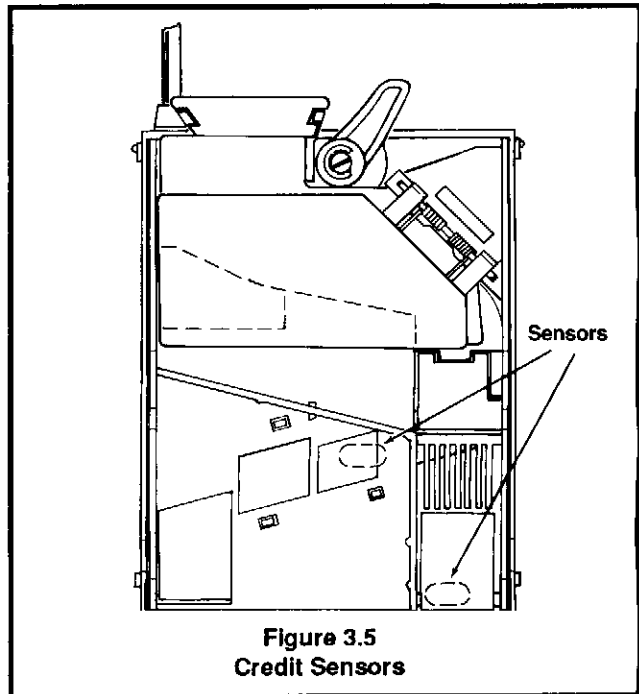

Figure 3.5
Credit Sensors

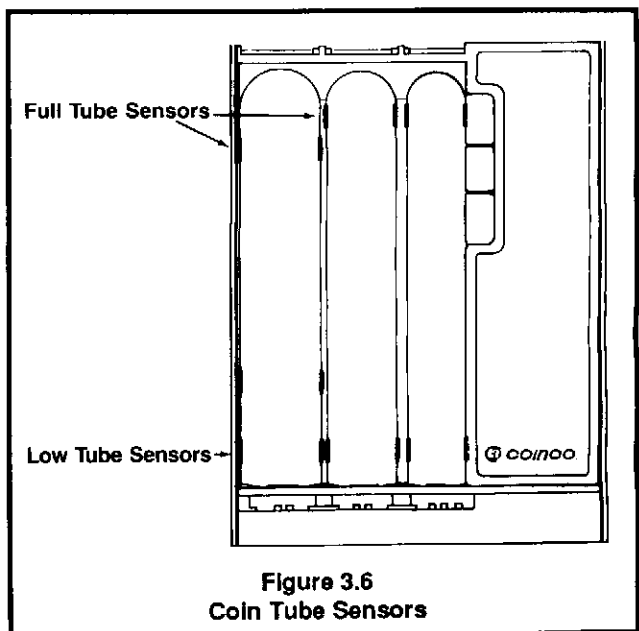

Figure 3.6
Coin Tube Sensors

SECTION 3: OPERATION

EXAMPLE: If the quarter coin tube is full (full sensors blocked by coins), the acceptor coin tube gate will remain closed and the cash box gate will open each time a quarter is accepted, routing all quarters to the vendor cash box via the changer coin chute. After one or more quarters is paid out as change, leaving the full sensor exposed (quarter tube not full), the accepted coin tube gate will open each time a quarter is accepted, routing quarters to the changer coin tube until it is full again.

CHANGE PAYBACK

The low tube sensors report whether coins are available for payback so payout can be made in the fewest coins available.

EXACT CHANGE CONDITION

The microprocessor is constantly looking at the change status. If correct change cannot be made, the changer rejects the last coin deposited, which would have resulted in an over insertion. At this time, the correct change light flashes on and off in one second intervals for eight seconds, during which time the escrow lever may be depressed for a full refund, the correct change may be inserted or the same coin which was rejected may be reinserted. (However, no change payout will be attempted under this condition.)

On units with a dollar bill input, if correct change cannot be made for a dollar bill, the correct change light will be lit continuously, inhibiting the bill validator.

COIN PAYOUT

The payout assembly pays out coins using solenoid-operated slides. Coins are paid out for change payout, escrow return and manual inventory of the coin tubes.

When a solenoid energizes, the upward motion of its plunger compresses a spring and draws the solenoid lever, which in turn pushes a payout slide forward. This loads the coin for payout. When the solenoid de-energizes, the spring force returns the plunger to its de-energized state, which returns the solenoid lever, which returns the payout slide, which in turn pays out a coin. Payout rate is two coins per second.

Change Payout: When the amount of credit exceeds the vend price, a payout will be made in the least number of available coins. (See Exact Change Condition)

Escrow Return: When a request for escrow is made, the changer will return the amount credited in the least number of available coins. Under exact change conditions, nickels, dimes and quarters may be returned coin for coin.

Manual Inventory of Coins: Operating the manual inventory switches empties the changer coin tubes. The inventory switches are red for quarters, white for nickels and blue for dimes, and are located on the front of the inventory tube assembly. Only one inventory switch will operate at a time.

DOLLAR CREDIT

All 3000-S Series changers inhibit the escrow of the credit from a dollar coin or input from a dollar bill validator. Credit will be retained if the escrow lever is depressed. At this time, vend price must be met and a selection made.

ESCROW UNTIL VEND CHANGER/VENDOR INTERFACE

See Figures 3.7 & 3.8

As coins are inserted, the changer's logic board compares the accumulated credit to the vend price. When adequate credit is reached, the changer's logic board activates the changer's vend relay for 250 milliseconds. This energizes the vendor's credit relay, cancels the changer's credit and initiates the change making cycle if required.

The energizing and latching of the vendor's credit relay removes power from Jones plug line six, which inhibits the acceptance of coins. The changer's vend relay's N/C contact connects the AC hot line to the N/O contact of the vendor's credit relay, which connects the AC hot line to the selection switches.

When a selection switch is activated, the vendor's vend motor begins to run. The vend motor mechanically activates a motor carrier switch which holds power to the vend motor until the motor returns to its home position and de-activates the vend relay of the vendor. This returns power to Jones plug line six enabling the acceptance of coins.

SECTION 3: OPERATION

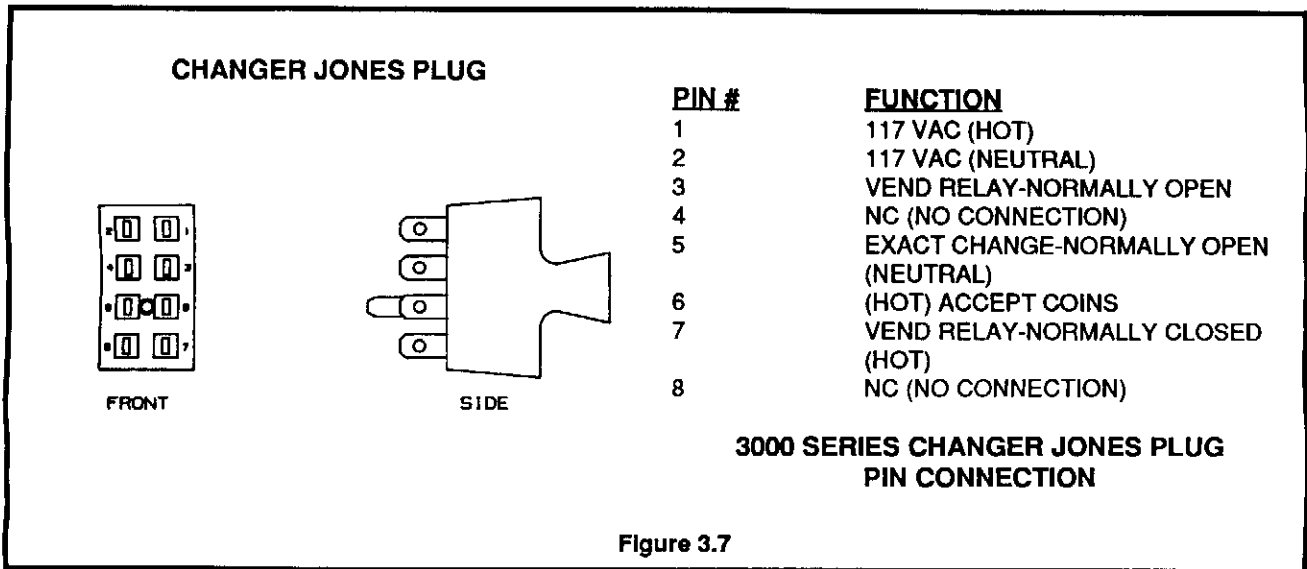
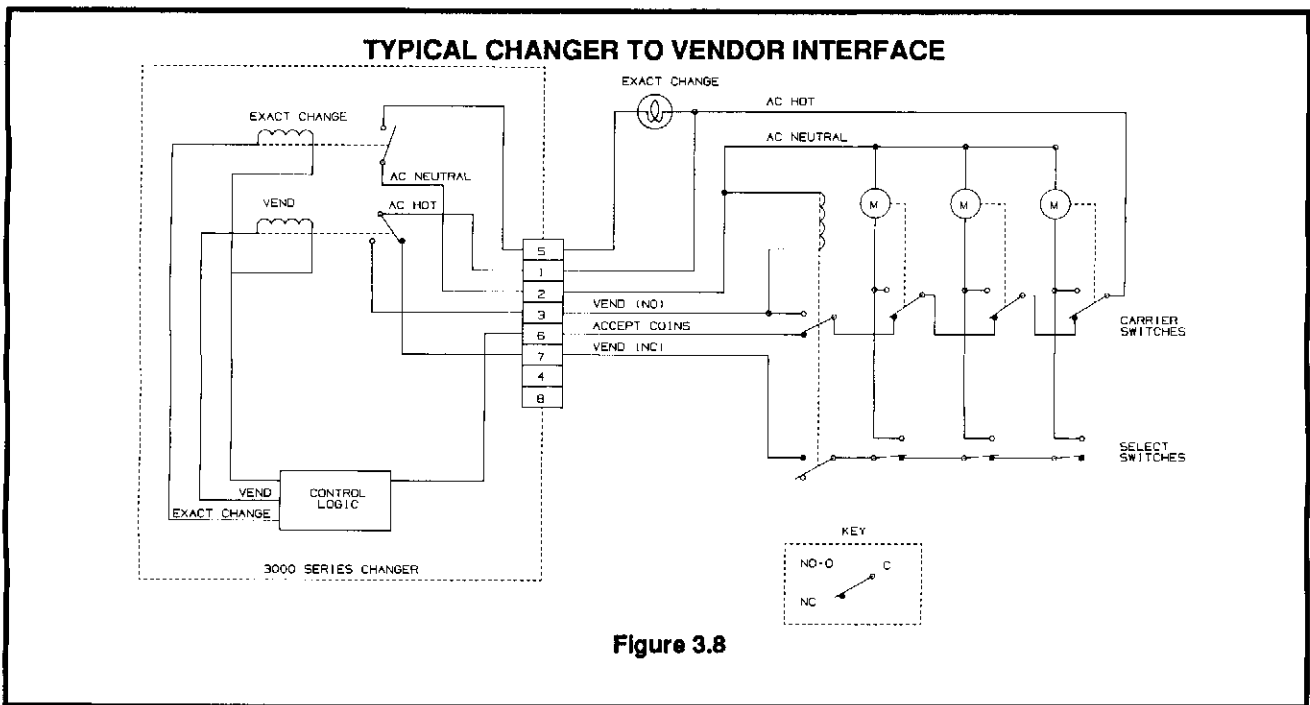

Figure 3.7



ROUTINE MAINTENANCE

Routine maintenance will improve performance and extend the working life of the 3000 series changer and reduce the need for more involved repairs. Frequency of routine maintenance will depend on environment and number of transactions.

The coin changer should be kept in its original shipping carton when not in use. This will keep the changer clean and afford the best protection for the unit.

REMOVING/REPLACING INDIVIDUAL MODULE ASSEMBLIES

Modular assembly replacement provides the basis of all 3000 series changer repair. Instructions for removing and replacing modules are provided below. These modules should be removed in the following sequence:

Acceptor

To remove the acceptor, raise the two acceptor latches and pull the top of acceptor forward and away from the changer housing. Unplug acceptor ribbon cable from main logic board. Raise acceptor and pull outward until the acceptor clears the housing slots.

Coin Tube and Tube Sensor Assembly

See Figures 4.0 & 4.1

Remove logic board cover by spreading the changer housing slightly and pulling up on board cover. Unplug tube sensor ribbon cable from logic board. Spread the lower part of the housing slightly and pull out on tube assembly. To separate the coin tube assembly from the tube sensor board assembly, place the assembly face down. While freeing the four locking tabs, pull up on tube sensor board. Be careful not to damage sensors on logic board.

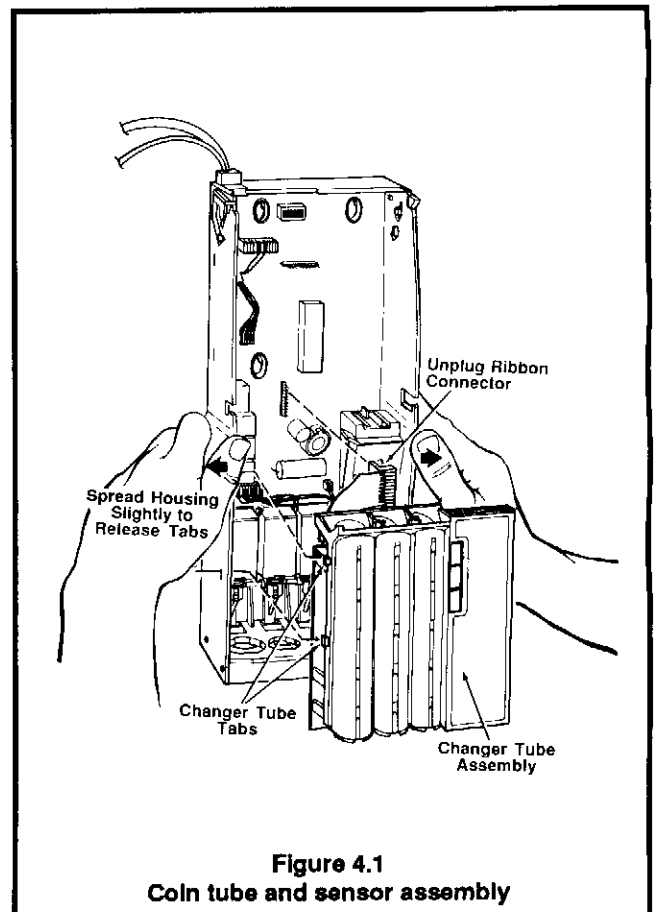
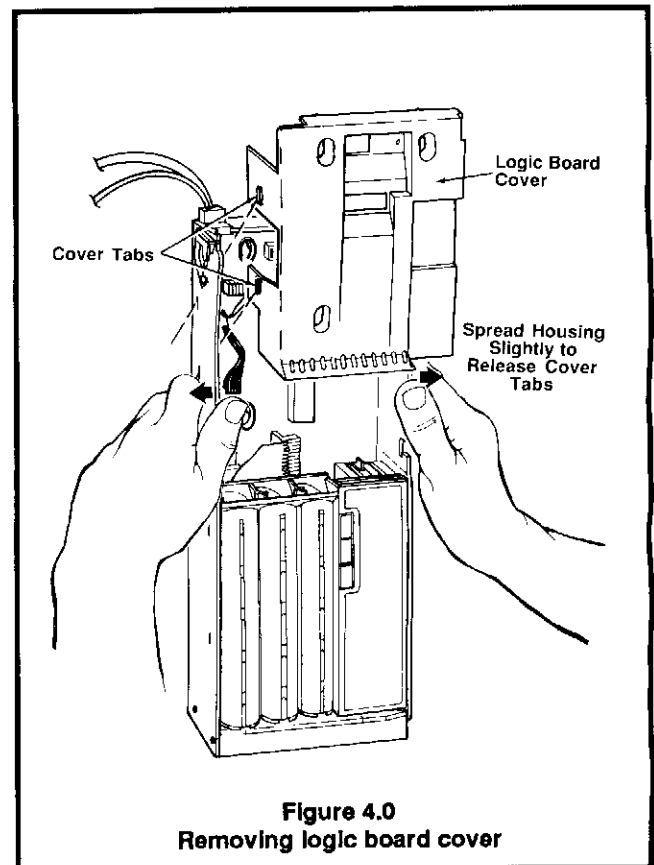

SECTION 4: MAINTENANCE

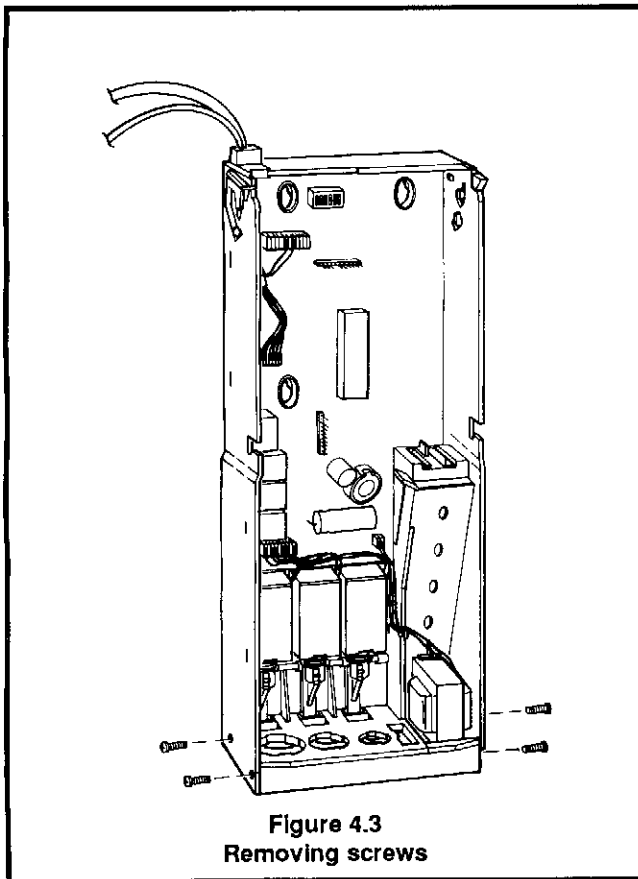
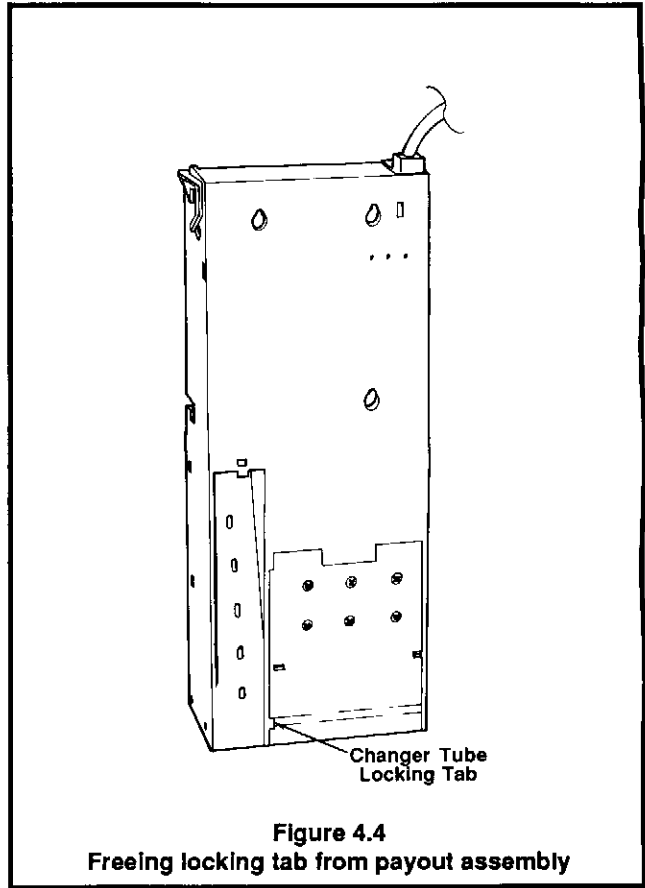
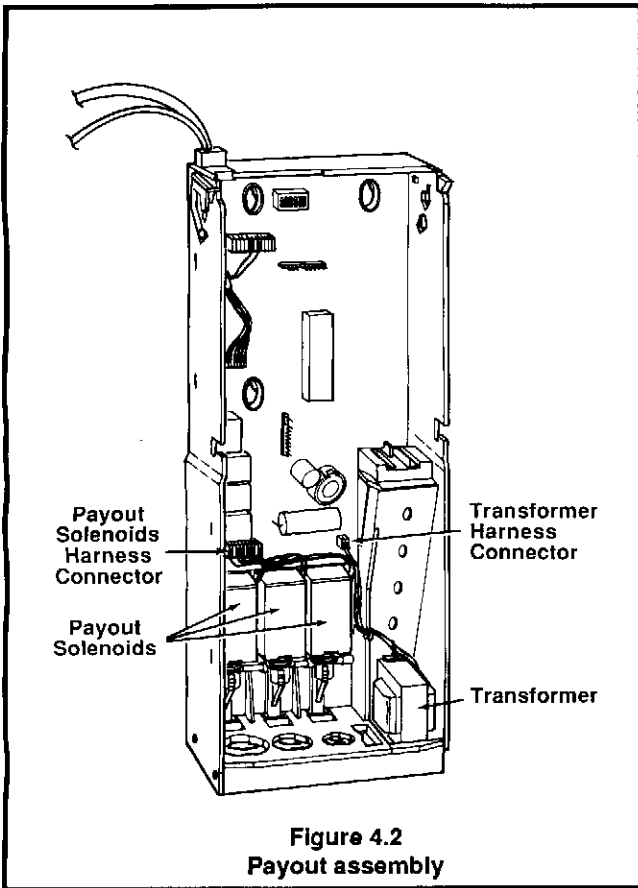

Main Logic Board Assembly

See Figure 4.2

Unplug primary and secondary windings of the transformers, payout solenoids and the main harness assembly from logic board. Lift top of logic board and slide upward, then lift board out of housing.

Payout Assembly

See Figures 4.2, 4.3 & 4.4

Unplug transformer and payout solenoids from logic board. Remove the four Phillips head screws from the housing side panels. From the back of the changer, free the locking tab of the changer housing from the payout assembly. Remove payout assembly.

CLEANING

The main material used in the manufacture of the 3000-S series changer is a high-quality industrial grade plastic, which should only be cleaned with a warm water and mild detergent solution.

SECTION 4: MAINTENANCE

CAUTION:

- NEVER SUBMERGE CHANGERS IN WATER.
- DO NOT USE PETROLEUM SOLVENTS, STEEL WOOL, SCOURING PADS OR A METAL BRUSH FOR CLEANING.
- DO NOT SPRAY ANY PART OF CHANGER WITH ANY TYPE OF LUBRICANT.

Since all coins share a common coin ramp, heavy usage or a dirty environment can result in dirt build-up. To clean the coin ramp, lift the acceptor gate upward and diagonally to the right. Hold gate firmly to prevent it from snapping back. Wipe the exposed coin ramp and inner surface with a damp cloth. For excessively dirty units, use a damp cloth with a mild detergent.

NOTE: Do not submerge in water.

For detailed cleaning of the acceptor, remove the front cover by pulling out and down on the front cover. Now remove the back cover by pushing in on two locking tabs on the side of the acceptor. To remove the coin sorting rail, desolder the four wires to the two sensors from the logic board to prevent damaging them. (Changers manufactured after June 1989 do not require desoldering but sensors may be removed by carefully prying up on sensors with a small flat-tipped screwdriver. **NOTE:** Care must be taken to prevent damaging wires of sensors.)

From the front of the acceptor, in area exposed by removing the front cover, locate the three locking tabs which secure the sorting rail. Using a small straight tip screwdriver, free the three locking tabs and remove sorting rail. See Figure 4.5.

Disassembling Payout Base for Cleaning

See Figures 4.6 & 4.7

Remove the four Phillips head screws from the bottom plate. Remove bottom plate and individual slides. Clean parts with mild detergent and hot water as desired. **DO NOT SUBMERGE SOLENOIDS OR TRANSFORMER IN WATER.**

Replace slides making sure part numbers face up into changer. With the slides correctly seated on plunger tabs, reinstall the bottom plate, securing with bottom screws. Reinstall payout module into changer, securing with side screws.

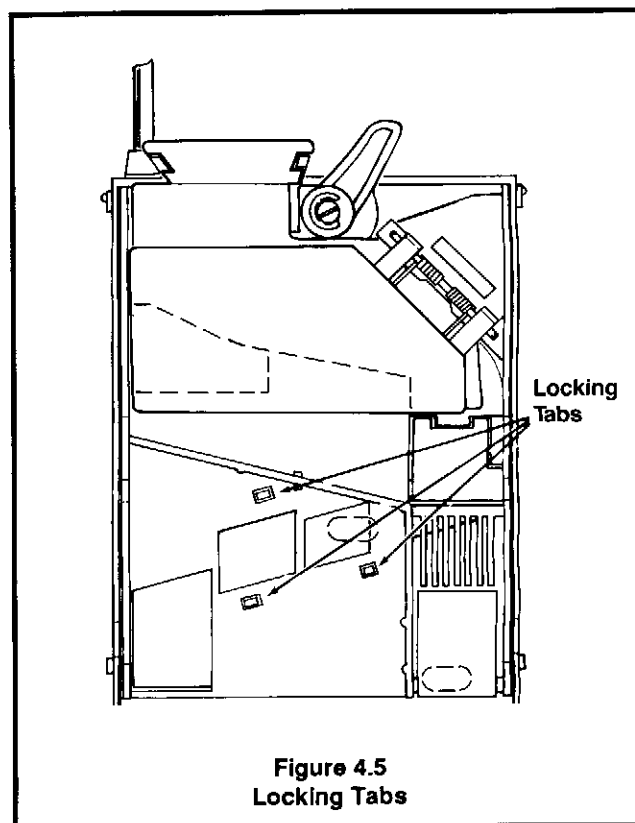

Figure 4.5
Locking Tabs

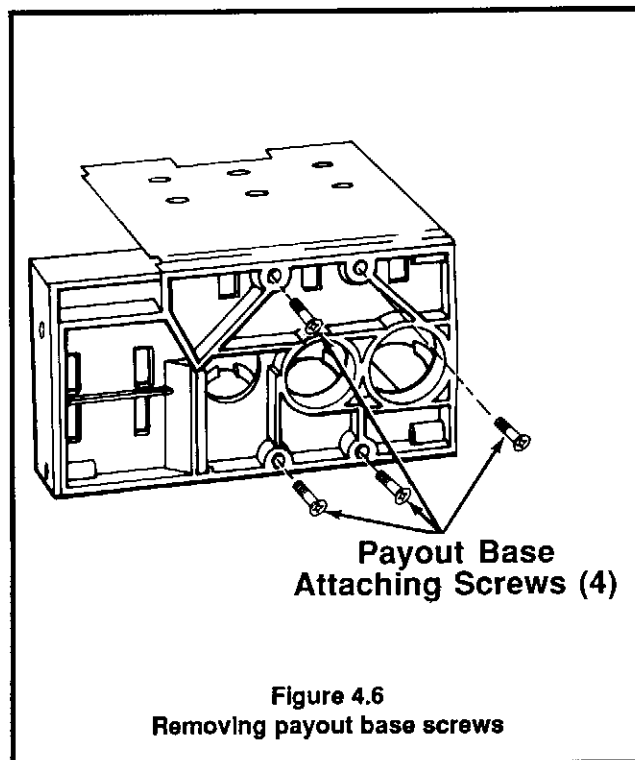
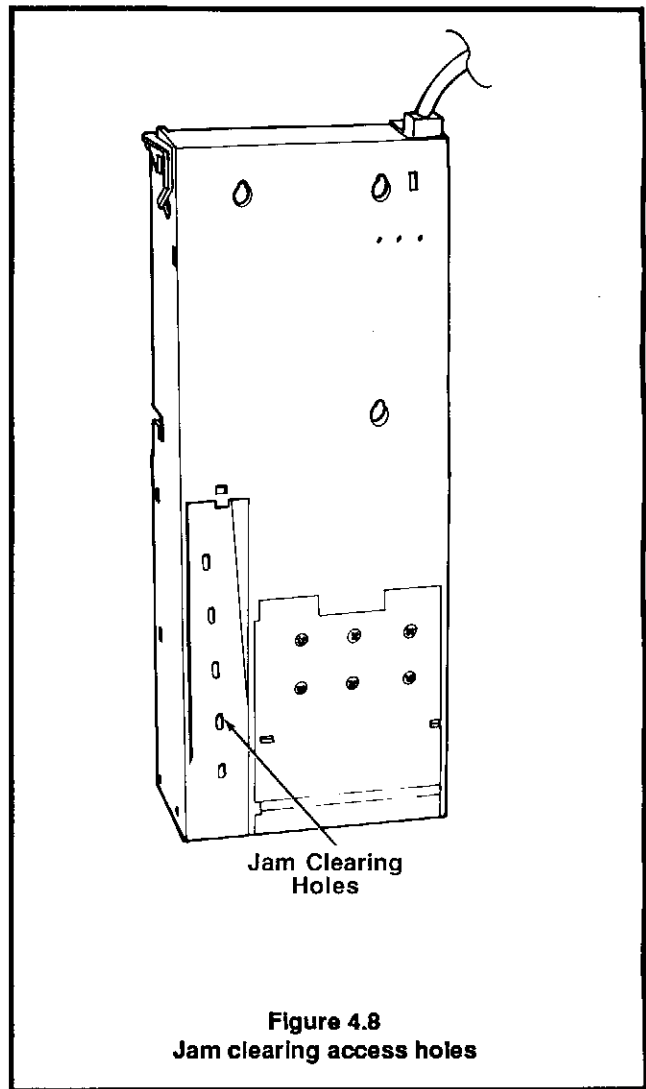
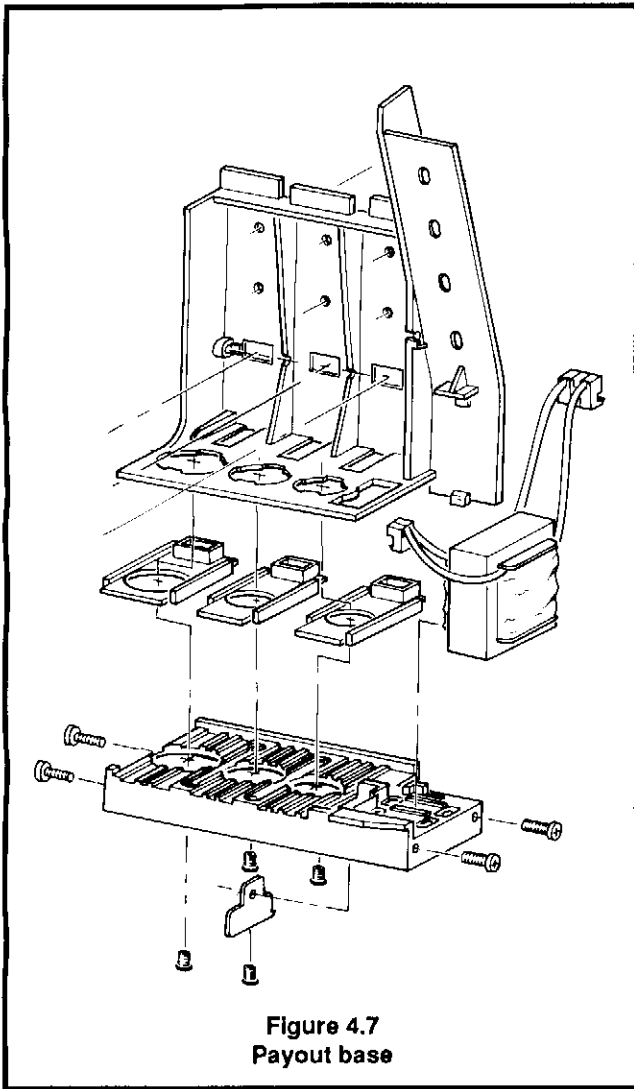

Figure 4.6
Removing payout base screws

SECTION 4: TROUBLESHOOTING



CLEARING COIN JAMS

Should a coin jam occur in the cash box chute area, use the following steps to help dislodge coins:

1. Remove change from vendor.
2. Keeping changer in an upright position, insert a narrow screwdriver into cash box chute or reject chute from bottom of changer to relieve jam. Access holes are also provided at the rear of the changer housing to help relieve coin jam.

CAUTION: Excessive screwdriver pressure or twisting can cause permanent damage to the coin changer.

SECTION 5: TROUBLESHOOTING

INTRODUCTION

The Troubleshooting Guide on the following pages is intended to help locate problems within the coin changer. If a changer cannot be repaired by following the guide, return the changer to the nearest Coinco service center for repair. If it is necessary to return the changer to Coinco, please accompany the changer with a brief description of the malfunction to help expedite the repair and return of the changer.

Logic troubleshooting minimizes time spent in removing and replacing modules that are not defective. Some failures are caused by minor problems such as loose or faulty connections. Please check the following before replacing any parts:

Connectors are inserted correctly
Connector pins are not bent or broken
All wires are properly secured
Inventory tubes are filled to their correct levels

NOTE: The following Troubleshooting Guide is based on the fact that the tester or vendor, with which the defective changer is being tested, functions properly when used with a known good changer.

This guide is not intended to cover all failures, but to cover the most common failures.

9300-L / 9302-L TROUBLESHOOTING GUIDE

<u>TROUBLE</u>	<u>POSSIBLE CAUSE</u>	<u>PROCEDURE</u>	<u>REMEDY</u>
No coin acceptance and no payout when inventory switch is actuated. Changer appears to be dead.	No power	Make sure changer is plugged into the vending machine or tester has power	Plug changer into vending machine or tester
		Hinge acceptor down, check red LED next to price switch, if LED is ON	Replace main logic board
		If LED is OFF, check continuity between Jones plug pin 1 and P3 pin 7 Jones plug pin 2 and P3 pin 4 and Jones plug pine 2 and P3 pin 2 (See Fig. 5.0 & 5.1) If continuity does not exist between all 3 pairs	Replace harness
		If continuity does exist between all three pairs check foil fuse on back of main logic board (See Fig. 5.1)	Repair fuse or replace main logic board

SECTION 5: TROUBLESHOOTING

<u>TROUBLE</u>	<u>POSSIBLE CAUSE</u>	<u>PROCEDURE</u>	<u>REMEDY</u>	
		If fuse is good Check transformer as follows: Check between P7 pins 1 and 2 for approximately 18 VAC (See Fig. 5.0 & 5.1) If no voltage or less than 18 VAC + or -10%	Replace transformer	
		If 18 VAC exists	Replace main logic board.	
No coin acceptance Payout solenoids energize when inventory switches are actuated	Coin return lever	Make sure changer is mounted correctly and coin return lever is in proper position	Reposition changer and/or vendor coin return lever	
	Acceptor	Make sure acceptor is plugged in properly	Plug acceptor in properly	
	No blocker (CREM) signal	Hinge acceptor down and check to see that the red LED next to the price option switch is ON		
		If not, check continuity between changer Jones plug pin 6 and P3 pin 4		If no continuity, replace main harness
		If continuity is present	Replace acceptor	
		If still no acceptance	Replace main logic board	
Rejects coins or percentage of good coins	Acceptor		Replace acceptor	
		If still rejects coins	Replace main logic board	

SECTION 5: TROUBLESHOOTING

<u>TROUBLE</u>	<u>POSSIBLE CAUSE</u>	<u>PROCEDURE</u>	<u>REMEDY</u>
Accepts money, but will not vend	Open circuit	Check continuity between Jones plug pin 3 & P3 pin 6 (See Fig. 5.0 & 5.1)	If open, replace main harness
		Check continuity between Jones plug pin 7 & P3 pin 5	If open, replace main harness
	Logic board or acceptor	If continuity is present	Replace logic board
		If still no vend	Replace acceptor
Accepts coins & vends but no payout	Payout solenoid does not energize	Actuate 5¢, 10¢ & 25¢ inventory switches one at a time. If any or all solenoids do not energize check resistance of solenoids in question. Resistance should be .210 ohms + or -10%	Replace solenoid or solenoids in question
		If resistance is correct	Replace tube sensor board
		If still no inventory or payout	Replace main logic board
Incorrect change payout	Main logic board	Check solenoids for correct connection	Connect solenoids correctly
		If solenoid is connection correct	Replace main logic board

**NOTE: If correct change is not available for a \$ bill, the correct change light remains ON.
See Exact Change Condition, Section 3: Operation.**

Exact change light does not flash for an over insertion when correct change is not available	Open circuit	Check continuity between pin 5 of changer 8 pin Jones plug & P3 pin 1, if open	Replace harness
		If harness is not open	Replace main logic board.

SECTION 5: TROUBLESHOOTING

<u>TROUBLE</u>	<u>POSSIBLE CAUSE</u>	<u>PROCEDURE</u>	<u>REMEDY</u>
Vends at wrong price	Logic board	Set vend price to 50¢ and load change tubes. Deposit 25¢. Depress coin return. Deposit 5¢. Depress coin return. Deposit 10¢. Depress coin return. If amount returned doesn't equal amount deposited	Check solenoids for proper connection. If solenoid properly connected
		If the problem still exists	Replace logic board
Coin always goes to cash box	Tube sensor board or acceptor	Check sensor boards for broken or loose components and check cable from sensor board for damage or improper connection	Replace tube sensor board
		If coin still goes to cash box	Replace logic board
Coin always goes to coin tubes	Coin tube gate in open position	Remove acceptor back check solenoid for free operation	Replace acceptor
	Defective tube sensor board	Inspect tube sensor board for loose or broken components, frayed cable, etc.	Replace tube sensor board
		If coin still goes to change tubes	Replace main logic board

SECTION 5: TROUBLESHOOTING

3341-S Interconnect

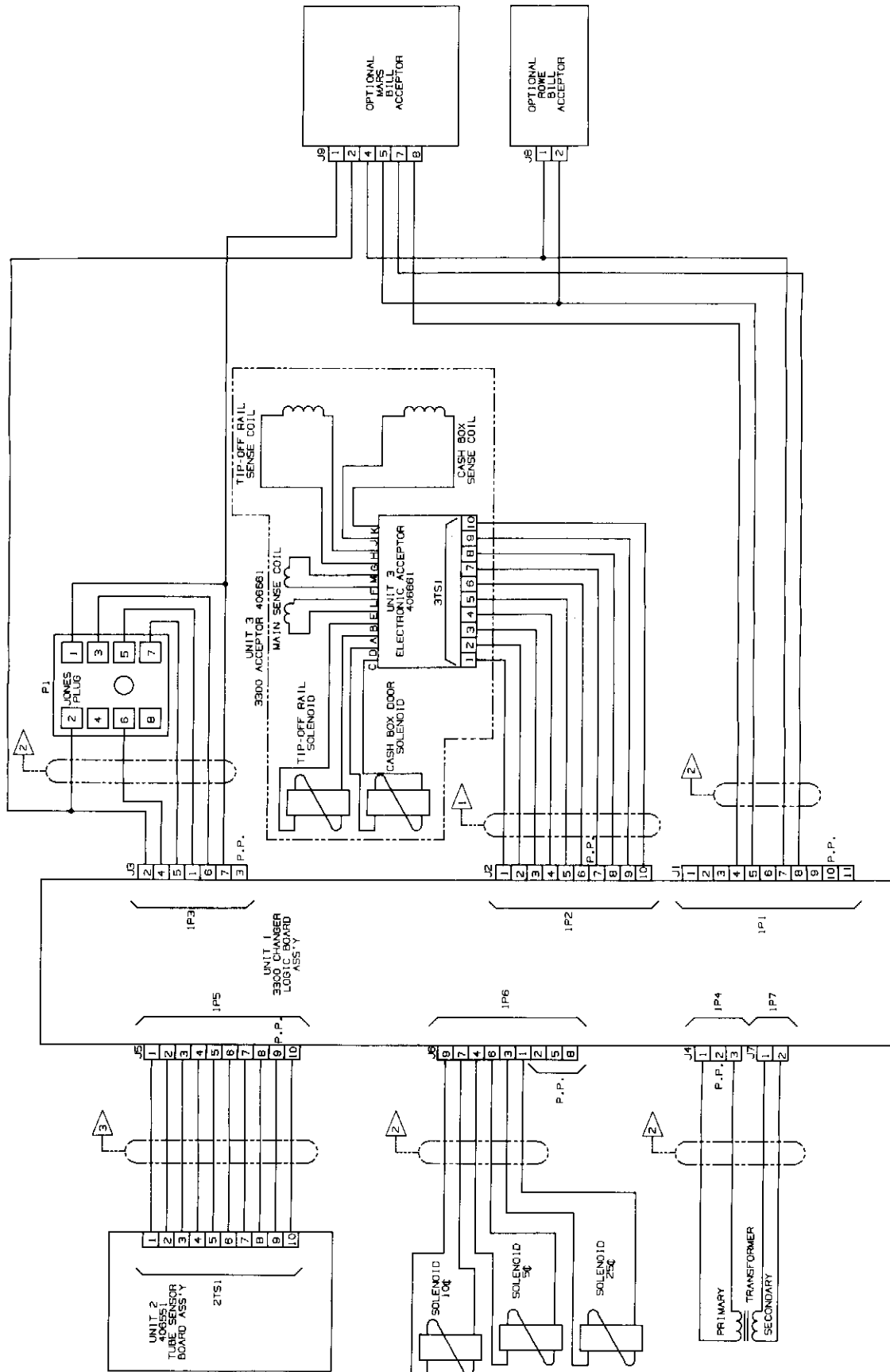

SECTION 5: TROUBLESHOOTING

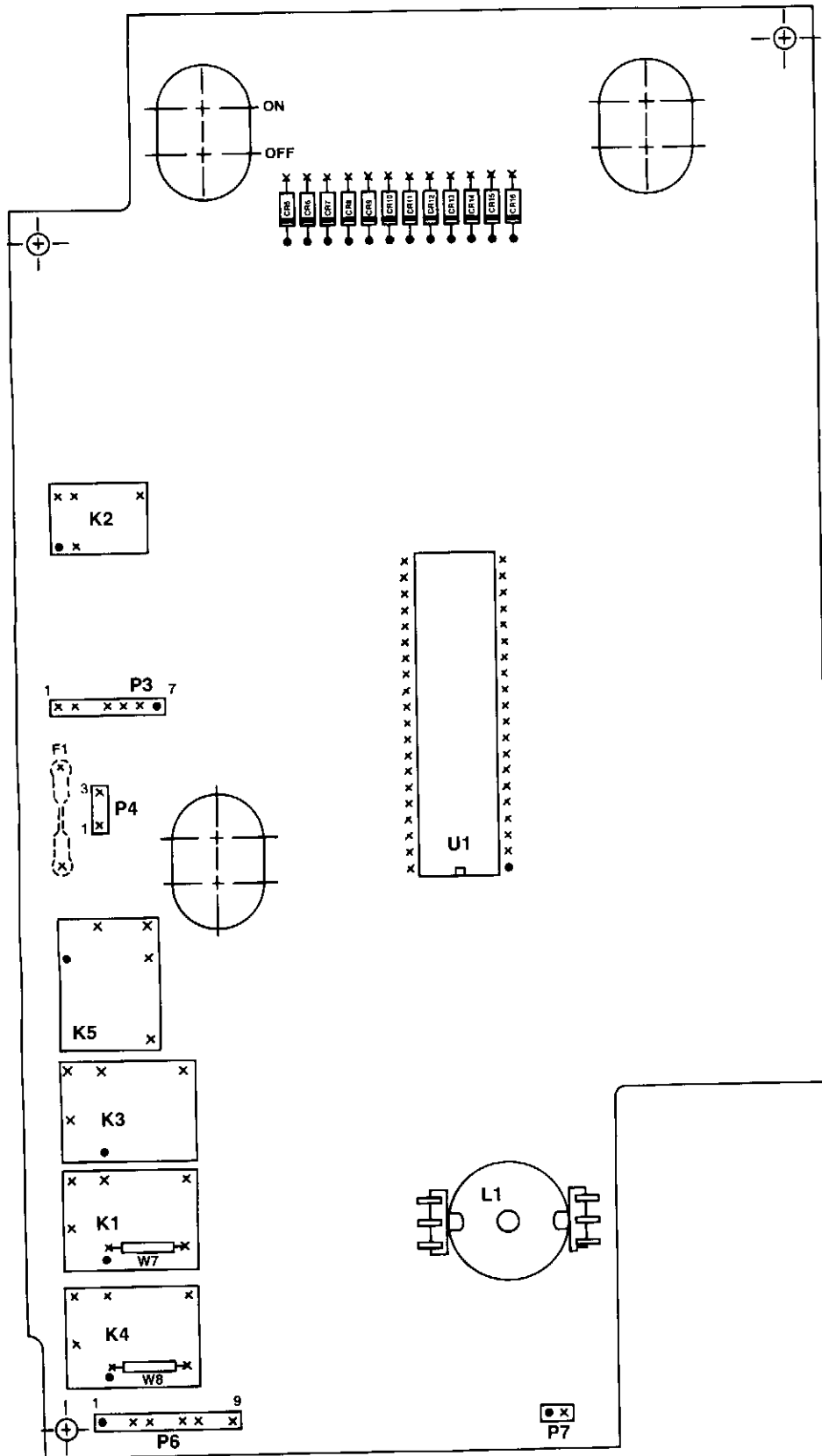
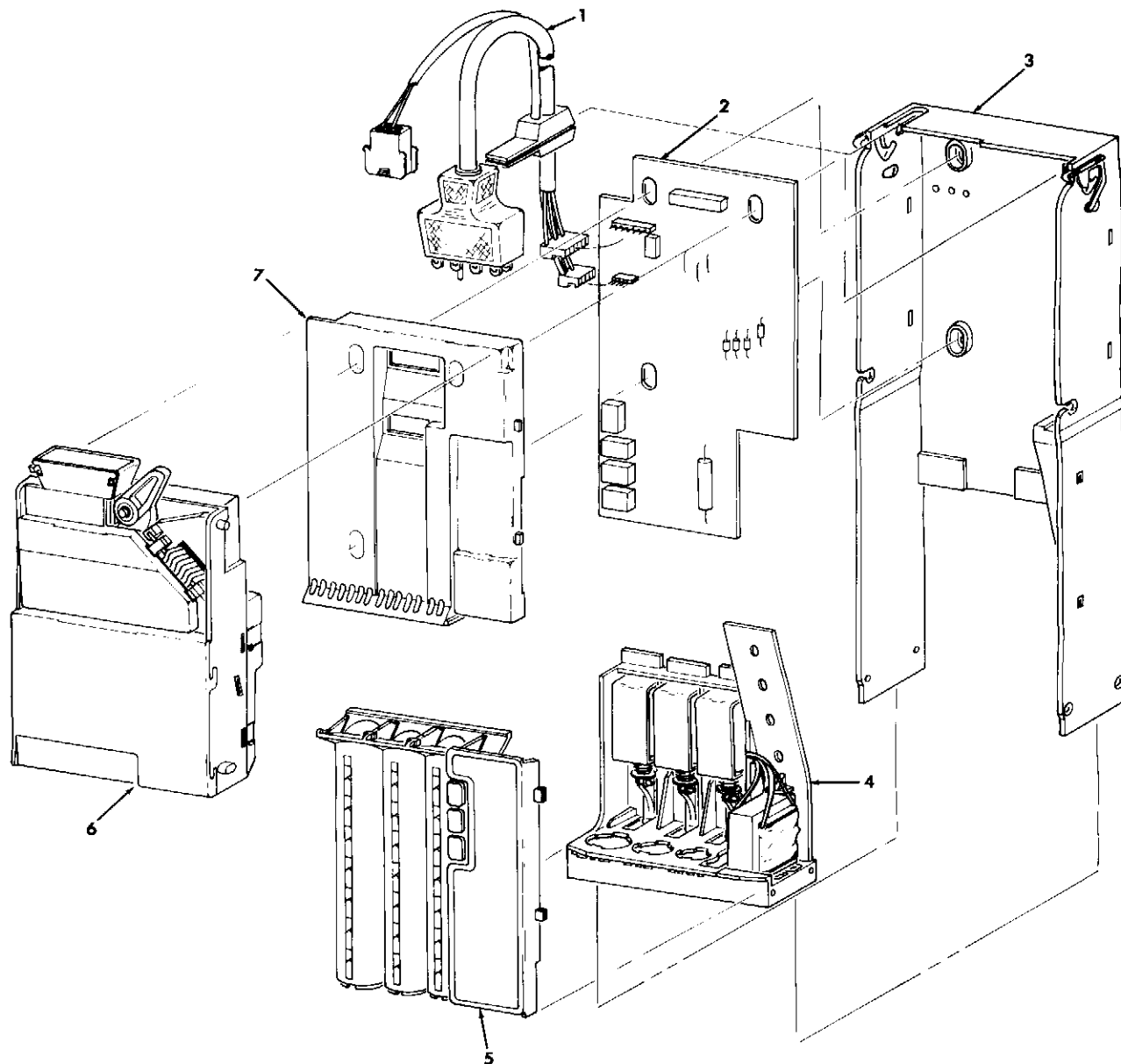

Figure 5.1
Logic Board Partial Layout

SECTION 6: PARTS LIST

Modular View 3000-S Changers



Item No.	Part No.	Description	Quantity	Item No.	Part No.	Description	Quantity
1	406609	Harness, (3100-S 3200-S)	1		406739-7	Payout Assembly 3245-S/SC	1
	406610	Harness, (3240-S,3245-S & 3340-S)	1		406739-2	Payout Assembly 3340-S/SC	1
	406624	Harness, (s3240-SC,3245-SC &3340-SC)	1	5	406728-5	Inventory Tube & Bd. Assy. 3100-S	1
	407384	Harness 3341-S	1		406728-3	Inventory Tube & Bd. Assy. 3200-S & 3240-S/SC	1
2	406660-4	Logic Board, 3100-S	1		406728-4	Inventory Tube & Bd. Assy. 3245-S/SC	1
	406660-3	Logic Board, 3200-S	1		406728-2	Inventory Tube & Bd. Assy. 3340-S/SC	1
	406660-5	Logic Board, 3240-S/SC	1		4066811	Acceptor	1
	406660-2	Logic Board, 3245-S/SC	1	7	909585	Logic Board Cover	1
	406660	Logic Board, 3340-S/SC	1				
	406660-7	Logic Board, 3341-S	1				
3	909100	Changer Housing	1				
4	406739-5	Payout Assembly, 3100-S	1				
	406739-6	Payout Assembly, 3200-S 3240-S/SC	1				

SECTION 6: PARTS LIST

3000-S Series Changer Housing

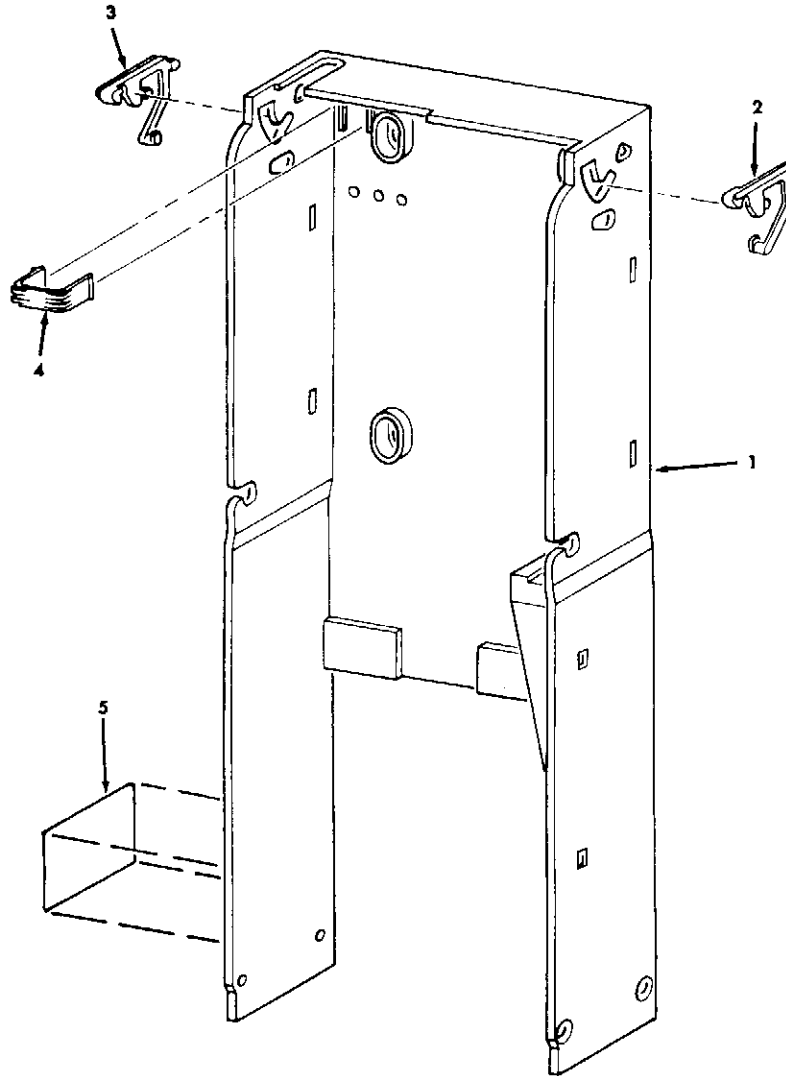

Item No.	Part No.	Description	Quantity
1	909100	Housing (only)	1
2	902011-1	Acceptor Latch, Right	1
3	902010-1	Acceptor Latch, Left	1
4	904195	Harness Clamp	1
5	909729	Label, Identification	1

SECTION 6: PARTS LIST

3000-S Series Payout Assemblies

3100-S	406739-5
3200-S,3240-S/SC	406739-6
3245-S/SC	406739-7
3340-S/SC	406739-2

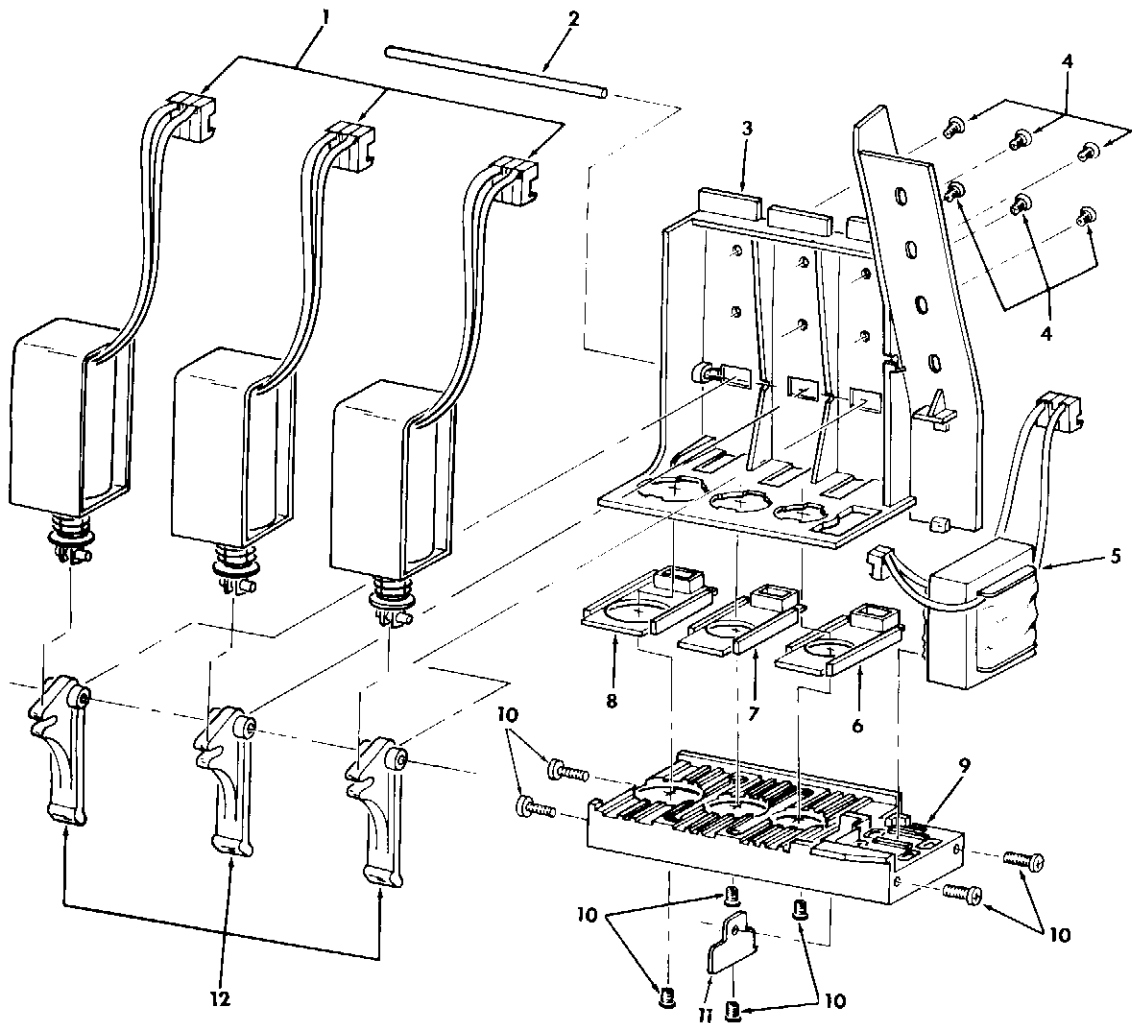

Item No.	Part No.	Description	Quantity	Item No.	Part No.	Description	Quantity
1	406607-1	Solenoid Assy., 110VDC 3100-S	1	7	909104	5¢ Payout Slide (3100-S,3200-S	
		Solenoid Assy., 110VDC 3200-S	2			3240-S/SC,3245-S/SC	
		Solenoid Assy., 110VDC 3240-S/SC	2			&3340-S/SC)	1
		Solenoid Assy., 110VDC 3245-S/SC	2	8	909103	25¢ Payout Slide (3340-S/SC,	
		Solenoid Assy., 110VDC 3340-S/SC	3			3245-S/SC)	1
2	909113	Pivot Shaft	1	9	909102	Lower Payout Base	1
3	909141	Upper Payout Base	6	10	345P4R7	Screw, 4x7/16 PH PHL Plas Blk	8
4	909630	Screw, 6-32x3/16 FH undcut blk	1	11	909135	Coin Return Liner	1
5	406606-4	Transformer Assy., 110VAC, Fused	1	12	909106	Solenoid Lever 3100-S	1
6	909105	10¢ Payout Slide (3200-S,3240-S/SC,	1			Solenoid Lever 3200-S, 3240-S/SC	
		3340-S/SC)				3245-S/SC	2
						Solenoid Lever 3340-S/SC	3

SECTION 6: PARTS LIST

Logic Board Cover Assembly

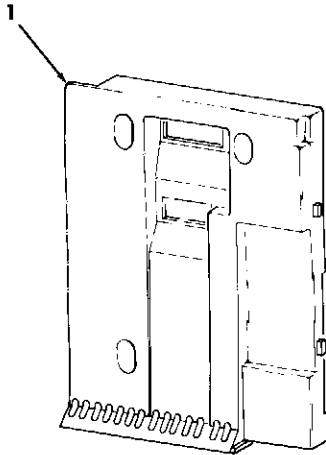

Inventory Tube Assemblies

3100-S	406728-5
3200-S,3240-SC	406728-3
3245-S/SC	406728-4
3340-S/SC	406728-2

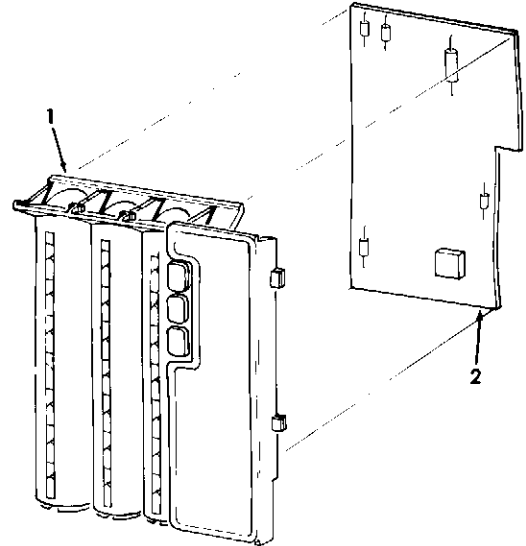

Item No.	Part No.	Description	Quantity
1	909585-2	Logic board cover	1

Item No.	Part No.	Description	Quantity
1	406727-2	Inventory tube assy. 3100-S	1
		Inventory tube assy. 3200S, 3240-S/SC	1
		Inventory tube assy. 3245-S/SC	1
		Inventory tube assy. 3340-S/SC	1
2	406551-1	Board Assy. tube sensors 3100-S	1
		Board Assy. tube sensors 3200-S & 3240-S/SC	1
		Bd. Assy tube sensors 3245-S/SC	1
		Bd. Assy. Tube Sensors 3340-S/SC	1

SECTION 6: PARTS LIST

Acceptor Front View Assembly #406681

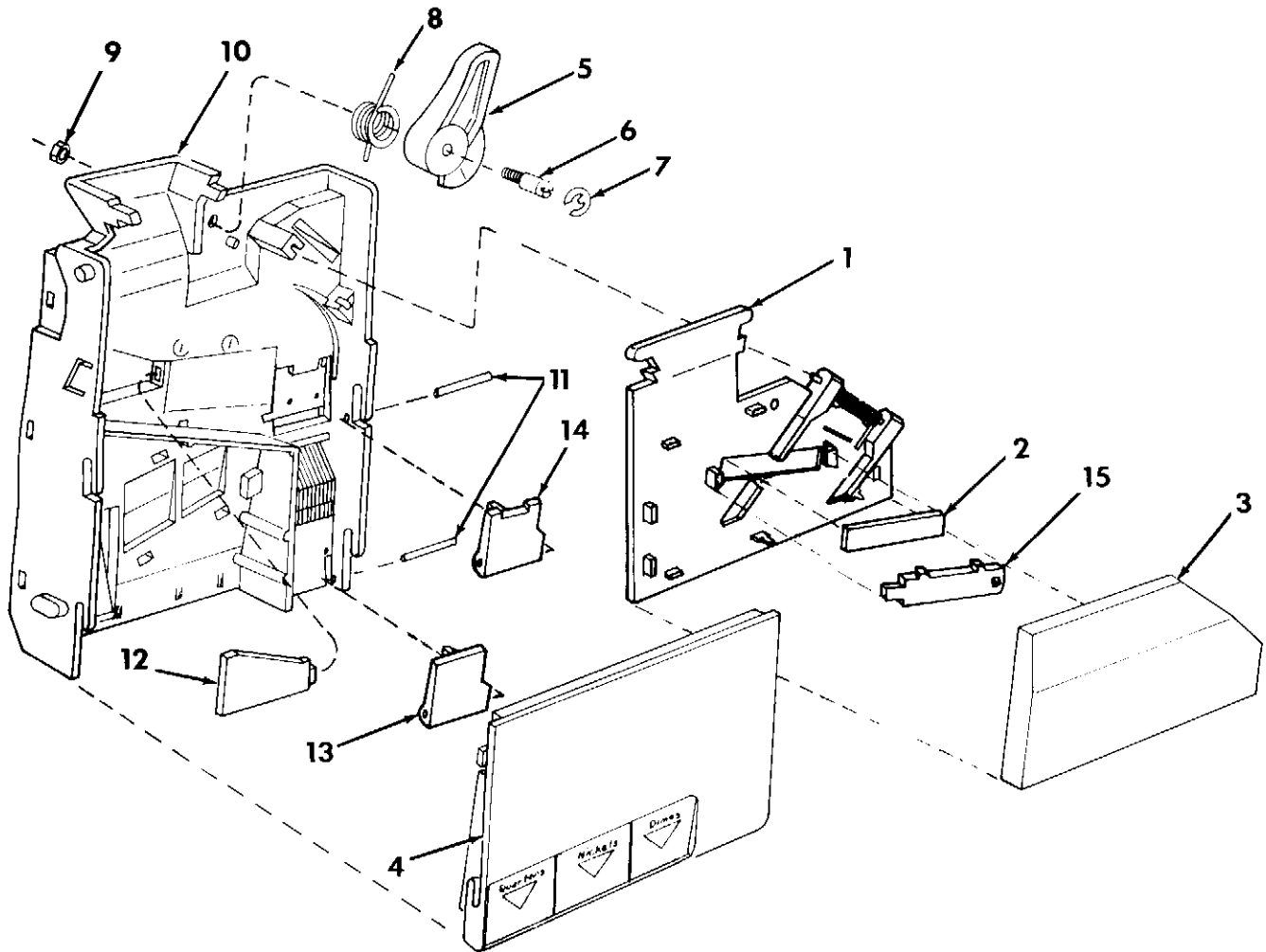

Item No.	Part No.	Description	Quantity
1	406183-3	Gate	1
2	909325	Ferrite, I-Core	1
3	905596-1	Cover, Gate	1
4	909095	Front Cover	1
5	906606-1	Operating Lever	1
6	906624	Screw, Gate Lever Pivot	1
7	751S21X	Retaining Ring	1
8	906618	Spring, Operating Lever	1
9	400C8	Nut, 8-32 Lock	1
10	406676	Mainplate & Coil Assy.	1
11	906622	Pin, Diverter Pivot	2
12	906616	Coin Rail	1
13	909092	Diverter Door	1
14	906600-1	Diverter Door	1
15	909323	Retainer, I-Core	1

SECTION 6: PARTS LIST

Acceptor Back View Assembly #406681

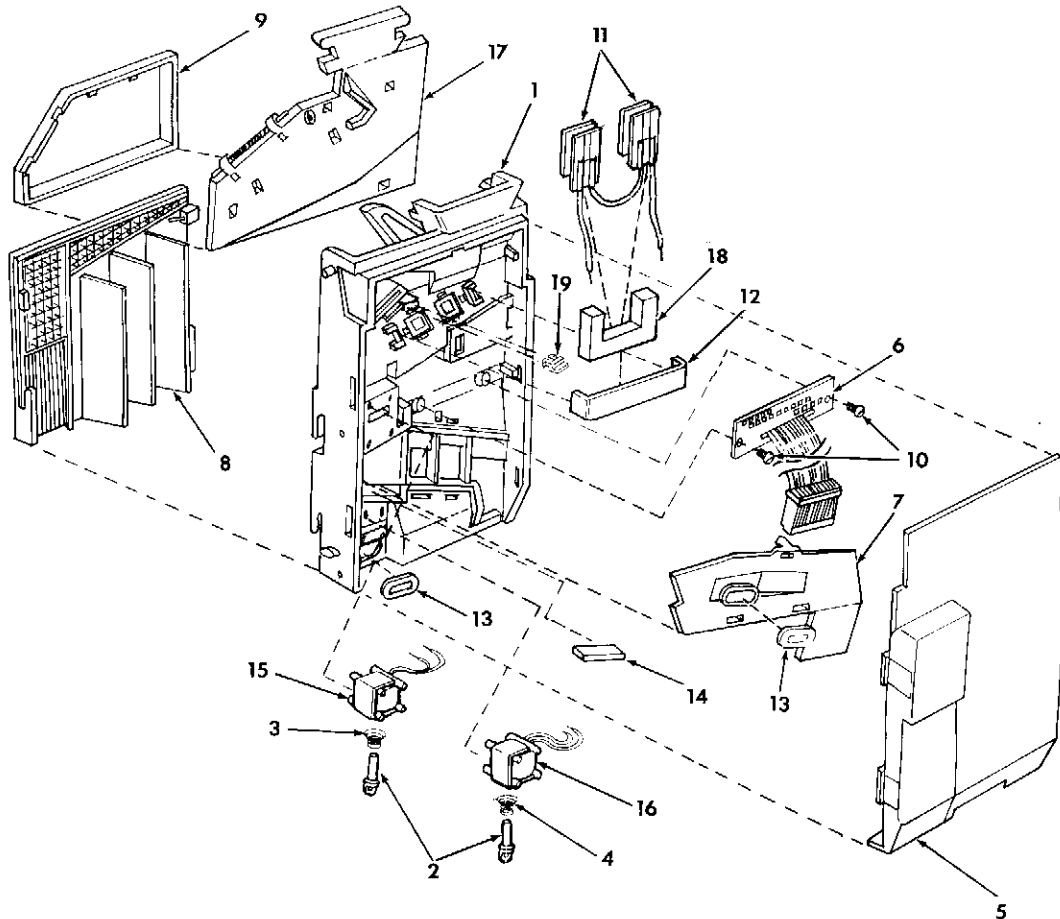

Item No.	Part No.	Description	Quantity	Item No.	Part No.	Description	Quantity
1	406676	Mainplate & Coil Assy.	1	10	345-4-4	Screw, #4x1/4 PH Plas	2
2	406167	Plunger & Yoke Assy.	2	11	406675	Bobbin Assembly	2
3	906619-2	Spring, copper-plated	1	12	909324	Retainer, U-Core	1
4	906619-1	Spring, nickel-plated	1	13	406613-1	Coil Assembly, Sensing	2
5	909096	Back Cover	1	14	909853	Coin Rail	1
6	406661	Board assy.,	1	15	406857	Coil Assy. Solenoid, Upper	1
7	406612-1	Chute & coil assembly	1	16	406857-2	Coil Assy. Solenoid, Lower	1
8	909095	Front Cover	1	17	406183-3	Gate	1
9	906596-1	Cover gate	1	18	909326	Ferrite, U-Core	1
				19	908845-1	Plug, Spring Retensiong	1