



AUTOMATIC PRODUCTS/RMI

203

**HOT DRINK MERCHANDISER
SERVICE MANUAL**



TABLE OF CONTENTS

AP 203

AP 203 INTRODUCTION AND INSTALLATION	
INTRODUCTION	1.01
HOW TO USE THIS MANUAL	1.01
FEATURES OF AP 203 HOT DRINK MERCHANDISER	1.02
SPECIFICATIONS	1.02
INSTALLATION AND SET-UP INSTRUCTIONS	1.03
TRAINING TEMPLATE	1.06
203 ELECTRONICS CONTROL SYSTEM - INTRODUCTION	
USE OF KEYBOARD	2.02
MODE 1 - DISPLAY REPORT	2.03
MODE 2 - TEST VEND	2.03
MODE 3 - FLUSH CYCLE	2.04
MODE 4 - SET CASH PRICES	2.04
MODE 5 - SET DEBIT PRICES	2.04
MODE 6 - DIAGNOSTICS	2.05
MODE 7 - CHANNEL TIMED TEST	2.05
MODE 8 - CHANNEL CONTINUOUS TEST	2.05
MODE 9 - UPLOAD SETTINGS TO MACHINE	2.05
MODE 10 - DOWNLOAD SETTINGS FROM MACHINE	2.05
MACHINE TO MACHINE UPLOAD/DOWNLOAD	2.06
MODE 11 - MACHINE CONFIGURATION	2.06
MODE 12 - SET TIME CHANNELS	2.07
MODE 13 - SET OPTIONS	2.08
MODE 14 - SET DISCOUNT BITS	2.09
MODE 16 - LOAD STANDARD SETTINGS	2.09
MODE 17 - PROGRAMMING USER MESSAGE	2.10
APPENDIX I: 203 MACHINE - CHANNEL NUMBERS & STANDARD TIME	2.11
APPENDIX II: 203 SWITCH NUMBERS	2.12
APPENDIX III: "OUT OF ORDER" CODES	2.13
APPENDIX IV: HEATER CIRCUIT WIRING	2.14
SERVICE INDEX	3.01
PARTS INDEX - SEE SEPARATE MANUAL	4.01

(FOR USE WITH SOFTWARE DATECODE 022890 OR LATER)



FEATURES OF AP 203 HOT DRINK MERCHANDISER

SELECTION SYSTEM

- o Four prime selections each with three programmable strengths plus chocolate and soup.
- o Easy to use color coded selection buttons for variable strength products.
- o Over 330 selections possible.
- o Coffee strength variable by changing throw and/or brewing time.
- o Artificial sweetener available.
- o Variable strength additives.
- o Easy to change selection labels.
- o Selection lamps and audible tone feedback for touch sensitive buttons.
- o Multi-vend possible.
- o Coins for the next vend can be inserted before the end of the current vend.

PRICING

- o All selections individually priced.
- o Two price levels for variable strength selections.
- o Separate discount pricing structure available.
- o Separate debit card pricing available.
- o Programmable winner mode available as standard.
- o Free vend feature.
- o Forced vend and bill escrow features.
- o Full accountability including ten separate price line counters and discount cash meter and counter

SCROLLING DISPLAY

- o User friendly scrolling display to help with the selection process and provide customer feedback.
- o Programmable for stand-by "operator" messages, up to 85 characters long.

OPTIONS

- o 12 ounce brewed coffee
- o Fresh brewed tea
- o Whipped GFIC or gourmet coffee
- o USE YOUR OWN CUP option with or without discount feature
- o 24V (standard) or 110V capability for coin mech or validator

SPECIFICATIONS

DIMENSIONS:

Height: 72" Depth: 31" Width: 38"

ELECTRICAL AND WATER REQUIREMENTS:

Electrical: 120 Volts; 60 Hz; 16 Amps
Water: Potable cold water, 20 psi minimum

SHIPPING WEIGHT

Freeze-dried	460 lbs.
Loose ground	500 lbs.
Grinder	560 lbs.

MODELS AND CAPACITIES

Ingredient:	Capacities lbs.					
	DG	G	GLG	DH	LG	FD
Regular Coffee Beans	11	16	11.5	-	-	-
Decaf. Coffee Beans	5	-	-	-	-	-
Regular Ground Coffee	-	-	-	11	12	-
Decaf. Ground Coffee	-	-	3.5	4.5	-	-
Freeze Dried Coffee	-	-	-	-	-	3
Soluble Coffee/Decaf.	1.5	1.5	1.5	1.5	1.5	1.5
Tea Leaf-Fresh brewed	2.5	2.5	2.5	2.5	2.5	2.5
or Instant	1.5	1.5	1.5	1.5	1.5	1.5
Sugar	8	8	8	8	8	8
Sugar Substitute	10oz	10oz	10oz	10oz	10oz	10oz
Whitener	4	4	4	4	4	4
Chocolate	12	12	12	12	12	12
Soup	4	4	4	4	4	4

CUPS:

7oz	780
8 1/4oz	720
12oz	615

AP 203 INSTALLATION AND SET-UP INSTRUCTIONS

INSTALLATION

Unpack the vendor:

1. Remove shipping carton and plastic bag from vendor. Inspect exterior of cabinet for damage.
2. Remove clip from lock handle and open front door. If machine is equipped with a lock, the keys will be in the cup well. Inspect cabinet interior for evidence of damage.
3. Remove packing tape from coffee hopper swing out bracket, cup dispenser door, commodity trough and steam deflector, overflow and grounds waste floats.
4. Remove all cartons from floor of machine. These cartons will contain the kickplate, grinder swing out bracket, coffee or bean hoppers.
3. If the machine is a 203G or DG or GLG, the swing out bracket assembly and hopper will be packed separately and placed on the floor of the machine. After unpacking, they can be installed on the hinge bracket and the electrical harnesses connected. Be sure to secure the sliding gate (located on the sloped surface of the bean hopper) in the fully open position to allow beans into the grinder(s). Install coffee delivery chute to bottom of swing out bracket and position for best possible delivery of grounds to brewer.
4. Install water filter cartridge (if so equipped). Close water tank drain valve.
5. Remove brewer sheet metal cover. Locate 1/4-20 shipping bolt behind brewer latch, remove using 3/8" socket or wrench. Remove cup dispenser shipping screw and nut.

LOCATION SITE REQUIREMENTS

This vendor requires an external source of water and electricity for operation. The minimum requirements for these utilities are as follows:

WATER

The installation site must have a cold drinking water supply line that can be permanently coupled to the vendor. The water line should be one-half inch minimum diameter and be equipped with a manual shutoff within six feet of the machine. Water pressure should maintain 20 psi minimum while the vendor is taking on water. If water pressure exceeds 90 psi, a pressure regulator should be installed in the line.

ELECTRICITY

A grounded electrical outlet rated at 120 volts, 60Hz, single phase and capable of delivering 20 amperes must be available within six feet of the vendor.

SET-UP INSTRUCTIONS

Set up the vendor at the location as follows:

1. Carefully level the vendor front to back and side to side.
2. Swing coffee hopper support bracket out and install hopper. Be sure to engage auger driver with motor drive pin. Connect two harness leads to thumper solenoid.
7. Plug machine into a 120V 20A receptacle. Set all three switches to the on position. Check that the tank starts to fill and that there are no leaks. The cup spiral motor will run for thirty seconds or until the cup present switch is depressed. The machine is equipped with a safety feature - if the inlet water valve is on for more than 90 seconds it will put the machine 'OUT OF ORDER'. To complete the filling of the heater tank you will have to power down-power up the control board to reset the 90 second timer.
- ◆ DO NOT LIFT THE FLOAT ROD OR SWITCH WHILE THE TANK IS FILLING. THIS WILL SIGNAL THE LOGIC BOARD THAT THE TANK IS FULL AND THE HEATERS WILL BE TURNED ON REGARDLESS OF THE LEVEL OF WATER IN THE TANK.
8. Remove the packing block on top of the chocolate canister.
9. Remove packing tie downs holding the rinse hose to the top of the humidity bar.
10. Loosen the two screws holding the brewer grounds splash guard on the front of brewer. The shield is designed to be able to swing a little as the spent grounds fall against it.

11. Install grounds bucket liner (supplied). Install grounds bucket behind front flange of rear splash guard. Be sure that the float is inside the bucket.
 12. Install overflow bucket against guide on lower left corner of machine. Be sure that the float and overflow hose(s) are inside the bucket.
 13. Fill canisters and hoppers with product.
 14. Open cup dispenser door and load with cups. Cup dispenser is set for 7 oz. or 8 1/4 oz. cups. If 9 oz. cups are desired, refer to service section for adjustments.
 15. Install 24V 'dummy' coin mechanism (and bill validator if so equipped). Connect all harnesses.
- ◆ If the machine was ordered with a factory installed 110v conversion, this will be indicated by the presence of a small box located directly below the coin return well on the interior of the door. **Be sure the correct coin mech and validator are installed.**
16. Access selector assembly by swinging out cup dispenser and lowering logic control and LED board panel. Install price labels on selection labels and insert into appropriate positions. See Figure 1.01, page 1.05.
 17. Install the training template over the selection panel using the directions on the template.

REFER TO AP 203 OPERATING SECTION FOR FURTHER INFORMATION ON STEPS 18 THROUGH 20:

18. Access **MODE 11** using the security key on the inside of the door and check that the configuration and options are set correctly for the machine. Proceed to **MODE 13** and set payment options. If discount mode is being used, selections being discounted must be assigned in **MODE 14**.
- ◆ The correct function of the key switch is: on then off - the key should always be in the position where key can be removed.
19. Set selection prices by accessing **MODE 4** and assigning prices to selections. Mild and regular strength beverages are automatically assigned the same price while each strong beverage may be assigned a different price.
- ◆ **SETTING PRICES TO 0.00 WILL SET A SELECTION TO FREE VEND.**

- ◆ **SETTING A PRICE TO 99.99 WILL DISABLE A SELECTION AND CAUSE THE MESSAGE 'MAKE ANOTHER SELECTION' TO APPEAR WHEN THE SELECTION IS PRESSED. THIS IS USEFUL FOR BLOCKING UNUSED SELECTIONS OR DISABLING A SELECTION WHEN IT IS OUT OF ORDER.**

20. Adjust commodities for the correct throw by accessing **MODE 12** (see below). After confirming that the times for liquids are correct, cup levels should be adjusted using flow restrictor on each commodity valve.
21. After completing the product adjustments, install the commodity chutes. Install the humidity bar (heater) on the canister rack so that the tabs on the humidity bar fit into their respective slots between the canisters. Connect the humidity bar harness to the machine harness (located to the left of the chocolate canister).
22. Install chocolate whipper mixing bowl cover.
23. Test all selections and additives with coins (and bills).

ADJUSTING COMMODITY AND LIQUID AMOUNTS

Entering **MODE 12** provides access to the channels which control the dispense times of all ingredients. The dispense time of each commodity and its sequence in the vend cycle is controlled by the microprocessor. Precise time adjustments determine the exact amount of ingredients dispensed. This exact time sequence ability enables accuracy to 1/100 of a second.

Each channel (numbered 02 through 71) has up to three separate settings within each channel. The settings are accessed by pressing the start/enter selection. The three settings are **START**, **DURATION** and **MODIFIER**. Each of these settings can be adjusted by increasing or decreasing the digits shown on the scrolling display by pressing the increment digit (coffee strong) or the next digit (coffee regular) buttons. See Appendix I on page 2.11

The **START** time of each channel indicates the time each function or commodity begins within each vend cycle. All times are permanently stored to guarantee the correct sequence of operation.

The **DURATION** determines the length of time within the vend cycle that each channel will operate. The amount of ingredient for a medium strength selection is controlled by adjusting the duration. After confirming that the duration for liquids are set correctly, cup levels should be set by adjusting the flow restrictor on the commodity valves.

Some channels have a third setting - a **MODIFIER**. This modifier appears in the scrolling display as a number below 1.00. The **MODIFIER** value is the percentage of increase or

decrease in ingredient throw for a strong or mild selection. For example, a **MODIFIER** of .25 on channel 15 (brewed coffee-sugar) means that for an extra sugar selection the sugar motor will run 25% longer and for a lesser sugar selection, the motor will run for a period of time that is 25% shorter.

It is important to press **START/ENTER** after changing any one of these settings and returning to **MODE 12** to ensure that all new values are entered.

Each channel can be tested by pressing the **MODE 12 CHANNEL TEST** switch (regular lightener).

- ◆ ~~Once the durations for the additives (lightener, sugar, sugar substitute) have been set correctly for the brewed coffee channels, these duration times can be duplicated and entered into the channels for freeze-dried products and tea selections to simplify the set up procedure.~~
- ◆ Standard times, settings and prices can be reloaded using **MODE 16**. See **MODE 16** for more information.

TIMING CHART #1

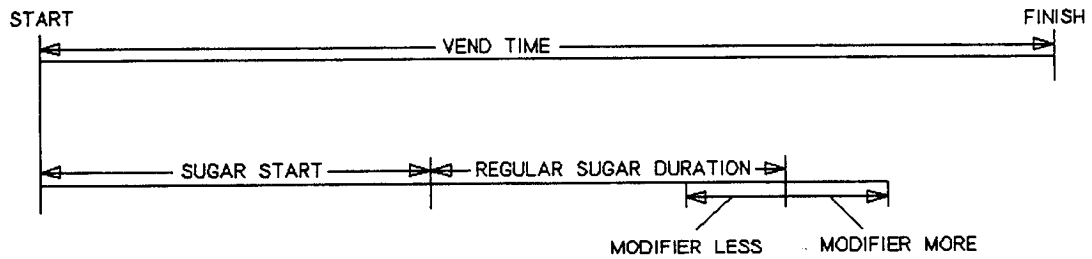

**FIGURE 1.01
SELECTION LABEL ASSIGNMENTS**

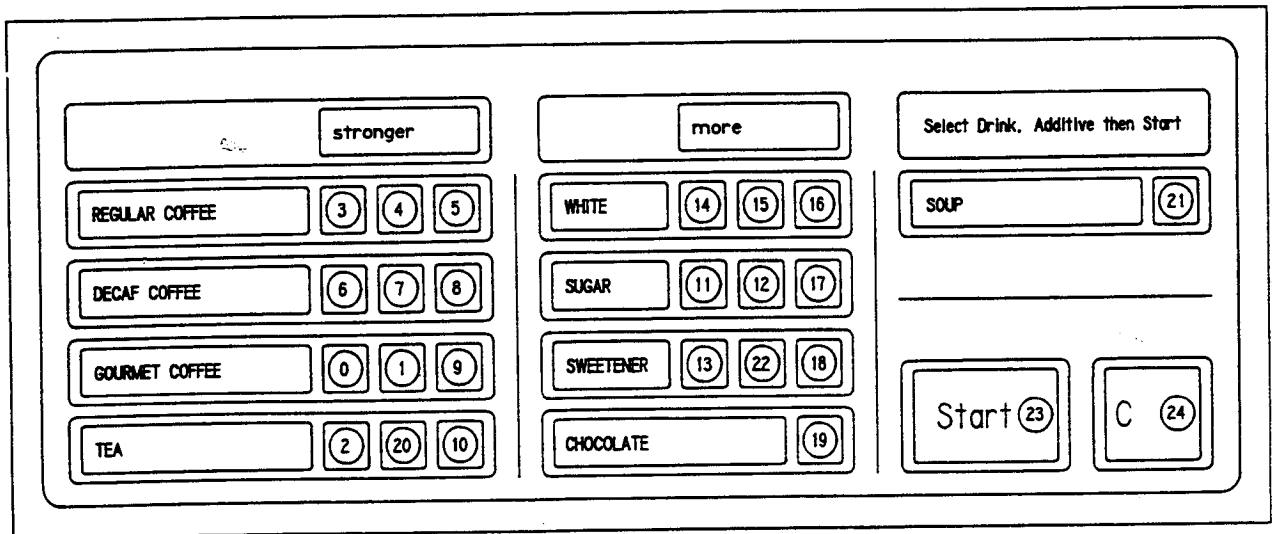



**AP 203 TRAINING TEMPLATE
INSTALLATION INSTRUCTIONS**

1. WITH MACHINE IN NORMAL OPERATING CONDITION, PRESS ANY COFFEE SELECTION AND ALIGN THE BLINKING LEDS WITH THE SMALL SQUARES ON THE TEMPLATE.
2. PRESS THE CANCEL(RED) BUTTON, THEN PRESS THE LED ALIGNMENT TEST BUTTON AND CONFIRM THAT THE SQUARES ARE ALIGNED WITH THE BLINKING LEDS.
3. SECURE THE TEMPLATE TO THE DOOR WITH TAPE AND PROCEED WITH THE SET UP OF THE MACHINE FOLLOWING THE INSTRUCTIONS PROVIDED IN THE MANUAL.

OUT OF ORDER CODES

M01 Out of cups
M02 No Water
M04 Heater Failure
M10 EPROM Mismatch
M20 No AC (Bucket float up)

Codes are additive: M07 equals M01 + M02 + M04

DESCRIPTION OF MC

MODE 0: OPERATE MOC

DOOR KEY REQUIRED:

MODE 1: DISPLAY ACCC
MODE 2: TEST VEND.
MODE 3: MANUAL FLUS
MODE 4: SET CASH PRI
MODE 5: SET DEBIT PRI
MODE 6: DIAGNOSTICS.
MODE 7: CHANNEL TIMI
MODE 8: CHANNEL CON
MODE 9: UPLOAD TIME
MODE 10: DOWNLOAD TI

SECURITY KEY REQUIRED

MODE 11: MACHINE CON

	FLASHING
OPT 1 Y/N	Brewed regular
OPT 2 Y/N	Brewed decaf c
OPT 3 Y/N	Espresso
OPT 4 Y/N	Fresh brewed t

MODE 12: SET CHANNEL
MODE 13: SET PAYMENT
MODE 14: SET DISCOUN
MODE 16: LOAD STAND
MODE 17: PROGRAM SCI

SCROLLING DISPLAY A → ○

**MOVE
FLASHING
DIGIT**

○ SCROLLING DISPLAY C ↑

**INCREASE
FLASHING
DIGIT**

5¢

10¢

25¢

COIN DISPENSE

**LED
ALIGNMENT
TEST**

SCROLLING DISPLAY B ← ○





SECTION OF MODES

OPERATE MODE

- KEY REQUIRED:**
 DISPLAY ACCOUNTABILITY INFORMATION.
 TEST VEND.
 MANUAL FLUSH CYCLE.
 SET CASH PRICES.
 SET DEBIT PRICES.
 DIAGNOSTICS.
 CHANNEL TIMED TEST.
 CHANNEL CONTINUOUS TEST.
 UPLOAD TIMES AND PRICES.
 DOWNLOAD TIMES AND PRICES.

- KEY REQUIRED:**
 MACHINE CONFIGURATION - H/B/C.

	FLASHING Y	FLASHING N
/N*	Brewed regular coffee	No brewer-FD coffee
/N*	Brewed decaf coffee	No brewer-FD decaf.
/N*	Espresso	Soup
/N*	Fresh brewed tea	FD tea or no tea

- SET CHANNEL TIMES.
 SET PAYMENT OPTIONS.
 SET DISCOUNT BITS.
 LOAD STANDARD TIMES AND PRICES.
 PROGRAM SCROLLING MESSAGE.

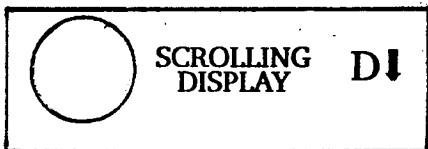
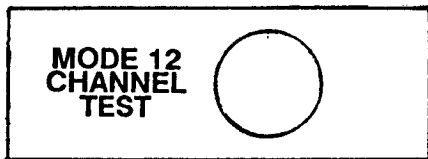

LED ALIGNMENT

CHANNEL	FUNCTION	G	DG	GLG	LG	DH	FD
02	VEND TIME	S	S	S	S	S	S
03	CUP DROP	S	S	S	S	S	S
04	LARGE GRINDER - REG.	A	A	A			
06	LG - REG COFFEE				A	A	
07	LG/SMALL GRINDER - DECAF		A	A		A	
08	BREW MOTOR - COFFEE	S	S	S	S	S	
09	WATER - COFFEE BREW	A	A	A	A	A	
11	X-STRONG DELAY	S	S	S	S	S	
12	PRESSURE RELIEF DELAY	S	S	S	S	S	
13	MAKE UP WATER - COFFEE BREW	A	A	A	A	A	
14	WHITENER AUGER-COFFEE BREW	A	A	A	A	A	
15	SUGAR AUGER - COFFEE BREW	A	A	A	A	A	
16	SUGAR SUB AUGER-COFFEE BREW	A	A	A	A	A	
18	WATER - COFFEE FD + TEA FD	C	C	C	C	C	A
20	COFFEE FD AUGER						A
21	DECAF FD AUGER						A
22	COFFEE FD GOURMET AUGER	A	A	A	A	A	A
23	WHITENER AUGER - COFFEE FD	A	A	A	A	A	A
24	SUGAR AUGER - COFFEE FD	A	A	A	A	A	A
25	SUGAR SUB AUGER - COFFEE FD	A	A	A	A	A	A
26	WATER - TEA BREW	B	B	B	B	B	B
27	TEA FD AUGER	A	A	A	A	A	A
28	TEA BREW AUGER	B	B	B	B	B	B
29	BREWER MOTOR - TEA	B	B	B	B	B	B
30	WHITENER AUGER - TEA FD	A	A	A	A	A	A
31	SUGAR AUGER - TEA FD	A	A	A	A	A	A
32	SUGAR SUB AUGER - TEA FD	A	A	A	A	A	A
33	WATER/WHIPPER - CHOCOLATE	S	S	S	S	S	S
34	CHOCOLATE AUGER	A	A	A	A	A	A
35	WATER/WHIPPER - SOUP	S	S	S	S	S	S
36	SOUP AUGER	A	A	A	A	A	A
56	WHIPPER - COFFEE BREW	C	C	C	C	C	C
57	WHIPPER - COFFEE FD	C	C	C	C	C	C
66	WHITE AUGER - TEA BREW	B	B	B	B	B	B
67	SUGAR AUGER - TEA BREW	B	B	B	B	B	B
68	SUGAR SUB AUGER - TEA BREW	B	B	B	B	B	B
71	WHIPPER - GOURMET COFFEE	C	C	C	C	C	C

NOTE: Due to a maximum of seven spaces on the canister rack, including soup and chocolate, some of these channels may not be available on each machine.

KEY

- S Standard time - should not be adjusted
 A Measure and Adjust
 B Use for Brewed Tea
 C Check manual for specific uses before adjusting
 BLANK .. Not used in this model

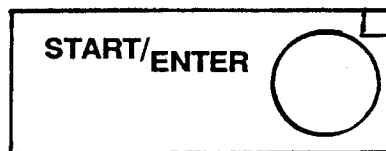



203 ELECTRONICS CONTROL SYSTEM - INTRODUCTION

There are 18 modes in which the control system can operate. The various modes are used to access the accountability data, set up the machine and perform service diagnostics.

Mode 0 - The normal operating mode of the machine during which a user may enter coins or a debit card and select a drink.

Modes 1 - 10 - Service modes accessible by operation of the "mode" switch inside the machine. This switch is accessible once the door is opened i.e. only the door key is required.

Modes 11 - 17 - Additional service modes accessible only if a key for the "security" switch is used.

DESCRIPTION OF MODES

Mode 0: Operate mode. Normal operating mode.

Door key required:

- Mode 1:** Display report. Displays accountability information.
- Mode 2:** Test vend. Allows one test vend without credit.
- Mode 3:** Manual flush cycle. Used to flush the mixing channels and bowls with water.
- Mode 4:** Set cash prices. Used to set/check the cash prices of all selections.
- Mode 5:** Set debit prices. Used to set/check the debit prices of all selections.
- Mode 6:** Diagnostics. Checks all segments of the scrolling display, all indicator lamps and lists closed switches.
- Mode 7:** Channel timed test. Selected channel is turned on for the normal vend duration time.
- Mode 8:** Channel continuous test. Selected channel is manually turned on until is manually turned off again.
- Mode 9:** Upload RS232C. Allows uploading of machine parameters from a programming device to the machine control board.

Mode 10: Download RS232C. Allows the downloading of the machine parameters from the control board to a programming device.

SECURITY KEY REQUIRED:

- Mode 11:** Machine configuration. Allows definition of machine type and options.
- Mode 12:** Set channel times. Used to set start and duration times and strength modifiers.
- Mode 13:** Set Options. Used to set payment options.
- Mode 14:** Set discount bits. Used to indicate selections to be discounted.
- Mode 15:** Not used on the 203 hot drink machine.
- Mode 16:** Load standard times and prices. Used to load factory standard time settings.
- Mode 17:** Smart display user message. Used to program the scrolling message using the machine keyboard.

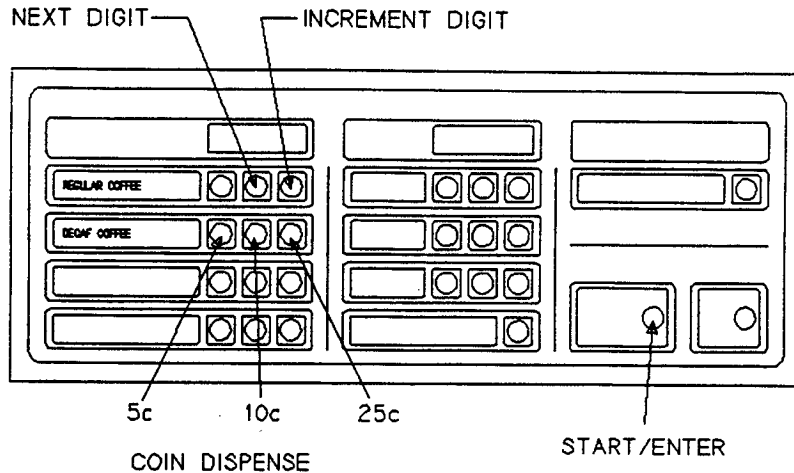

USE OF KEYBOARD

When in any of the service modes the selection panel switches perform different functions. A diagram showing the function of the switches is given in the figure above.

COIN DISPENSE

At any time, in any service mode, the three switches for decaffeinated coffee can be used to dispense coins from the changer:

Mild strength -	Nickels
Regular strength -	Dimes
Strong -	Quarters

INCREMENT & NEXT DIGIT

There are two buttons to carry out the changing of modes and values appearing on the scrolling display. Modes can also be incremented using the **mode** switch, inside the door. The **increment digit** button (coffee strong) is used to increase the value of the flashing digit e.g. from *13* to *14*. The value of the digit will return to *0* after *9*.

The **next digit** button (coffee regular) is used to move to the next digit (indicated by the flashing character), like a watch set up, e.g. from *24* to *24* and then to *_24*. Repeated pressing will return the flashing digit to the right hand position.

ENTER

The **START** selection switch is used as the **ENTER** button.

SPECIAL BUTTONS

Additional functions are available with other switches and are explained in the appropriate sections of this manual.

TO EXIT SERVICE MODE

The service mode can be exited at any time by one of the following:

- Depress **mode** switch until scrolling message returns.
- Depress coin return button.
- Deposit coins or a bill into the machine.
- Remove and reapply power to machine or control board
- If the machine is left long enough without depressing any switches it will automatically return to the normal operate mode.

TEMPLATE

A template is provided to simplify the use of the keyboard. When correctly aligned on the selection switch panel it provides the alternate meanings of the switches. See page 1.06

TRAINING VIDEOTAPE

An introductory video tape (VHS) explaining all the modes and the uses of various switches on the selector panel is available. The AP 203 video tape can be ordered from your distributor or RMI under part number 750142.

MODE 1 - DISPLAY REPORT

1. Open machine door.
2. Depress the **mode** switch until the display indicates 'MODE 01'.
3. Depressing the **START** front panel selection switch, the display will indicate 'M0', followed by '- XXXX'. This is the total vend count.
4. Depress the **START** front panel selection switch again and the display will indicate 'M1', followed by '- XXXX.XX'. This is the cash total taken by the machine.
5. Depress the **START** front panel selection switch again and the display will indicate 'M2', followed by '- XXXX.XX'. This is the cash value of all discounts given.
6. Depress the **START** front panel selection switch again and the display will indicate 'M3', followed by '- XXXX.XX'. This is the total value of bills taken.
7. Depress the **START** front panel selection switch again and the display will indicate 'M4', followed by '- XXXX'. This is the total number of discount vends.
8. Depress the **START** front panel selection switch again and the display will indicate 'M5', followed by '- XXXX.XX'. This is the total value of card vends.
9. Depressing the **START** front panel selection switch again will cause the machine to display an additional breakdown of the vend totals by price line:

 'MP01 X.XX' (Price 1) 'MC01 XXXX' (Vends for price 1)

 'MP10 X.XX' (Price 10) 'MC10 XXXX' (Vends for price 10)

 'M\$\$' 'XXXX' (Cash value of all vends whose prices are not one the 10 specified)

 Note: The M\$\$ total does not have a decimal point in the display. The last two digits represent the cents portion of the total.

 ♦ If multiple price lines are being used - set the most commonly used prices in the lowest possible price line counter. These price line counters are set in **MODE 13**.
10. Press coin return button to return to operate mode.

Note: The next mode can be entered by either pressing the **MODE** switch inside the door or by using the **increment digit** and **next digit** switches on the selection panel.

The following chart is a graphic representation of the steps for retrieving the accountability information from MODE 1.

START MEANS PRESS THE START BUTTON ONCE

	SCROLLING DISPLAY WILL SHOW	EXPLANATION
START	M0 000000	VEND COUNT
START	M1 0000.00	CASH METER
START	M2 0000.00	DISCOUNT CASH METER
START	M3 000000	\$ VALUE OF BILLS ACCEPTED
START	M4 000000	DISCOUNT VEND COUNT
START	M5 0000.00	DEBIT CARD CASH METER
START	MP01 .XX	PRICE 1 VEND PRICE
START	MC01 000000	PRICE 1 VEND COUNT
START	MP02 .XX	PRICE 2 VEND PRICE
START	MC02 000000	PRICE 2 VEND COUNT
	↓ ↓ ↓	
START	MP10 .XX	PRICE 10 VEND PRICE
START	MC10 000000	PRICE 10 VEND COUNT
START	MC\$\$ 0000.00	CASH VALUE OF ANY NON SPECIFIED VEND

MODE 2 - TEST VEND

1. Open machine door.
2. Depress the **mode** switch until the display indicates 'MODE 02'.
3. Depress the **START** front panel switch, the display should indicate "THANK YOU" and then scroll the user message signifying that the machine is in the normal user mode.
4. The next vend will be a vend without credit.

MODE 3 - FLUSH CYCLE

1. Open machine door.
2. Depress the **mode** switch until the display indicates **'MODE 03'**.
3. Depress the **START** front panel switch. The machine will then show **"OPT Y/N"**. Use the increase digit switch (coffee strong) to change the Y to flashing.
4. Depress the **START** front panel switch. The machine will then start a series of flush cycles as follows:

Cycle	1	2	3
Chocolate water	Y	Y	Y
Mix. channel water	Y	Y	Y
Brewer water	Y	Y	Y
Soup water	Y	Y	Y

5. Approximate run time for the flush cycle is one and one-half minutes.
6. At the end of the flush cycle the lamp on the cupwell bezel will go out while the display will continue to indicate **'MODE 03'** and the Y that was changed above will reset to N.

FLUSH CYCLE SETTINGS

1. The flush cycle is carried out either by operating mode 3 and automatically every 12 hours. The automatic flush will occur as long as the autoflush enable switch is connected to the logic board and the door is closed. The volume of the water dispensed during the flush cycle is preset during manufacture and should not be adjusted. If you experience problems with the cycle contact technical service at RMI.
2. The automatic flush will operate every 12 hours from the last time that the machine was powered up. If the machine is being used at the end of the 12 hour period it will wait for 10 minutes of complete inactivity before carrying out the cycle.
3. This automatic cycle can be disabled by removing the connector from connector P12 on the logic board, beneath the cover on the inside of the door. It will still be possible to carry out a manual flush using mode 3.

MODE 4 - SET CASH PRICES

1. Open machine door.
 2. Depress the **mode** switch until the display indicates **'MODE 04'**.
 3. Depress the **START** front panel switch, the display will indicate **'PRICE .00'**
 4. Use the **next digit** to move the blinking cursor to the required digit in the display. To increase the selected digit press the **increment digit** switch. The value of the digit will return to **'0'** after **'9'**.
 5. When the desired price has been set on the display, press the **'START'** switch. The display will then indicate **'SELECTION'**.
 6. Depress the selection switches (normal panel buttons) to assign the set price to the drink selections. The selection LED will light up to indicate that the price has been set. Repeat for all selections at the set price.
 7. Depress the **'START'** switch and the display will indicate **'PRICE . '**. To verify the prices depress the appropriate selection switches. The price will be displayed for each selection pressed. The LEDs will remain on until a new mode is entered.
 8. Depress the **'START'** switch and the display will return to **'MODE 04'**.
- ◆ SETTING PRICES TO 0.00 WILL SET A SELECTION TO FREE VEND.
 - ◆ SETTING A PRICE TO 99.99 WILL DISABLE A SELECTION AND CAUSE THE MESSAGE 'MAKE ANOTHER SELECTION' TO APPEAR WHEN THE SELECTION IS PRESSED. THIS IS USEFUL FOR BLOCKING UNUSED SELECTIONS OR DISABLING A SELECTION WHEN IT IS OUT OF ORDER.

MODE 5 - SET DEBIT PRICES

This mode is used to set the prices to be used by a debit card reader. They are a completely separate set of prices from the cash prices. Both cash and debit operation can be available at the same time on the machine. The procedures are identical to **MODE 4**.

MODE 6 - DIAGNOSTICS

1. Open machine door.
2. Depress the **mode** switch until the display indicates **"MODE 06"**.
3. Depress the **START** front panel switch. The scrolling display will have all segments on and all LEDs will be illuminated until MODE 6 is exited.
4. The display will then indicate all the closed switches by switch number, one after another. This facility, along with the list of switches, can be used to locate problems in the machine. See the troubleshooting section in the service section of the manual.
5. At the end of the diagnostics the display will indicate **"MODE 06"**.

MODE 7 - CHANNEL TIMED TEST

1. Open machine door.
2. Depress the **mode** switch until the display indicates **"MODE 07"**.
3. Depress the **START** front panel switch. The display will indicate **"CH 00"**.
4. To select a channel use the **next digit** switch and **increment digit** switches to select the desired channel number.
5. Depress the **START** switch and the selected channel will operate for the normal vend duration time.
6. When the selected channel is finished the display will indicate **"MODE 07"**. See Appendix IV - Heater Circuit.

MODE 8 - CHANNEL CONTINUOUS TEST

1. Open machine door.
2. Depress the **mode** switch until the display indicates **"MODE 08"**.
3. Depress the **START** front panel switch. The display will indicate **"CH 00"**.
4. To select a channel use the **next digit** switch and **increment digit** switches to select the desired channel number.

5. Depress the **START** switch and the selected channel will be turned on. It will stay on until the **START** switch is depressed again. The display will then indicate **"MODE 08"**. See Appendix IV - Heater Circuit.

Note: See the troubleshooting section for additional uses of mode 8.

MODE 9-UPLOAD SETTINGS TO MACHINE

Note: At present the only device capable of being used to upload data to the machine is an IBM compatible computer or another machine.

1. Open machine door.
2. Depress the **mode** switch until the display indicates **"MODE 09"**.
3. Connect the programming device cable to P2 on the control board.
4. Depress the **START** switch before sending the file to the machine control board.
5. The display will remain blank during the file loading time. At the end of the file loading the user message will scroll on the display again.

MODE 10-DOWNLOAD SETTINGS FROM MACHINE

Note: At present the only device capable of being used to download data from the machine is an IBM compatible computer or another machine.

1. Open machine door.
2. Depress the **mode** switch until the display indicates **"MODE 10"**.
3. Connect the programming device cable to P2 on the control board.
4. Depress the **START** switch. This starts sending the file to the external programming device.
5. The display will remain blank during the file sending time. At the end of the file sending the user message will scroll on the display again.

MACHINE TO MACHINE UPLOAD/DOWNLOAD

It is also possible to transfer the settings and data from one machine to another, using a special connecting cable (part # 33784). The procedure is as follows:

1. Connect each end of the cable to the two P2 connectors on each machine control board.
 2. Set machine which has already been set up correctly (machine A), into mode 10.
 3. Set machine to be set up (machine B) into mode 9. Machine B needs to be in an in order condition to receive the download. Depress the **START** switch.
 4. Depress the **START** switch on machine A.
 5. The scrolling display will go blank on machine B. When the scrolling display returns the file transfer is complete.
- ◆ Due to the complexity of the information that is transferred during the upload or download, some precautions must be observed. The information that is required is located on the paper label on the main program chip located on the logic board. The diagram below explains the information contained on the label.

DATE CODE →

052390041590

ORDER # →

16901

CHART # →

0010RHF1

- ◆ If the first date code is 05/23/90 or higher, then only the first three numbers in the chart # in both machines must match for a successful transfer.
- ◆ If the first date code is 02/28/90 or earlier then all eight digits must match exactly for a successful transfer.

MODE 11 - MACHINE CONFIGURATION

1. Open machine door.
2. Insert security key into the service key switch, turn the switch to the "on" position and then back to the "off" position. This allows the key to be removed and prevent it being left in the machine in error.
 - ◆ The correct function of the key switch is: on then off - the key should always be in the position where key can be removed.
3. The display should indicate "MODE 11".
4. Depress the **START** switch. The display will indicate "CONFIG H/B/C". The "H" should be flashing to indicate that the machine is set up as a 203 hot drink machine.
5. If the "H" is not flashing, after having just installed a new control board for example, press the **change digit** switch until it is. Then depress the **START** switch. The machine will then jump automatically to mode 16 to load the default values appropriate for the 203 machine (see **MODE 16**).
6. If the "H" was flashing correctly continue with the configuration by depressing the **START** switch.
7. The machine will then advance through a series of four questions. Each selection is made by depressing the **change digit** switch until the "Y" (yes) or "N" (no) is flashing and then activating the selection by depressing the **START** switch. The flashing character indicates the selected choice. The following questions are indicated on the display:

	FLASHING Y	FLASHING N
'OPT 1 Y/N'	Brewed regular coffee	No brewer-FD coffee
'OPT 2 Y/N'	Brewed decaf coffee	No brewer-FD decaf.
'OPT 3 Y/N'	Espresso	Soup
'OPT 4 Y/N'	Fresh brewed tea	FD tea or no tea

8. When the **START** switch is pressed for the final question the display will indicate "MODE 11".

Note: It is important to return to the "MODE 11" on the display to ensure that the new values are loaded.

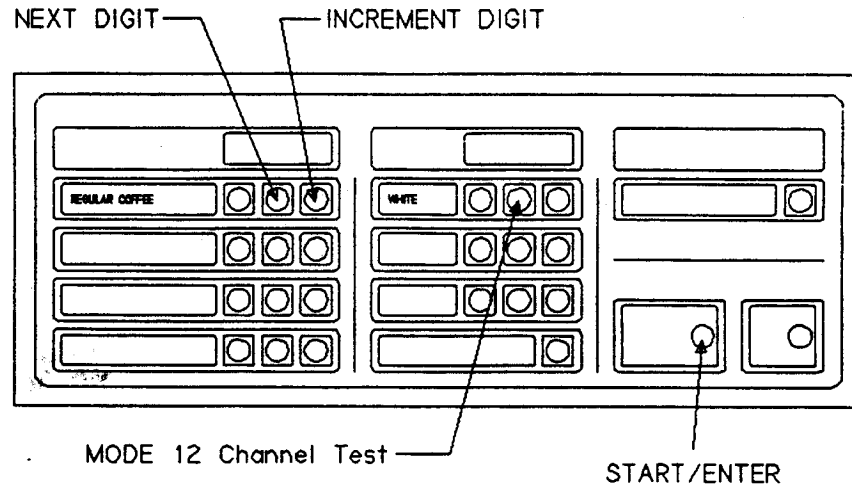

MODE 12 - SET TIME CHANNELS

1. Open machine door.
2. Insert security key into the service key switch, turn the switch to the 'on' position and then back to the 'off' position.
3. Depress the **mode** switch until the display indicates 'MODE 12'.
4. Depress the **START** switch. The display will indicate 'CH 00'.
5. To select a channel use the **next digit** switch and **increment digit** switches to select the desired channel number. See figure above for location of switches.
6. Depress the **START** switch and the start time will be displayed in the following format - 'START 00.0'. This is the time from the beginning of the vend cycle to when the channel starts.
7. To change the start time the **next digit** switch can be depressed to move the flashing character to the digit to be changed and the **increment digit** switch depressed to increase the value of the digit.
8. When the required start time has been set, depress the **START** switch. This will change the previous start time to the new start time and advance to display the duration time. The display will be in the following format - 'DUR 00.00'.
9. The duration time can be changed by use of the **next digit** and **increment digit** switches.
10. When the required duration time has been set, depress the **START** switch. The new duration time will replace

the old time. If the channel has a modifier the display will indicate 'MOD 0.00'. If there is no modifier the display will indicate 'MODE 12'.

11. The duration sets the ingredient throw for the medium strength of selection e.g. regular coffee. The modifier value is the percentage increase and decrease in ingredient throw for the strong and weak selections on the selection panel. The modifier is set by means of the **next digit** and **increment digit** switches. By depressing the **START** switch the new modifier will replace old one. The display will then indicate 'MODE 12'.
 12. The selected channel can be tested by depressing the **CHANNEL TEST** switch (regular white). The channel will be turned on for the normal vend duration. The display will indicate 'MODE 12'.
- ◆ Each channel to be tested must be 'ENTERED' before it is tested - otherwise the test will return to the last channel tested.

Note: It is important to return to the 'MODE 12' on the display to ensure that the new values are loaded.

MODE 13 - SET OPTIONS

1. Open machine door.
2. Insert security key into the service key switch, turn the switch to the 'on' position and then back to the 'off' position.
3. The display should indicate 'MODE 13'.
4. Depress the **START** switch. The machine will then advance through a series of questions and options. Each Y/N selection is made by depressing the change digit switch until the 'Y' (yes) or 'N' (no) is flashing and then activating the selection by depressing the **START** switch. The following questions are indicated on the display:

'FORCE Y/N' - Y - Forced i.e. User must make a vend before change is returned
N - Normal

'FREE Y/N' - Y - Free vend enabled on all selections
N - Normal prices apply

'MS1600 Y/N' - Y - European Executive changer installed
N - US changer installed

'ESCROW Y/N' - Y - Bill validator will escrow any bill that takes the credit above the vend price. No further bills will then be accepted. If the coin reject is pressed the bill will be returned.
N - Bills are stacked immediately.

'MULTI Y/N' - Y - More than one vend can be made before change is returned.
N - Single vend - Change is returned immediately.

'DISC .00' Any selection set up to have a discount (see mode 14) will be discounted by the factor set in this display. The discount price is obtained by multiplying the vend price by the discount factor e.g. 50¢ x .80 = 40¢. The discounted price will be in effect when the discount switch is operated.

'FREE CT 00' - This option allows a free drink after a given number of vends. The number in the display can be set between '01' (every vend) and '255' (every 255th vend is free). If the number is left at '00' no free vends will be given.

'VOLUME .00' Not used on the 203 hot drink machine.

'VOL D .00' Not used on the 203 hot drink machine.

5. Depress the **START** switch. The display will indicate 'PRICE1 .XX'. This is the price setting for the first price line. There are ten price lines that can be set to the required values. The control will then increment the count every time a vend is made at that price (or an equivalent price obtained by discounting a higher price).
6. Set the required price using the **Increment digit** and **next digit** buttons.
7. Depressing the **START** switch will increment through the 10 price line values:

'PRICE2 .XX'

'PRICE9 .XX'

'PRICE0 .XX'

Each price line can be set to a different value. Set any unused prices to .00.

8. Depressing the **START** switch completes the selection and returns to the beginning of the mode. The display will indicate 'MODE 13'.

Note: It is important to return to the 'MODE 13' on the display to ensure that the new values are loaded.

- ♦ The first available price line set to .00 will record all **MODE 2** test vends, all 100% discount vends and all **FREE CT** (winner) vends.

MODE 14 - SET DISCOUNT BITS

1. Open machine door.
2. Insert security key into the service key switch, turn the switch to the 'on' position and then back to the 'off' position.
3. Depress the mode switch until the display indicates 'MODE 14'.
4. Depress the START switch. The display will indicate 'SELECTION'.
5. All previously set discounts will be reset. Depress the selection switches (normal panel buttons) to change the drink selections to 'discount. The selection LED will light up to indicate that it is discounted. If the selection is pressed again the LED will go out again to indicate that it is not discounted.
6. Depress the START to complete the selection. The display will indicate 'MODE 14'.

NOTE: Changing the options in MODE 11 may require resetting the discount assignments.

- ◆ Entering MODE 14 and pressing START twice will clear all selections previously set for discount.

MODE 15 - NOT USED ON THE 203 HOT DRINK MACHINE

MODE 16 - LOAD STANDARD SETTINGS

1. Open machine door.
2. Insert security key into the service key switch, turn the switch to the 'on' position and then back to the 'off' position.
3. Depress the mode switch until the display indicates 'MODE 16'.
4. Depress the START switch and the display will indicate 'MODE 16' again.
5. In order to prevent accidental loading of the standard times and settings, it is necessary to enter a code number or password. Using the increment digit and next digit switches change the '16' to '27' and then depress the START switch. The display will go blank.

- ◆ Changing the '16' to a '27' should be considered a password that is the only way to reload the factory standard times. To confirm that MODE 16 was properly done turn power off and back on. If configuration and the values in MODES 11,12 and 13 remain the same, then the reload was correctly done.

6. When initialization and loading of the standard values is complete the display will scroll the user message again.

7. Return to mode 11, recheck configuration and set the machine options.

- ◆ If you have been supplied with a 'CUSTOM CHIP' (indicated by a F in the fourth position of the of the CHART # as shown in the diagram on the page describing the EPROM label) you are reloading the times and settings provided when the 'CUSTOM CHIP' was created.

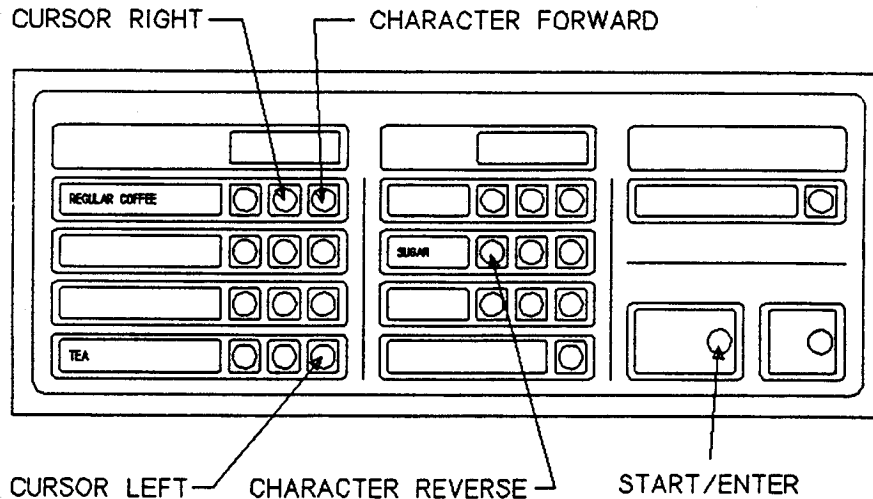

MODE 17 - PROGRAMMING USER MESSAGE

1. Open machine door.
2. Insert security key into the service key switch, turn the switch to the 'on' position and then back to the 'off' position.
3. Depress the mode switch until the display indicates 'MODE 17'.
4. Depress the START switch. The first nine characters of the user message will be displayed with the cursor (flashing character) at position eight and a special start character (☒) at position one.
5. The message can now be changed by moving through the message to the characters that need changing and then selecting from the list of characters and symbols.
6. **CURSOR RIGHT -**
Switch 'A' (coffee regular) moves the cursor to the right in the message. Depressing switch 'A' for less than one second will move the cursor right one character at a time. If depressed longer the rate of movement will speed up.
7. **CURSOR LEFT -**
Switch 'B' (tea strong) moves the cursor to the left in the message. Depressing switch 'B' for less than one second will move the cursor right one character at a time. If depressed longer the rate of movement will speed up.
8. **CHARACTER FORWARD -**
Switch 'C' (coffee strong) controls the characters at the cursor location. Depressing switch 'C' for less than one second will move forward through the character set one character at a time. If depressed longer the rate of movement will speed up. When a character has been correctly set simply move on to the next character.

9. CHARACTER REVERSE -

Switch 'D' (sugar weak) also controls the characters at the cursor location. Depressing switch 'D' for less than one second will move backward through the character set one character at a time. If depressed longer the rate of movement will speed up.

10. The (☒) character indicates the left and right boundaries of the user message.

11. The (⏏) character must be entered to indicate the end of message to be displayed. Otherwise the display message would ignore the boundary character and may scroll some characters that do not belong to the character set.

12. The message program mode should be exited by depressing the mode switch only.

13. VALID CHARACTER SET -

The following characters are available:

A through Z
0 through 9

\$ ' < > * + , - . / ? ⏏

A blank is represented by a flashing underline _

- ◆ Approximately 85 spaces including blanks and punctuation are available for a user message to be loaded into the scrolling display. For best results leave 5-6 spaces blank at the beginning of your message. Doublecheck for correct spelling - errors in the middle of the message are difficult to correct.

APPENDIX I: 203 MACHINE - CHANNEL NUMBERS & STANDARD TIMES

NOTE: Times shown below are for standard 7 oz. vend

CHANNEL #	DESCRIPTION	START	DURATION	MODIFIER	CUSTOMER SETTINGS		
					S	D	M
02	Vend time	0.0	25.00				
03	Cup drop	0.0	1.40				
04	Large grinder - reg.	0.0	0.75	0.25			
06	Loose Ground - reg coffee	0.0	1.35	0.25			
07	LG/small grinder - decaf	0.0	1.30	0.25			
08	Brew motor - coffee	3.0	22.00				
09	Water - coffee brew	4.1	1.90				
10	Water - coffee brew espresso	4.1	1.11				
11	Open cylinder delay - coffee brewer	7.4	1.00	0.00			
12	Pressure relief delay - coffee brew	14.0	2.00				
13	Make up water - coffee brew	12.0	2.30				
14	Whitener auger - coffee brew	13.0	0.90	0.30			
15	Sugar auger - coffee brew	12.0	2.21	0.15			
16	Sugar substitute auger - coffee brew	12.0	0.40	0.25			
17	Whipper - coffee brew espresso	8.6	10.00				
18	Water - FD coffee	2.8	6.00				
19	Water - FD tea (version 2 yellow)	2.8	6.00				
20	Regular coffee FD auger	5.8	2.80	0.25			
21	Decaf FD auger	5.8	2.80	0.25			
22	Coffee FD gourmet auger	5.8	2.80	0.15			
23	Whitener auger - coffee FD	5.8	0.90	0.30			
24	Sugar auger - coffee FD	5.8	2.50	0.15			
25	Sugar substitute auger - coffee FD	5.8	0.40	0.25			
26	Water - tea brew	0.5	8.80				
27	Tea FD auger	5.8	1.50	0.15			
28	Tea brew auger	0.5	0.25	0.15			
29	Brewer motor - tea	15.0	1.75				
30	Whitener auger - tea FD	5.8	0.40	0.30			
31	Sugar auger - tea FD	5.8	2.00	0.15			
32	Sugar substitute auger - tea FD	5.8	0.90	0.25			
33	Water/whipper - chocolate	1.0	5.00				
34	Chocolate auger	2.0	3.86				
35	Water/whipper - soup	1.0	7.20				
36	Soup auger	2.0	4.60				
37	Water - white espresso	7.5	1.50	0.25			
38	White auger - espresso	9.0	1.20	0.25			
39	Clean cycle - total time	0.0	25.00	*			
40	Clean cycle water - soup	12.0	4.00	*			
53	Clean water - chocolate	20.0	4.00	*			
56	Whipper - coffee brew	8.6	0.00				
57	Whipper - coffee FD	6.0	0.00				
60	Clean water FD	17.0	2.00	*			
61	Clean cycle water - coffee brew	5.0	2.50	*			
62	Clean cycle water - tea brew	16.7	0.10	*			
63	Clean cycle water - tea brew	0.0	1.75	*			
64	Clean cycle water - coffee brew	2.0	22.00	*			
65	Clean cycle - coffee whipper	8.0	2.00	*			
66	White auger - tea brew	4.5	0.40	0.30			
67	Sugar auger - tea brew	2.5	2.00	0.15			
68	Sugar substitute auger - tea brew	2.5	0.90	0.25			
71	Whipper - gourmet coffee	6.0	0.00				

* Denotes cleaning cycle channels

APPENDIX II: 203 SWITCH NUMBERS

Switch #	Description	(Selection panel)	Selector membrane switch terminals
00	Gourmet, low	.	1 & 2
01	Gourmet, medium	.	1 & 3
02	Tea, low	.	1 & 4
03	Coffee, low	.	1 & 5
04	Coffee, medium	.	1 & 6
05	Coffee, high	.	1 & 7
06	Decafe, low	.	1 & 8
07	Decafe, medium	.	1 & 9
08	Decafe, high	.	10 & 11
09	Gourmet, high	.	10 & 12
10	Tea, high	.	10 & 13
11	Sugar, low	.	10 & 14
12	Sugar, medium	.	10 & 15
13	Sugar sub, low	.	10 & 16
14	White, low	.	10 & 17
15	White, medium	.	10 & 18
16	White, high	.	19 & 20
17	Sugar, high	.	19 & 21
18	Sugar sub, high	.	19 & 22
19	Chocolate	.	19 & 23
20	Tea, medium	.	19 & 24
21	Soup	.	19 & 25
22	Sugar sub, medium	.	19 & 26
23	Start	.	19 & 27
24	Cancel	.	28 & 29
25	Discount vend		
26	Flush interlock		
27	Waste and grounds bucket-AC Present		
28	Cup present		
29	Security key		
30	Mode		
31	-		
32	-		
33	Brewer water		
34	Brewer cycle		
35	Brewer delay		
36	Heater thermostat #1	} Logic level thermostats only See Appendix IV	
37	Heater thermostat #2		
38	-		
39	Water present - Float (Version 1)		
40	Water present - Probe (Version 2 - See pg 3.20)		

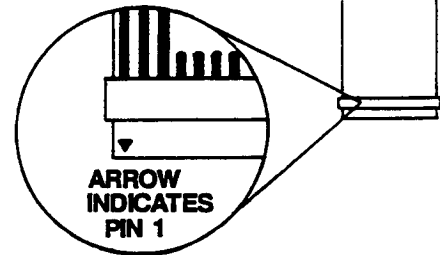
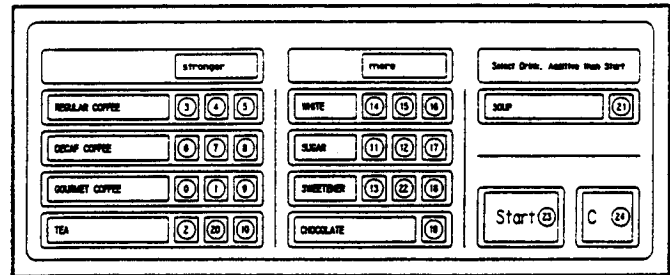

APPENDIX III: "OUT OF ORDER" CODES

Code	Out of Cups 01	No Water 02	Heater Failure 04	EPROM Mismatch 10	No AC (Float high) 20
01	Out of cups				
02		No Water			
03	Out of cups	No Water			
04			Heater Failure		
05	Out of cups		Heater Failure		
06		No Water	Heater Failure		
07	Out of cups	No Water	Heater Failure		
10				EPROM Mismatch	
11	Out of cups			EPROM Mismatch	
12		No Water		EPROM Mismatch	
13	Out of cups	No Water		EPROM Mismatch	
14			Heater Failure	EPROM Mismatch	
15	Out of cups		Heater Failure	EPROM Mismatch	
16		No Water	Heater Failure	EPROM Mismatch	
17	Out of cups	No Water	Heater Failure	EPROM Mismatch	
20					No AC (Float high)
21	Out of cups				No AC (Float high)
22		No Water			No AC (Float high)
23	Out of cups	No Water			No AC (Float high)
24			Heater Failure		No AC (Float high)
25	Out of cups		Heater Failure		No AC (Float high)
26		No Water	Heater Failure		No AC (Float high)
27	Out of cups	No Water	Heater Failure		No AC (Float high)
30				EPROM Mismatch	No AC (Float high)
31	Out of cups			EPROM Mismatch	No AC (Float high)
32		No Water		EPROM Mismatch	No AC (Float high)
33	Out of cups	No Water		EPROM Mismatch	No AC (Float high)
34			Heater Failure	EPROM Mismatch	No AC (Float high)
35	Out of cups		Heater Failure	EPROM Mismatch	No AC (Float high)
36		No Water	Heater Failure	EPROM Mismatch	No AC (Float high)
37	Out of cups	No Water	Heater Failure	EPROM Mismatch	No AC (Float high)

NOTE: If a code other than one of the above shows in the scrolling display, MODE 11 is probably configured incorrectly and should be checked immediately. Code M04 will not appear in machines with direct control thermostats - see Appendix IV - Heater Circuit Wiring

APPENDIX IV - HEATER CIRCUIT WIRING

Changes have occurred in the heater circuit wiring in the AP 203. It is important to understand the type of control circuit that is operating through the two thermostats mounted on the tank lid. Since there are two different circuits, each will be given a name and explained in turn.

The original style - **LOGIC LEVEL THERMOSTATS** use low voltage data lines generated by the logic board and sent to the tank mounted thermostats to determine the temperature of the water in the tank. The logic board then directs the motor control board to turn on the appropriate heater. Once the thermostats are satisfied the motor control board is directed to turn off the heaters. This monitoring circuit will also create an "OUT OF ORDER M04" or "PLEASE WAIT" message on the scrolling display when both thermostats are calling for heat on power-up. Removing one wire from the front thermostat will simulate the thermostat being satisfied and mislead the logic board, restoring the standard scrolling message. Replacing the wire will then allow the machine to continue heating until the entire tank is hot. Logic level thermostats can be identified by: thin gauge wire connected to the thermostat terminals and the absence of a jumper from the right terminal of the front thermostat to the center terminal of the rear thermostat. See FIGURE 2.07.

The current style - **DIRECT CONTROL THERMOSTATS** are found in AP 203 merchandiser with S/N 37075 or higher. Direct control thermostats can be identified by: the large gauge wire going to the thermostats and the presence of a jumper wire from the right terminal of the front thermostat to the center terminal of the rear thermostat. Also present is a jumper wire connecting the wires marked T1-A and T1-B. This jumper wire connects two former logic level thermostat wires to provide a constant 110 volts at the P8-2 and P8-3 terminals on the motor control board. This constant voltage is supplied to the Common (center) terminal of the front thermostat and directs the voltage to the top heater or the rear thermostat dependent upon the temperature of the water in the tank. This allows direct control of the heater elements by the thermostats. By leaving the other pair of former logic level thermostat wires not connected, the "OUT OF ORDER M04" or "PLEASE WAIT" message should never appear. See FIGURE 2.08.

- ◆◆ An error in Version 1 software may prevent the large grinder from operating in MODES 7 and 8. This appeared soon after the change to the heater circuit wiring. This is due to the protection written into the software to prevent incorrect heater and grinder operations. This error is corrected in the final revision of Version 1 software identified as 001SP. Testing of the large grinder can be done by using the MODE 12

CHANNEL TEST BUTTON. If it is necessary to operate the grinder in MODE 7 or 8, power down, disconnect one side of the jumper wire from the wire marked T1-A or T1-B, restore power and test. Wires T1-A and T1-B are the former logic level thermostat wires and are located directly above the heater tank. This disables the heater circuit and allows the grinder to be tested in MODE 7 or 8. The wire must be reconnected after the test.

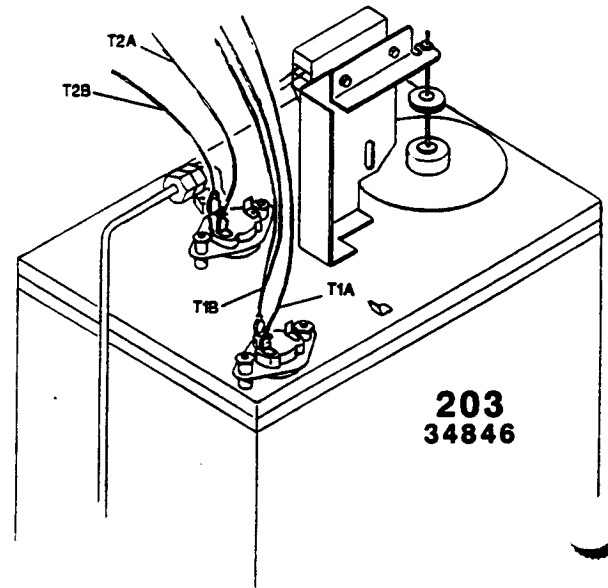

FIGURE 2.07

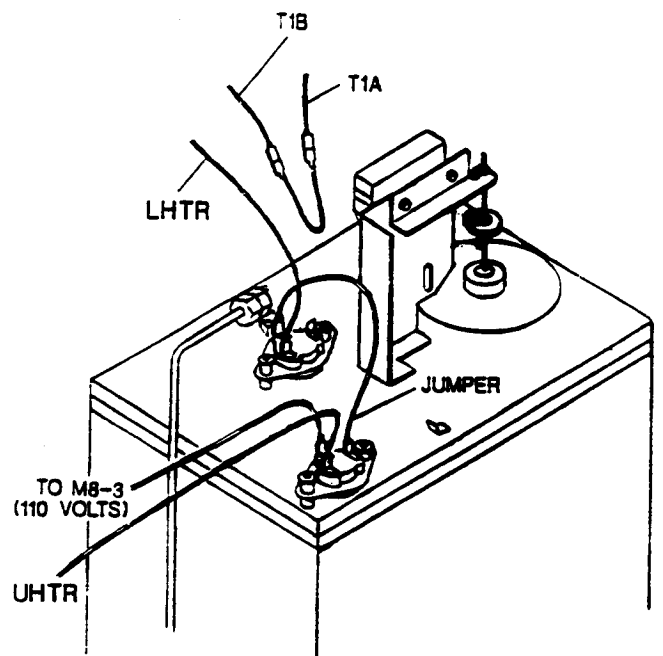

FIGURE 2.08

SERVICE INDEX

SANITIZING AND CLEANING PROCEDURES	3.01
FUNCTION OF THE BREWER	3.02
ADJUSTMENT OF THE BREW CABLE	3.06
WATER SYSTEM	3.08
WATER DELIVERY SYSTEM	3.09
THE CANISTER RACK	3.10
CUP DELIVERY SYSTEM	3.12
CHANGING TO A 9 OZ CUP	3.13
LARGE GRINDER	3.16
ZERO ADJUSTMENT FOR THE LARGE GRINDER	3.17
ZERO ADJUSTMENT FOR THE MINI-GRINDER	3.18
TROUBLESHOOTING	3.20
VERSION 2 SOFTWARE CHANGES	3.20
TROUBLESHOOTING CHART	3.21
LOGIC BOARD REPLACEMENT DIRECTIONS	3.27
MOTOR CONTROL BOARD PIN CONNECTIONS	3.28
LOGIC CONTROL BOARD PIN CONNECTIONS	3.29
LED PRINTED CIRCUIT BOARD PIN CONNECTIONS	3.29
SCHEMATIC VERSION 1 SOFTWARE	3.30
SCHEMATIC VERSION 2 SOFTWARE	3.31

SANITIZING AND CLEANING PROCEDURES FOR AP 203

EACH VISIT

1. Fill cup cabinet with cups to required level. Wipe interior and exterior of cup cabinet.
2. Replenish all canisters and/or bean hoppers. Clean any spills. Wipe the lids of the canisters with a damp towel. Dry all damp surfaces.
3. Run the flush cycle (MODE 3) which will take approximately 1 1/2 minutes. Depress the mode switch until the display indicates "MODE 03". Depress the START front panel switch. The machine will then show "OPT Y/N". Use the coffee strong button to change the Y to flashing. Depress the START front panel switch. The machine will then start a series of flush cycles.
4. After the completion of the flush cycle, cycle brewer to the dump position by depressing the front left roller switch on the brewer until the brewer will continue to run on it's own. When the brewer reaches the forward position, turn off the control circuit breaker. Remove the splash guard from the front of the brewer. Using the spray hose, rinse any loose grounds from the brewer and the splash guard. Replace splash guard and restore power to machine.
5. Remove the humidity bar (CAUTION-bar is hot) and the commodity chutes from the trough. Check all canister spouts and commodity chutes for blockages. Rinse commodity chutes and trough with spray hose to remove any residue. If necessary the trough can be scrubbed with a damp cloth followed with a rinse of hot water from the spray hose. DO NOT SCOUR THE TROUGH WITH ANY ABRASIVE MATERIAL! This can result in a poor wash of the trough and poorly mixed ingredients in a drink, or residue in the trough. Carefully dry the commodity chutes and reinstall the humidity bar and the commodity chutes.

6. Using warm water and detergent clean other interior surfaces, wipe with a damp cloth and wipe dry.
7. Remove cupwell, grate and vend door, clean with hot water and detergent. Rinse with clear water and dry with clean cloth or paper towel. Wipe inside of door and clean vend door guides. Replace cupwell, grate and vend door in machine.
8. Remove disposable bag containing spent coffee grounds and rinse bucket with hot water and replace liner. Empty and scrub waste bucket. Rinse with anti-bacterial solution. DO NOT rinse bucket after anti-bacterial solution is used- this will defeat its purpose. Clean floor of machine with hot water and wipe dry. Replace buckets in machine making sure both floats are hanging free in the buckets.
9. Before closing door access MODE 2 and press START to set one test vend to check for proper operation. Lock vendor door, make a selection, clean exterior of door and cabinet.

QUARTERLY

1. Cycle brewer to the 'dump' position, spray with rinse hose to remove any excessive grounds. Disconnect the brewer cable from the carriage by gently pushing the carriage to the rear and lifting the cable out of its slot. Lift the lower brewer assembly latch and remove the bottom half of the brewer. Place in a bucket of hot water to allow it to soak.
2. Remove steam duct, exhaust hose, and metal screen between exhaust motor and mounting plate. Rinse clean with hot water. Dry with a clean cloth and return to position.
3. Disassemble chocolate whipper housing and mixing bowl by spreading the wire clips and pulling straight out. Clean parts with hot water. Clean and inspect the whipper base and impeller for wear. Reassemble making sure the large 'O' ring is positioned correctly inside the whipper housing.
4. Disconnect all hoses from mixing bowls, channel and delivery spout and clean with hot water. Replace hoses.
5. Remove lower half of brewer from bucket and rinse well with hot water and install on main brewer assembly. Reconnect cable. Inspect brew filter, screen and gasket for wear, rips or obstruction of the filter or screen.
6. Remove cover of coffee delivery chute and clean chute and cover with a dry cloth. Replace cover.
7. Clean coin mechanism acceptor with a damp cloth and wipe dry.
8. Perform EACH VISIT procedure above.

FUNCTION OF THE BREWER IN AN AP 203

The heart of the AP 203 Hot Drink Merchandiser is the open cylinder brewer. It has been "time proven" and "experience improved". It is simple, lightweight, easy to clean and easy to service.

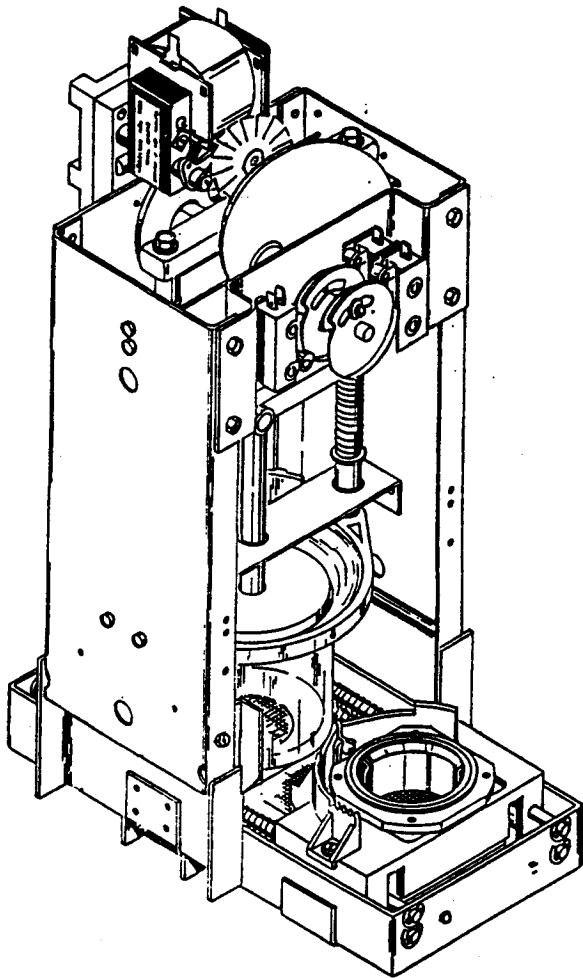

FIGURE 3.1

HOW THE BREWER WORKS

The word "front" used in this description refers to the parts of the brewer nearest the observer, standing before the open cabinet.

All AP 203 fresh brew machines have the brewer stopping at the same point. The brewer is stopped with the brew carriage aligned directly over the brew filter and under the coffee delivery chute. When a brewed coffee drink is selected, the ground coffee (from a grinder or a LG canister) is delivered

directly to the brew chamber via the stainless coffee delivery chute.

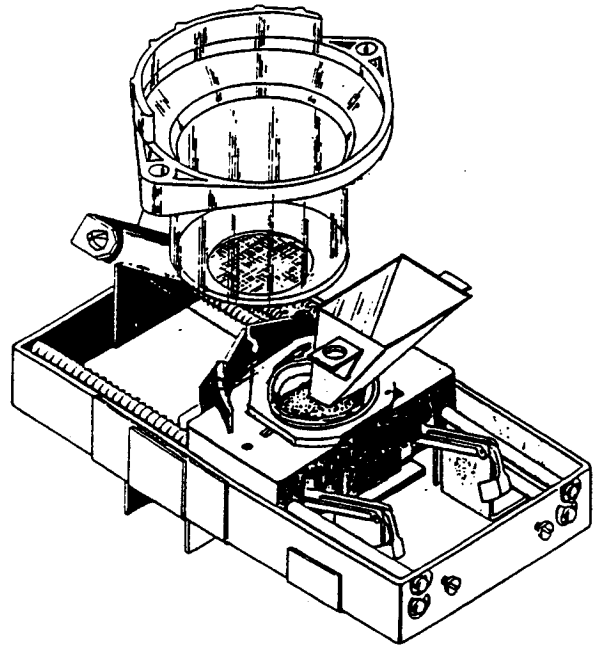

FIGURE 3.2

The brewer starts at the time determined by channel 8 (typically 3.00 seconds). When the brewer starts the cable will begin to retract the brew carriage towards the rear of the base assembly. Once the first switch rides up on the high side of the front cam, the brewer will continue to run until it falls back into the valley.

The brew carriage will continue back until it is slightly behind the clear brew cylinder when the brew cylinder starts its downward motion. At the proper time the cable is slackened slightly to allow the brew carriage to self-align with the cylinder. As the cylinder clamps down on the brew chamber seal, the roller of the second switch should be in the valley of the cam and the switch will send a signal to the logic board that it is the proper time to deliver water to the brewer. The brew water valve is energized for the duration determined by channel 9. The cylinder is held against the brew chamber seal by the springs on the cylinder support rods. The middle cam will also signal the logic board just before the piston has contacted the cylinder and the window for delivery of brew water has closed. The water will flow into the cylinder down through the grate in the bottom of the cylinder into the coffee filled brew chamber. The grate in the bottom of the cylinder

prevents the coffee grounds from floating up into the cylinder.

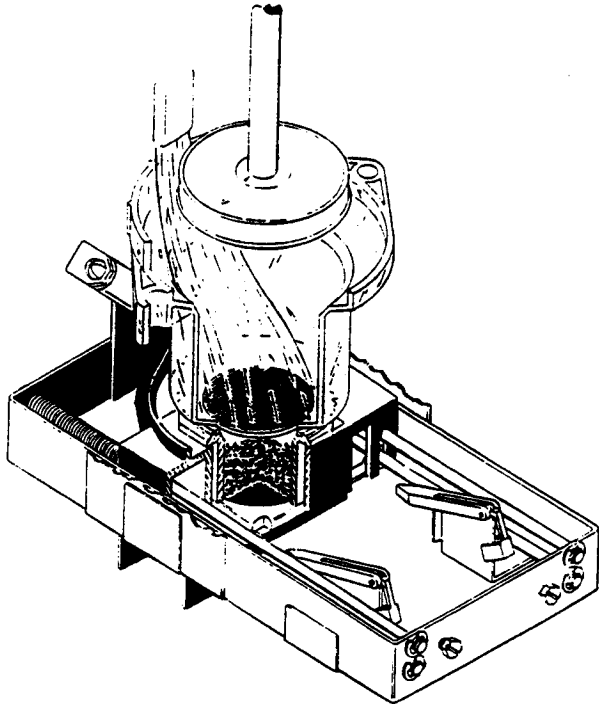

FIGURE 3.3

As the cycle continues, the piston is moved down into the cylinder by a large cam on the main shaft. Air trapped between the piston and the water in the cylinder is quickly heated by the hot water and begins to expand. The downward motion of the piston, plus the pressure of the expanding air, forces the water through the coffee grounds in the brew chamber and out through the delivery funnel to the trough.

The heated, compressed air follows the water through the grounds forcing the remaining water out of the grounds and drying the grounds. If a drink has been selected that includes a strength delay, the roller of the third switch falling into the valley of the rear cam will signal the logic board that the brewer is in the correct position to apply any strength delay set in channel 11. The piston will then stop once it seals the cylinder. This increases the water to coffee contact time for increased extraction. The length of this delay is controlled by the duration and modifier set on channel 11. This delay is also added to the light and sugar motor start times to compensate for the later delivery of the coffee to the trough. If a duration is set in channel 12 (pressure relief delay), then the roller of the third switch riding back up on the high side the rear cam will signal the logic board to activate the pressure relief delay.

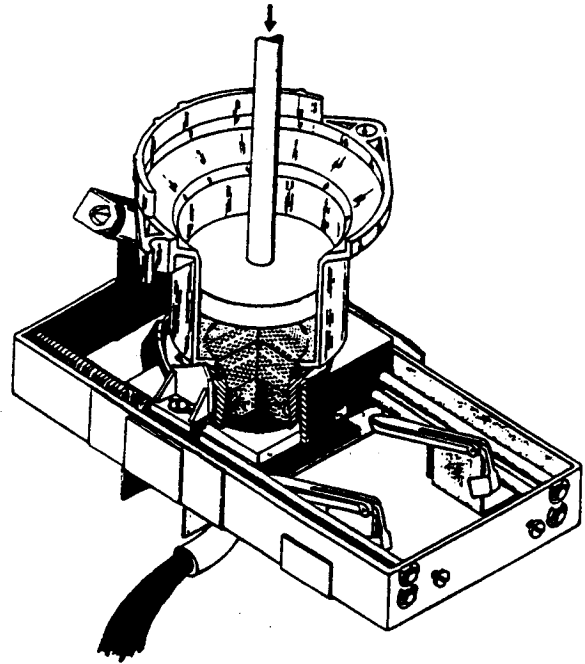

FIGURE 3.4

This pressure relief delay allows any built-up back pressure in the brew chamber and cylinder to dissipate through the bed of grounds.

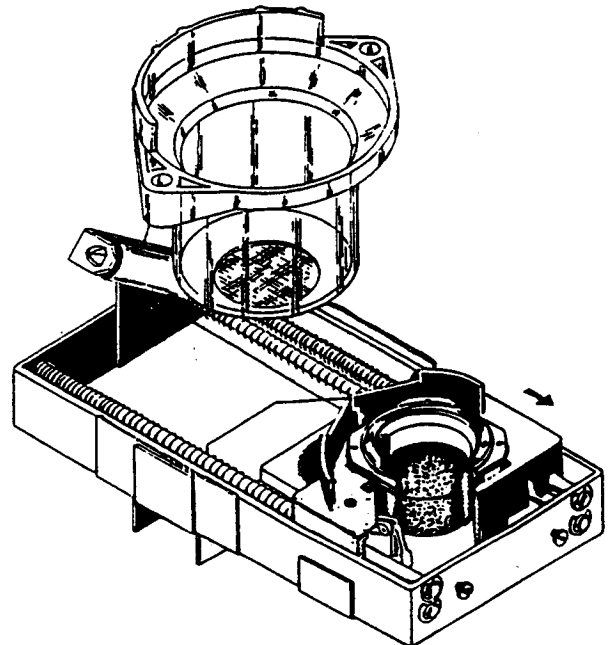

FIGURE 3.5

After the pressure relief delay or after the water has passed through the bed of grounds, the brewer starts the portion of the cycle that empties the brewer of spent grounds and resets the brewer for the next vend. The looseness in the brew carriage cable is removed and the piston and cylinder are raised far enough to allow the brew carriage to pass under the cylinder.

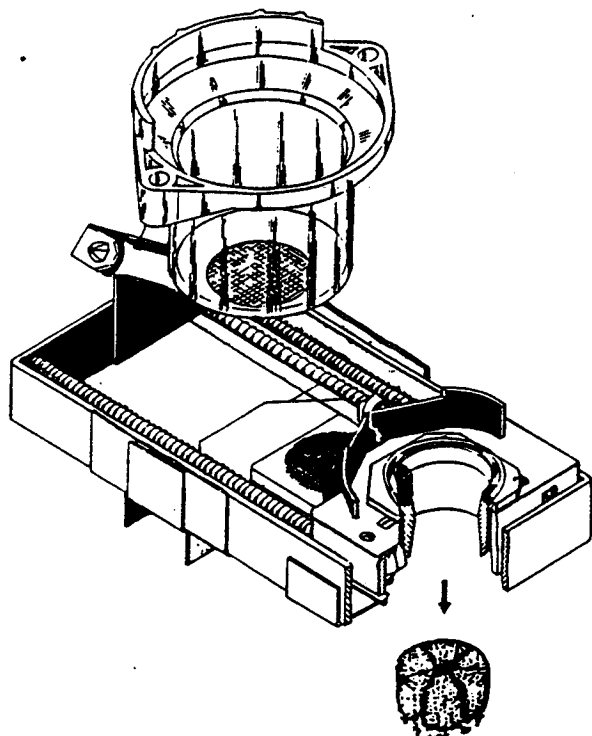

FIGURE 3.6

The cable is then unwound, controlling the forward motion of the brew carriage, which is being forced forward by the carriage rod springs. As the brew carriage passes over the two white pawls in the base assembly, the two ears on the sides of brew chamber lift the brew chamber allowing the brew chamber to ride up the pawls. As soon as the ears are free of the support of the pawls, the brew chamber snaps downward, dislodging the spent grounds into the grounds bucket.

The cable will then begin to retract the brew carriage toward the rear of the base assembly until the brew chamber is directly over the filter and under the delivery chute. At this point the roller of the front switch will fall into the valley of the front cam, signalling the logic board to stop the brewer. This is the standby position and the brewer will remain in this position awaiting the next vend.

AUTOMATIC PRODUCTS 203 V5.0

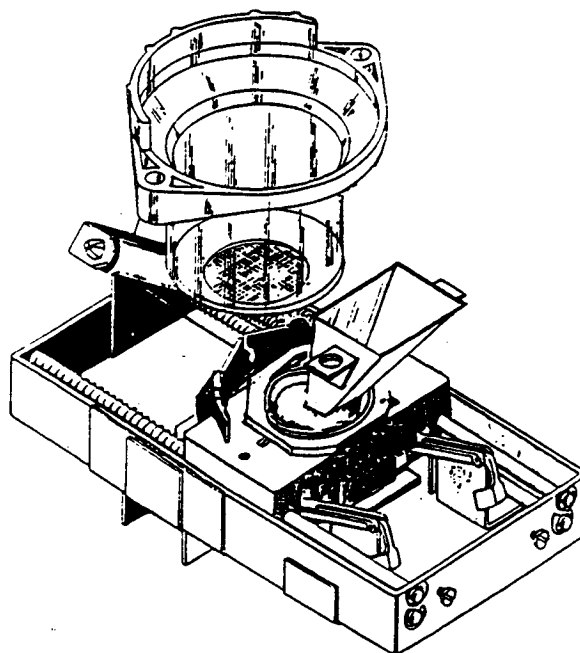

FIGURE 3.7

BREW CARRIAGE AND CABLE ADJUSTMENT

The horizontal movement of the carriage is caused by the springs in the base assembly. The action of the springs is controlled by the brew carriage cable assembly. The cable is wrapped on a spool and wound and unwound to move the carriage in synchronization with the other movements of the brewer. The cable spool is controlled by a gear segment driven by the rear cam of the main shaft assembly. The shape of the cam determines when the cable is wound and unwound.

When the cylinder is pressing down on the brew chamber, the cable should be slack. Just as the brew cylinder begins to raise the cable tightens, to prevent the carriage from jumping forward as the cylinder clears the alignment shoulder of the brew carriage. As soon as the cylinder is high enough to clear the carriage, the cable is unwound and the carriage moves forward to dump the spent grounds. After the spent grounds are dumped, the cable again winds on the outer spool and pulls the carriage to the stopping position.

The cable is attached to the outer section of the spool with a cotter pin. The inner portion of the spool is connected to a shaft and a small gear. The gear is rotated by a pivoting segment gear driven by a cam follower riding on the edge of the rear cam of the main shaft assembly. The inner and outer sections of the cable spool have matching teeth which provide a positive mesh but allow for adjustment. When the

two parts are assembled, they are secured by a screw and washer which prevent them from being disengaged.

ADJUSTMENT OF THE BREW CABLE

Operate the brewer through a complete cycle and observe that:

1. The alignment shoulder of the carriage is slightly behind the rear vertical edge of the brew cylinder as the cylinder starts down.
2. The cable goes slightly slack just before the cylinder contacts the surface of the brew chamber gasket.
3. After brewing, the carriage moves forward all the way to the dump position.

If all three of these conditions are not met, then a cable adjustment should be made using the following procedure:

1. Depress the front left switch on the top of the brewer and allow the brewer to cycle to the brew position. Turn off power and lift the latch pin in right rear of the brewer and swing the brewer away from the water tank.

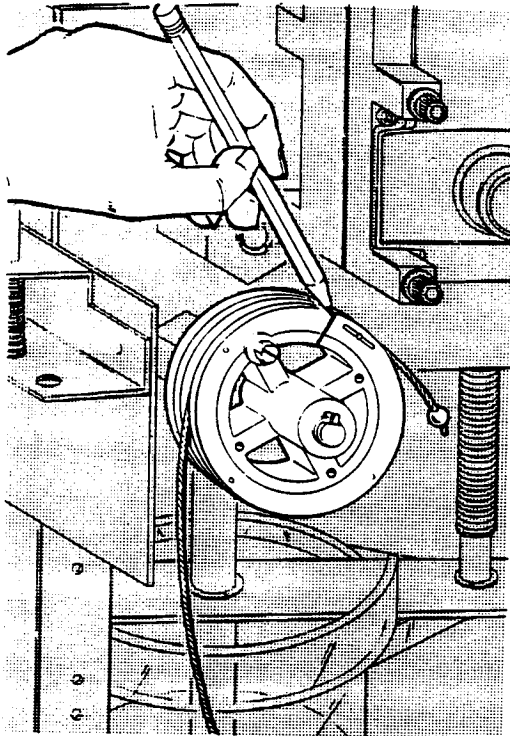

FIGURE 3.8

2. Mark the inner and outer section of the cable spool with a pencil line across both pieces to provide a reference mark. See FIGURE 3.8.
3. Restore power and cycle the brewer to the dumping position and turn off the power.
4. If the carriage was not correctly behind the cylinder and is being forced back out of the way or the cylinder is resting on top of the alignment shoulder of the brew carriage (see FIGURE 3.9) and causing the brew water to leak from between the cylinder and the brew chamber, then an adjustment of only one or two teeth to shorten the cable is needed - go to step 9. If the original adjustment has been lost, then a 'scratch' adjustment will have to be made - continue to step 5.

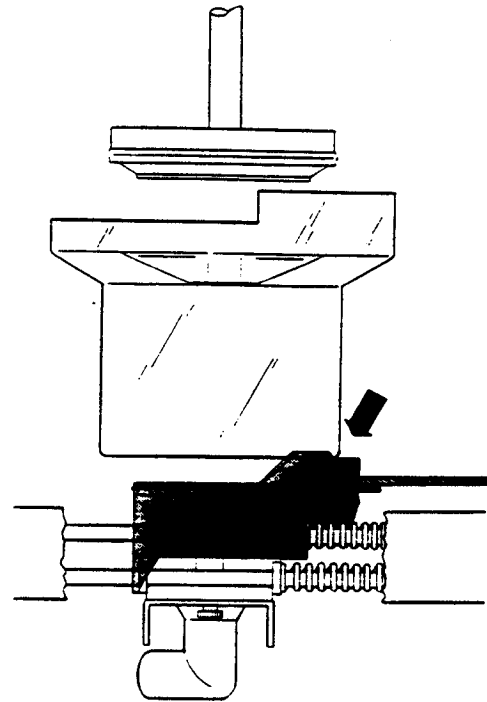

FIGURE 3.9

5. Confirm that the cam follower is in the deepest valley of the rear cam (See Figure 3.11) by cycling the brewer to this position. This position of the cam and follower guarantees that the brewer is in the dump position.
6. Feed the cable down between the roller and the support bracket and towards the front of the brewer. Slip the cable into the slot on the rear of the carriage.
7. Wind the cable clockwise on the outer spool until the carriage is pulled back from the inner face of the base assembly (See Figure 3.10) 1/8 to 3/16 inch.

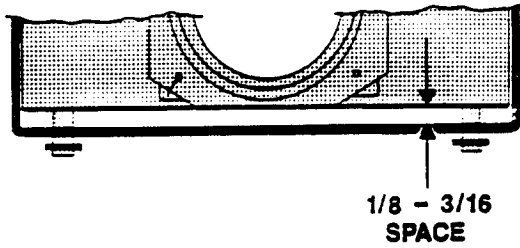

FIGURE 3.10

8. While holding the follower in the valley of the cam, install the outer section of the cable spool over the inner section. Release the follower and spool and check that the clearance set above is maintained. If so, make a new reference mark across the spool and remove the outer section of the spool and rotate it counter-clockwise one tooth-skip to Step 10.

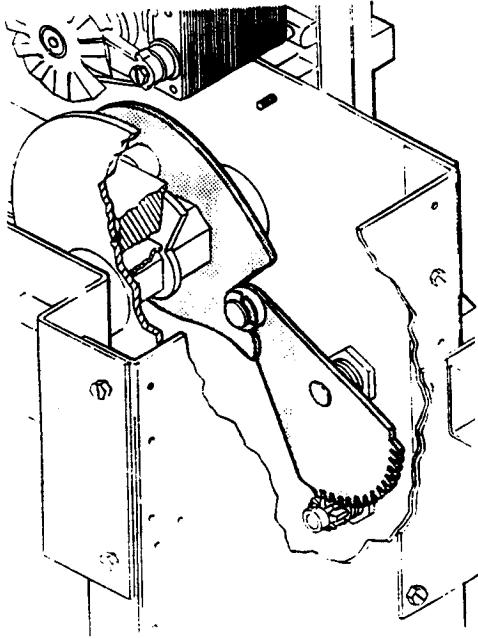

FIGURE 3.11

9. Carefully pull the outer section of the cable spool off and rotate it one tooth clockwise to tighten the cable and replace the outer spool.
10. Restore power and cycle the brewer again, watching for the three conditions above.
11. If the carriage is still not being drawn back far enough during the cycle, repeat Step 9.
12. After ensuring that the cable is adjusted correctly, replace the screw and washer that secure the two halves

of the cable spool and cycle the brewer to the brewing position and turn off the power. Swing the brewer closed and ensure that the latch pin drops into place. Restore power and test vend.

WATER SYSTEM

The water system is a gravity system (thus requiring no pumps or compressors) with an open air break at the tank inlet required by most local codes. The temperature control will maintain the water temperature near the boiling point. Coffee extraction requires hot water as close to boiling as possible. The thermostatic control system has been time proven as a very dependable, yet simple control method.

THE WATER TANK

The water tank is constructed of stainless steel with a welded internal baffle and holds approximately five gallons of water.

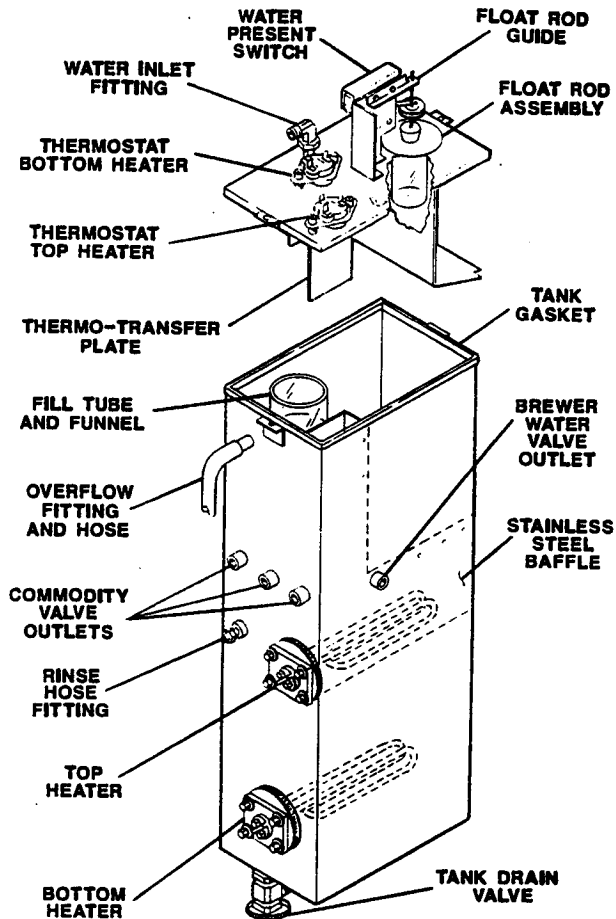

FIGURE 3.12

It has a removable lid that is sealed at the top of the tank with a gasket. The tank has two 1500 Watt heaters that are on a priority system, controlled by the thermostats mounted on the tank lid. The stainless steel baffle in the tank surrounding the top heater and brew water outlet fitting provides the hottest water in the tank at the brewer water valve outlet. This ensures continuous hot water for brewing coffee.

WATER INTAKE SYSTEM

There are two possible configurations in the intake system. The standard method is a straight tube with a shut-off valve between the inlet fitting and the water inlet valve. The optional method provides for a water filter to be installed as a part of the original equipment. The filter housing includes the shut-off valve.

The water inlet valve provides a sure method for controlling the intake of water into the water tank. This valve also functions as a safety overflow valve. If the safety overflow switch for the liquid waste or used grounds bucket is open, the valve will not allow water into the water tank. Also, if the water inlet valve remains on for more than 90 seconds, it is disabled.

THERMOSTATIC CONTROL SYSTEM

The thermostatic control system consist of two identically rated thermodiscs located on the lid of the tank. The top heater is controlled by the thermostat mounted on the left front corner of the tank lid, and has priority over the bottom heater and thermostat. The front thermostat senses the temperature of the water via a sensor that extends down inside the baffle of the tank. The bottom heater thermostat is mounted in the center of the tank lid. When the top heater thermostat is satisfied it will allow the bottom heater to come on and finish heating the entire tank. Except in cases of a heavy draw the bottom heater will maintain the correct temperature in the tank.

WATER LEVEL SWITCH

The water level switch (float switch) performs three functions. The switch is connected directly to the logic board at P10-1 and 3. Its primary function is to monitor the level of water in the tank and replenish the tank as needed during normal operation. The switch's other functions are helping the logic board monitor the condition of the inlet water system and the operation of the heaters. If the logic board senses that the water level switch is open for 90 seconds it disables the water inlet valve and turns off the heaters. Also, the logic board will not allow the heaters to turn on upon power being applied to the merchandiser until the float switch has been satisfied once. Therefore it is important NOT to lift the float switch while the tank is filling-this will cause the heaters to turn on before the tank is full.

ELECTRONIC LIQUID LEVEL CONTROL

Effective with S/N 39402, the float switch was replaced with an Electronic Liquid Level Control (ELLC). The function of the probe and associated circuit is the same as the float and switch. See the section "Version 2 Software Changes" on page 3.20 for additional information.

WATER DELIVERY SYSTEM

A maximum of five valves compromise the water delivery system. They are: the Coffee Brew Water Valve, the Chocolate Water Valve, the FD Coffee/Tea Water Valve, the Fresh Brew Tea Water Valve, and the Soup Water Valve. Each of these valves will release water into its particular segment of the commodity mixing channels, depending on the beverage selected. One valve is located allowing for the addition of a manifold and additional valve to be installed in the case of fresh brewed tea.

THE COFFEE BREW WATER VALVE

This valve is mounted on the face of the water tank directly behind the brewer. The valve outlet in the tank is contained within the stainless steel tank baffle along with the top heater. This allows the hottest water in the tank to be released through this valve and into the brewer. This valve is controlled by channel 9.

TEA, SOUP, FRESH BREW TEA AND CHOCOLATE VALVES

These valves are mounted on the left side of the water tank. Separate valves are essential because each beverage may require a different amount of water to brew the beverage properly, and each beverage is made and released from the machine through its own channels to avoid taste contamination. Each valve is controlled by at least one separate time channel on the logic board. Each of these valves is connected to the commodity rack by a flexible tube. The chocolate valve is positioned such that it can be removed and added to a manifold when a fourth valve is required for fresh brewed tea. Additional wires are included in the harness for use with a fresh tea brewer.

RINSE HOSE

A convenience feature is the rinse hose. This is provided for maintaining proper machine sanitation. It is long enough to reach each part of the machine which will normally require cleaning. To avoid any possibility of this hose leaking, a storage bracket has been provided, which holds the outlet of the hose above the normal water level in the tank.

OVERFLOW HOSE

Mounted in the upper left rear of the water tank is the overflow fitting. Should the water level in the tank rise too high, regardless of the reason, the excess will run out of the fitting, through the overflow tubing and directly to the liquid waste bucket. There should be no kinks or low spots in this hose.

OVERFLOW SAFETY

If the overflow condition continues the level in the waste pail will rise and eventually raise the float of the safety overflow switch shutting the water inlet valves and placing the machine on a "OUT OF ORDER" status. When "OUT OF ORDER", any coins inserted will be returned. All 110 volt functions from the motor control board will also be disabled.

OVERTEMPERATURE SAFETY THERMOSTAT

A manually resettable overtemperature safety thermostat is inserted in the overflow hose above the canister rack. This safety thermostat senses any boiling condition that exceeds approximately 4 minutes and disables the heater circuit by opening the neutral side of the line.

The thermostat is reset by pressing the small button in the center with a pencil eraser or similar non conductive object.

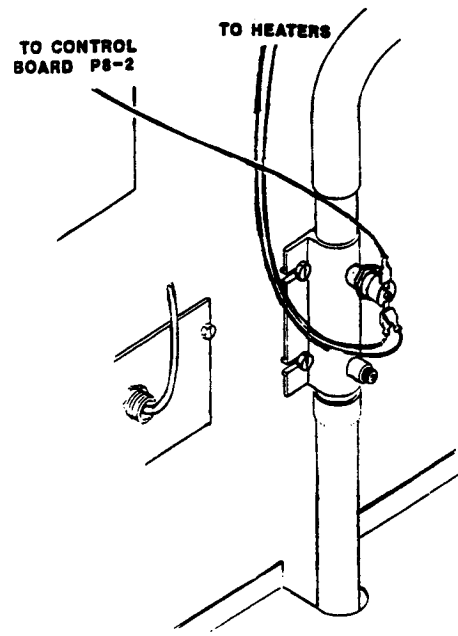

FIGURE 3.13

THE CANISTER RACK

The support for the entire dry product commodity system is of open construction design, with a minimum of horizontal surfaces to catch dust and spillage. The motors which drive the canister augers are all located behind and under the steel cover. Each motor may be removed, if necessary, by loosening four screws and lifting it out. Water tubes, to direct the water to the mixing channel and whipper are stainless steel and permanently attached to assure proper alignment.

COMMODITY SYSTEM

Containers for the dry product which the hot beverages machine dispenses are made of rugged translucent plastic. They are designed to dispense products on a first in-first out basis in order to insure a fresh product at all times.

The augering system used to dispense the products runs in reinforced nylon bearings to assure long trouble-free life. The dispensing end of the canister may have a louvered spout. These louvers control the accuracy of discharge so that the proper mixing is assured for each drink. The translucent materials permit the service person to estimate the contents of the canister without having to open the canister. Commodity levels may be marked on the outside of the canister so that the service person can easily refill them to a pre-determined level. This type of control will reduce product waste and assure commodity freshness by the elimination of overfilling.

THE HUMIDITY BAR

The humidity bar is a vital part of the commodity system. It is electrically heated and by providing a slightly higher temperature at the canister outlet ports will prevent moisture from being absorbed by the dry products, in areas where high humidity is present. If the machine is operated in a humid atmosphere without the humidity bar in operation, it is likely that the dry products will cake and not dispense properly. The tabs on the humidity bar fit into their respective slots in the commodity rack between the canisters. The humidity bar plugs into a harness on the left side of the cabinet.

THE STEAM EXHAUST CONTROL SYSTEM

Steam from the hot water needed to make the beverages is controlled by this system. Uncontrolled steam in a vending machine will create severe problems through caking and hardening of the dry products. Such a condition will prevent proper dispensing. By moving low velocity air, in high volume through the areas where steam is generated, the steam is removed before it can reach the dry product dispensers. The air is moved by a squirrel cage blower, and discharges outside the machine cabinet. The steam is generated whenever the machine is activated to dispense a beverage.

The hot water used to make coffee, tea or soup, passes through the main mixing channel as the dry products are dropped. Immediately adjacent to the mixing channel is a vacuum duct which is connected to the blower by a reinforced plastic duct. Directly over the mixing channel is the steam deflector and commodity chute. Lightener, sugar, tea and soup products are dropped into the moving liquid in the mixing channel directly from their respective canisters. The design of this deflector is such that a constant stream of dry air is pulled down through the commodity chutes of the deflector and actually helps delivery of the product to the mixing channel. At the same time this deflector effectively prevents the steam vapor from rising in the area of the commodity canister outlets.

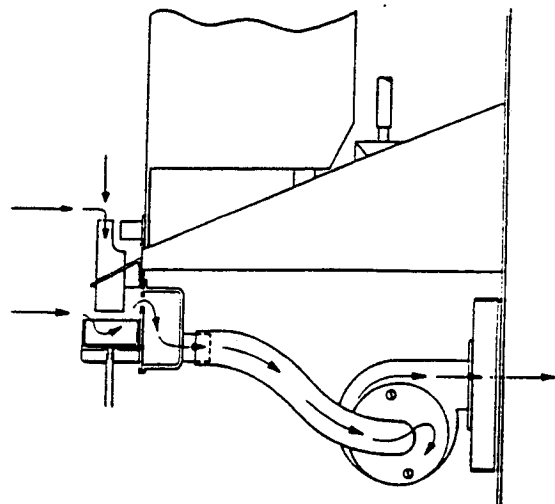

STEAM EXHAUST FLOW

FIGURE 3.14

STEAM EXHAUST FLOW

The components of the steam exhaust system: the mixing channel, the steam deflector, the steam duct, the hose to the blower, and the metal screen behind the exhaust fan assembly are all easily removed for cleaning. Cleaning is easily accomplished by rinsing in hot water. The mixing channel itself, which carries the beverage, should be sanitized according to the current industry practices.

CHOCOLATE WHIPPER

The chocolate beverage is thoroughly mixed and made more attractive to the user by whipping it as it is delivered. There is a separate mixing system for chocolate. It does not pass through the same mixing system as coffee or other beverages. As soon as the water for chocolate is released the whipper motor, which runs at high speed, starts. The chocolate powder is dropped from its canister directly into the water in the mixing bowl and flows into the whipper chamber

and then to the cup. The whipper parts are all of a food service approved plastic material, highly resistant to mechanical damage. They are easily removed, without tools, for sanitization. The assembly is held together by spring clips.

REMOVAL OF STEAM EXHAUST DUCT

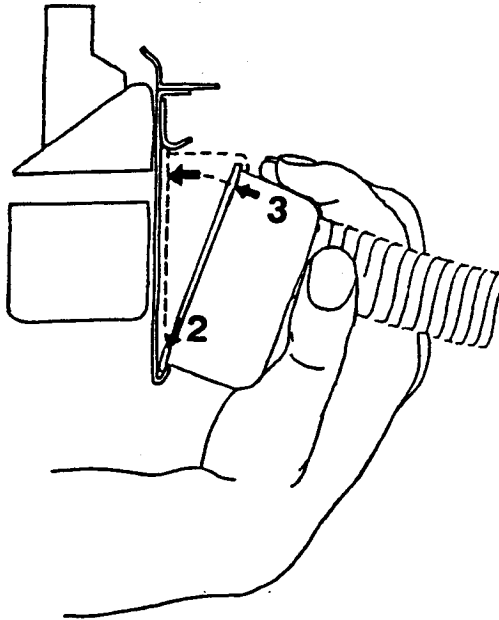

FIGURE 3.15

1. To remove the steam exhaust duct, pull the top down away from the front plate of the canister rack and lift from the bottom flange.
2. To install the steam exhaust duct, place the bottom lip of the duct on the bottom flange of the canister rack, behind the front plate.
3. Rotate the top of the exhaust duct toward the back of the front plate of the rack until it snaps securely in place.
4. Looking at the front of the rack, slide the duct left or right until the slots in the front plate properly line up with the ends of the exhaust duct.

MIXING CHANNEL AND ACCESSORIES

The use of specialty products may require the use of higher speed motors and/or additional whippers. Kits exist for the installation of additional whippers under the outlet of the soup mixing bowl and the channel mixing bowl. The adaptor harness for connecting to these additional whippers is included in the kits that add the whipper to the merchandiser.

- ◆ All canister racks are built the same regardless of the number of selections. Because of this standardization,

the soluble decaf is always wired to correspond to the third selection on the selector panel. If it is desired, in machines without fresh brewed decaf, the soluble decaf can be moved to the second selection by removing the white wire (marked "FDG") from the sanka motor and replacing it with the white wire marked "FDD". The soluble decaf will now be available in selection #2 and is controlled by channel 21.

FRESH TEA BREWER

The AP 203 also has the capability to deliver a cup of fresh brewed tea. Currently, this capability requires adding a manifold and a valve because the tea brewer requires a separate water valve. The tea brewer assembly consists of three basic parts: the canister and auger motor assembly, the tea brewer and the spent tea chute and drip tray. The entire assembly occupies the extreme right position on the canister rack. The canister and motor assembly are secured to the top of the rear shelf of the canister rack by one fixed clamp that allows for easy removal. The brewer and drip tray snap into the canister rack using the same locating tabs as a normal canister. The spent tea chute clips into the front of the brewer and guides the spent leaves to a second bucket for disposal. All wiring for the tea brewer is already included in the merchandiser and consists of a 6 pin plug which is placed in a square hole in the rear face of the canister rack and the two wires for the canister motor are fed up through the top shelf of the canister rack.

The tea brewer has a simple gravity fed, open brew chamber, similar in operation to the coffee brewer, except that no piston is used. A fresh brewed tea selection, once selected, begins with the canister motor augering a small quantity of leaf tea (approximately 3 grams for an 8 1/4 oz. drink) into the open brew chamber. The separate brewed tea water valve then opens and delivers the water to the brew chamber via a tube mounted on the side of the canister motor mounting bracket. Best results are achieved by reducing the flow of the water by adjusting the metering screw on the valve to stretch the water flow out over the longest time possible. This allows the water and tea to steep for as long as possible before the brewed tea liquid flows out the delivery spout and into the mixing channel where lightener and sugar can be added. The lightener and sugar are controlled by separate channels. The tea leaves are prevented from following the liquid by a fine mesh filter that also acts as the bottom of the brew chamber. After the liquid has seeped through the tea, the brewer cycle switch receives a start pulse from the motor control board and starts the brewer motor and its crank arm into the dump cycle. The crank arm moves the brew chamber and carriage forward as two ears on the side of the brew chamber contact two pawls that force the brew chamber up. As the ears of the brew chamber clear the support of the pawls, the four brew chamber springs snap the brew chamber down, ejecting the spent tea into the chute which guides it to the waste bucket. The brewer then cycles home to await the next vend.

CUP DELIVERY SYSTEM

Every beverage sold through the AP 203 hot beverage merchandiser requires a clean disposable cup. Inside the machine is a storage area for a large number of cups and a device to separate and dispense a single cup for each cycle of the machine. Included in the cup system is a cup present switch which will signal the logic board that no cups are available to dispense. The logic board will change the scrolling display to an "OUT OF ORDER M01" message after trying to move the cups to the dispensing mechanism for 30 seconds.

CUP CABINET

Cups are stored in an inline flat magazine mounted on the inside of the vendor door. This magazine is completely covered to protect the cups from accidental contamination. The entire cup cabinet may be swung out for easy access to the logic board, LED board and selection labels. The base of the cup cabinet holds the cup dispenser.

Cups are moved from the storage position to the dispensing mechanism (referred to as the "cup drop") as needed. When the stack of cups in the cup drop has been reduced to four or five cups the cup present switch is released which signals the logic board to energize the cup spiral motor.

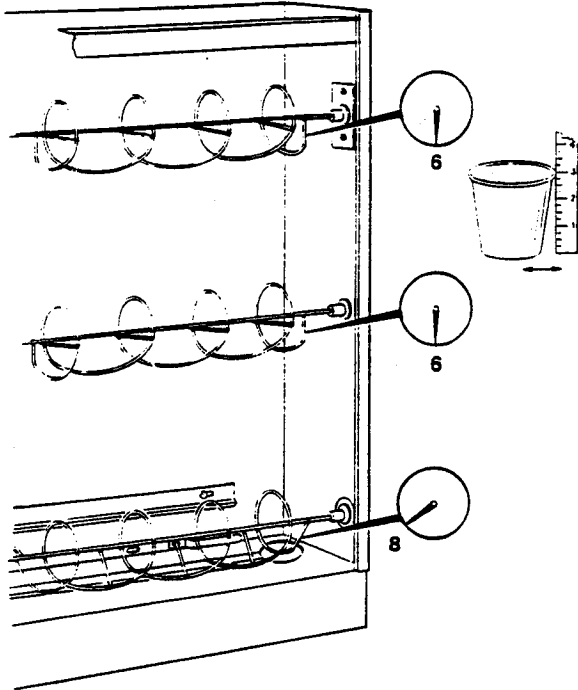

FIGURE 3.16

AUTOMATIC PRODUCTS 203 V5.0

The cup spirals will turn simultaneously to advance the remaining stacks of cups on the base plate toward the cup drop opening.

When the stack of cups nearest the cup drop opening is advanced, it will drop into the remaining cups. The new cups will depress the cup present switch which signals the logic board to deactivate the cup spiral motor. The cup spirals are designed so that a stack of standard vending cup will nestle between the turns. It is important that the spirals are properly oriented to each other so the stacks of cups will advance in a vertical position.

The drawing illustrates the relationship between the three spirals. When the spirals are correctly adjusted, the return wire at the end of the spirals will point as shown. When the upper two (which should be identical) spirals point to 6 o'clock, the bottom spiral should point to 8 o'clock. This is done because the lower part of a cup is smaller in diameter than the top rim.

The spirals are properly set before the machine leaves the factory and should not require adjustment before being put in service. The synchronized movement of the three spirals is maintained by the toothed drive belts which connect the toothed gear on the end of each spiral rod and the cup spiral motor.

CUP DROP MECHANISM

The cup separator used in the AP 203 hot drink merchandiser is a Lisem separator. The rotary motion of the cup drop motor is converted to a push-pull motion by a crank arm which drives the lever of the cup drop ring. The cup to be dropped is separated from the rest of the cups in the stack by the cams of the cup ring. The cup is then guided to the cupwell by a delivery chute. As the cams return to the starting position the next cup in the stack is prepared to be dropped for the next cycle. When the cup mechanism is in a standby position the lever of the cup ring is pulled back against the arm of the cup motor cycle switch.

This is the correct stopping position. If an adjustment of the switch is necessary, loosen slightly the two mounting screws and reposition the switch until the correct stop position is achieved and retighten the screws. However, the arm of the switch should not be bottomed against the body of the switch nor against the body of the cup ring.

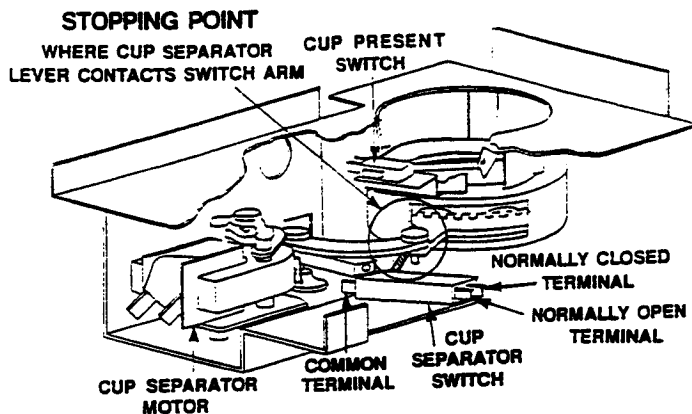

FIGURE 3.17

Starting voltage for the cup drop motor goes to the normally open (NO) contact of the cycle switch which is being held closed by the lever of the cup drop ring. This starting voltage is controlled by channel 3. The running voltage for the cup drop motor is connected to the normally closed (NC) contact of the switch. The common of the switch is connected to the cup drop motor.

The running voltage remains on the NC contact of the switch for the duration of the vend. If the cup drop lever fails to interrupt the voltage due to incorrect switch adjustment or a faulty switch the cup drop motor will run for the entire vend cycle.

If the start voltage remains on the NO contact of the switch longer than one complete revolution of the crank arm, the motor will run a second time. The length of the start voltage is controlled by the duration of channel 3.

USE YOUR OWN CUP OPTION

A new option available in the AP 203 detects the presence of a cup or mug in the cupwell and disables the cup delivery circuit. This option consists of three components, a printed circuit board with harness, a sensor assembly, and a cupwell with two holes to allow the sensors to detect the presence of a cup. The two infrared sensors generate a light beam across the cupwell through two holes in the side of the cupwell. If this beam is broken, the circuit board disables the cup drop start pulse. If the beam is blocked by the cupwell not being replaced correctly after service, or the sensors become covered for any reason, or the sensors and/or the circuit board fails to operate correctly, then the machine will not dispense a cup. If it becomes necessary to disable the USE YOUR OWN CUP option, the recommended procedure is:

1. Turn power off.

2. Remove blue (neutral) wire from cup drop motor.
3. Remove the single blue wire from the male spade with the double blue wires and connect the single blue wire to the empty cup drop motor terminal where the wire was removed in step 2.

This should restore the cup drop function to normal operation with a cup being dropped for every vend.

- ◆ If for any reason, the control board assembly is removed from the machine, then the Jumper Plug (P/N 35228) must be plugged onto the interconnect harness to allow the machine to operate in a normal manner (a cup is delivered every vend).

CHANGING TO A 9 OZ CUP

CHECK PAGES 6.01 AND 6.02 OF THE 203 PARTS MANUAL TO DETERMINE WHICH STYLE CUP DISPENSER YOU HAVE. FOR THE DISPENSER SHOWN ON 6.01 FOLLOW DIRECTIONS FOR 'OLD STYLE'. FOR THE DISPENSER SHOWN ON 6.02 FOLLOW DIRECTIONS FOR 'NEW STYLE'.

OLD STYLE

1. Remove the cover of the cup dispenser by lifting the cover up so the hinge pins are free of their sockets.
2. Remove all cups.
3. Remove the nuts from the right and left end of the upper support, and remove the upper support.
4. Loosen the two nuts securing the belt guard to the right side of the cup cabinet and remove the belt guard.
5. Remove the screws from the bearing plates on the top and middle spiral. Remove the drive belts between the spirals.
6. Remove the right end of the middle shaft from the nylon bearing and move the nylon to the outer hole nearest the front of the cup cabinet. Place the spiral shaft end back into the nylon.
7. Turn the three bearing plates 180 degrees so the spirals are in front of the screw holes in the bearing plates. It may be necessary to gently spread the top of the cup cabinet to gain clearance to rotate the bearing plates for the top spiral. Reinstall the mounting screws in the bearing plate, leaving the plates loose enough to be adjusted.
8. Place the cup to be used in the bottom spiral and against the cup guide on the back of the cup cabinet. Loosen the two nuts on the motor end of the bottom spiral plate and the two screws on the opposite end. Move the spiral in or out to obtain 1/4 inch clearance between the cup and the center shaft of the bottom spiral. Tighten the nuts and screws and adjust the position of the motor to tighten the small belt.
9. Replace and tighten the upper support.

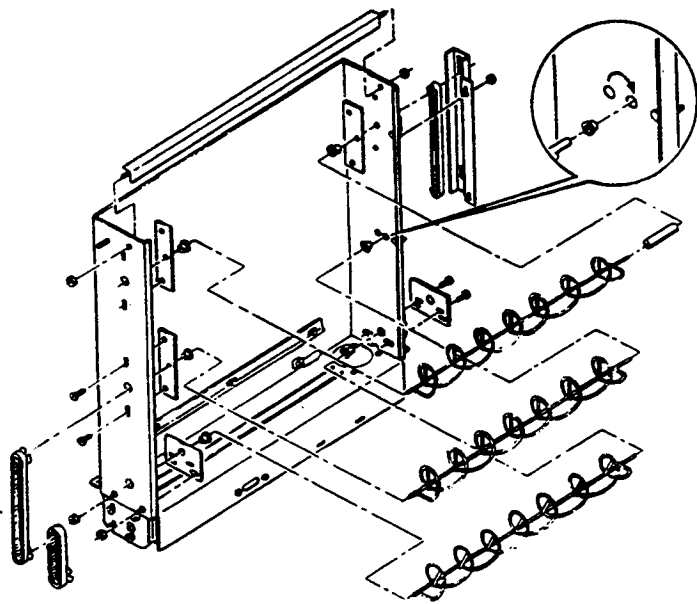

FIGURE 3.18

10. Replace the drive belts. Do not tighten!
11. Turn the bottom spiral until the right hand end points to 8 o'clock as previously described.
12. Position the center spiral so the right hand end points to 6 o'clock.
13. Tighten the belt between the bottom and center spiral by lifting up on the center spiral shaft and tightening the mounting screws. Be sure the teeth of the belt and the drive gear are meshed correctly. Maintain the 6 and 8 o'clock relationship between the two spirals while tightening the mounting screws.
14. Position the top spiral so the right hand end points to 6 o'clock. Repeat the belt tightening procedure following the same precautions as above. Replace and secure the belt guard.
15. When changing from a 7 or 8 1/4 oz. cup to a 9 oz. cup either the cup separator itself or the worm gears inside the cup separator must be changed. Both the cup separator and the worm gears are available from the RMI Spare Parts Dept.

NEW STYLE

1. Remove the cover of the cup dispenser by lifting the cover up so the hinge pins are free of their sockets.
2. Remove all cups.
3. Remove the nuts from the right and left end of the upper support, and remove the upper support.
4. Loosen the two nuts securing the belt guard to the right side of the cup cabinet and remove the belt guard.
5. Remove the screws from the bearing plates on the top and middle spiral. Remove the drive belts between the spirals.
6. Remove the right end of the middle shaft from the nyliner bearing and move the nyliner to the outer hole nearest the front of the cup cabinet. Place the spiral shaft end back into the nyliner.

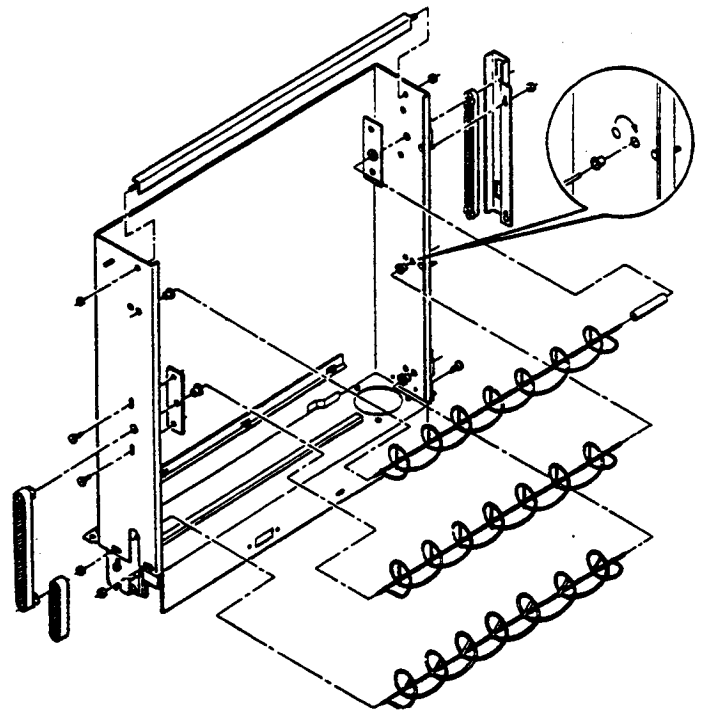

FIGURE 3.19

7. Remove the left end of the top shaft from the nyliner bearing and move the nyliner to the outer hole nearest the front of the cup cabinet. Place the spiral shaft end back into the nyliner.
8. Turn the two bearing plates 180 degrees so the spirals are in front of the screw holes in the bearing plates. It may be necessary to gently spread the top of the cup cabinet to gain clearance to rotate the bearing plates for the spirals. Reinstall the mounting screws in the bearing plate, leaving the plates loose enough to be adjusted.
9. Place the cup to be used in the bottom spiral and against the cup guide on the back of the cup cabinet.

Check for 1/4 inch clearance between the cup and the center shaft of the bottom spiral. If clearance is ok then proceed to the next step. If clearance is not correct then remove the two nuts on the motor end of the bottom spiral plate and the two screws on the opposite end. Gently spread the sides of the cup cabinet to gain clearance to remove the right end of the bottom shaft from the nyliner bearing and move the nyliner to the outer hole nearest the front of the cup cabinet. Place the spiral shaft end back into the nyliner. Replace and tighten the nuts and screws and adjust the position of the motor to tighten the small belt.

10. Replace and tighten the upper support.
11. Replace the drive belts. Do not tighten!
12. Turn the bottom spiral until the right hand end points to 8 o'clock as previously described.
13. Position the center spiral so the right hand end points to 6 o'clock.
14. Tighten the belt between the bottom and center spiral by lifting up on the center spiral shaft and tightening the mounting screws. Be sure the teeth of the belt and the drive gear are meshed correctly. Maintain the 6 and 8 o'clock relationship between the two spirals while tightening the mounting screws.
15. Position the top spiral so the right hand end points to 6 o'clock. Repeat the belt tightening procedure following the same precautions as above. Replace and secure the belt guard.
16. When changing from a 7 or 8 1/4 oz. cup to a 9 oz. cup either the cup separator itself or the worm gears inside the cup separator must be changed. Both the cup separator and the worm gears are available from the RMI Spare Parts Dept.

LARGE GRINDER

The large grinder in a AP 203 Hot Drink Merchandiser is a high torque, heavy duty, 1/5 Hp electric motor capable of repeated operations of short duration. The beans are gravity fed from the bean hopper into the inlet throat of the grinder. The beans are then forced to the cutter heads by a solid screw type auger. The beans are then ground by two hardened steel cutter heads with meshing teeth. The inner cutter head is fixed to the motor frame and the outer cutter head is turned by the shaft of the grinder motor. The double flat sided shaft of the grinder motor is connected to the outer cutter head by a polycarbonate coupling with a corresponding slot.

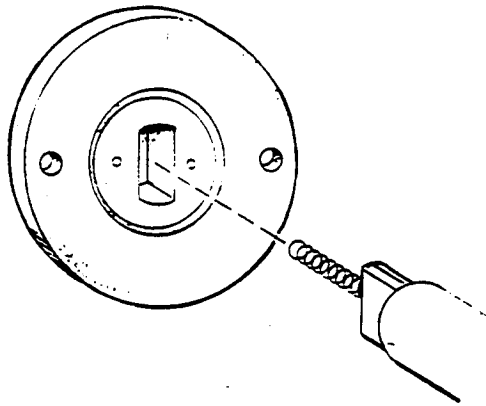

FIGURE 3.20

The coupling acts as a shock absorber and as protection for the grinder motor by shearing or rounding out if a foreign object becomes jammed between the cutter heads. Incorrect adjustment of the cutter heads or consistently grinding the coffee too fine can cause premature wear of the coupling. Correct adjustment of the cutter heads can be regained at any time by following the zero adjustment procedure on page 3.17. However, if an inconsistent grind is observed (chunks of unground beans and powdery dust in the same vend), then the grinder head should be disassembled and inspected for wear or damage to the coupling.

PROCEDURE FOR INSPECTION OF GRINDER HEAD

1. Open grinder swing out bracket. Pull out plunger on interlock switch to maintain power to the grinder. Close the gate on the bean hopper to prevent beans from entering the grinder.
2. Empty the grinder of beans and ground coffee. Grinder should be empty of beans before disassembly. Two methods are available to empty the grinder:
Method A) Run as many regular brewed coffee vends as necessary to empty the grinder.
Method B) Access **MODE 8** and select channel 4 and press **START**. Continuously run the

grinder until it is empty of beans and press **START** again to stop the grinder. Hold a container under the delivery chute to catch the grounds. Remove the coffee delivery chute.

NOTE: If equipped with a small grinder or a LG canister they must be removed from the swing out bracket. The mini grinder should be emptied using similar methods as above. The correct channel for the small grinder is channel 7.

3. After the grinder is empty, remove the two silver thumbnuts that secure the grinder adjustment dial and casting to the frame of the motor.
4. Remove and inspect the thrust bearing from the recess in the end of the coupling.

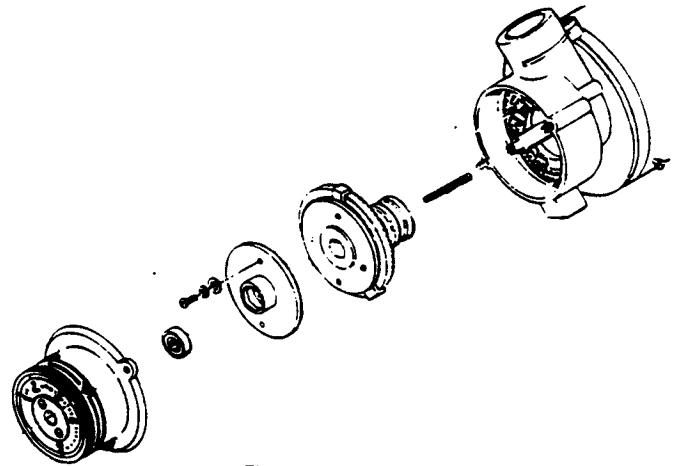

FIGURE 3.21

5. Remove outer cutter head assembly by pulling straight out on the cutter head and coupling.
6. Inspect the drive slot in the coupling by holding the cutter head assembly up to a light and sighting down the hole in the center of the auger.
7. If the edges of the slot are worn or rounded out, then it will be necessary to replace the coupling by removing the two screws that secure the coupling to the auger assembly.
8. Clean the grinder of any ground coffee or beans with a small stiff brush. Check for any evidence of a foreign object that could be present.
9. Assemble the grinder in reverse order, ensure that the spring is in the grinder shaft, the cutter head assembly is aligned correctly with the grinder shaft, and the bearing is replaced in the recess of the coupling.
10. Proceed to step 3 of the Static Zero Adjustment for the Large Grinder and complete the procedure from that point.

STATIC ZERO ADJUSTMENT FOR THE LARGE GRINDER

If, after a period of use, the brewed coffee becomes weaker or a variation in strength is detected and the grams of ground coffee, water temperature, etc. seems normal, it may be time to adjust the distance between the grinder plates. In order to maintain the consistency of the grind and the gram throw, a periodic zero adjustment may be needed for the best brewing results. Brewing efficiency can be regained by zero adjusting the grinder as outlined in the following steps.

1. Open grinder swing out bracket. Pull out plunger on interlock switch to maintain power to the grinder. Slide the gate on the bean hopper to prevent beans from entering the grinder.
2. Empty the grinder of beans and ground coffee. Grinder must be completely empty of beans before the zero adjustment can be made. Two methods are available to empty the grinder:
 - Method A) Run as many regular brewed coffee vends as necessary to empty the grinder.
 - Method B) Access **MODE 8** and select channel 4 and press **START**. Continuously run the grinder until it is empty of beans and press **START** again to stop the grinder.
 Hold a container under the delivery chute to catch the grounds. Remove the coffee delivery chute.

NOTE: If equipped with a small grinder or a LG canister, they must be removed from the swing out bracket. The mini grinder should be emptied using similar methods as above. The correct channel for the small grinder is channel 7.

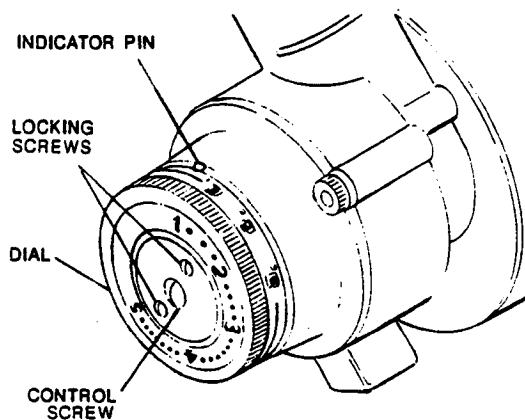
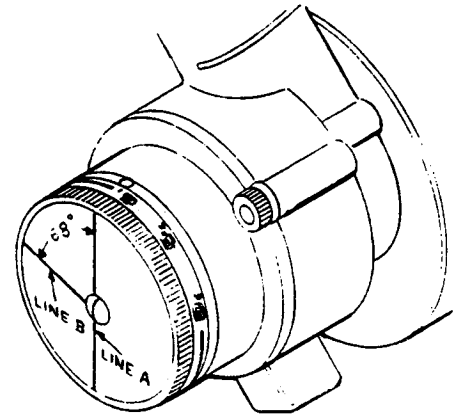

FIGURE 3.22

3. After the grinder is empty, turn the grind adjustment dial to the #1 position. The dial must be held in this position until the zero adjustment procedure is completed!

4. Loosen the two locking screws and turn the center control screw clockwise (facing the dial) until snug.
5. Place the adjustment gauge (See page 3.18 for gauge) on the dial with Line A aligned with the slot on the control head screw.



ADJUSTMENT GAUGE IN POSITION

FIGURE 3.23

6. While holding the dial in the #1 position and the gauge stationary on the dial, turn the control screw counter-clockwise until the screw slot is aligned with Line B on the gauge (68 degrees), remove the gauge and tighten the two locking screws.
7. Open the gate to allow beans back into the grinder. Replace the coffee delivery chute. Return the dial to your original setting (between 2 1/2 and 3) and run 3 or 4 fresh brew vends to refill the grinder. Check the gram throw by accessing **MODE 12**, channel 4. Reset if necessary.
8. Return the swing out bracket to the operate position and run three test vends of regular coffee. If the brew cycle seems normal with no strain on the motor and acceptable dry spent grounds, leave the adjustment dial in its current position. If necessary to adjust the grind setting, recheck the gram throw. Open swing out bracket and replace any items removed in step 2 above.

STATIC ZERO ADJUSTMENT FOR THE MINI-GRINDER

If, after a period of use, the brewed coffee becomes weaker or a variation in strength is detected and the grams of ground coffee, water temperature, etc. seems normal, it may be time to adjust the distance between the grinder plates. In order to maintain the consistency of the grind and the gram throw, a periodic zero adjustment may be needed for the best brewing results. Brewing efficiency can be regained by zero adjusting the grinder as outlined in the following steps.

1. Open grinder swing out bracket. Pull out plunger on interlock switch to maintain power to the mini-grinder. Slide the gate on the bean hopper to prevent beans from entering the mini-grinder.
2. Empty the mini-grinder of beans and ground coffee. Grinder must be completely empty of beans before the zero adjustment can be made. Two methods are available to empty the mini-grinder:

Method A) Run as many regular brewed coffee vends as necessary to empty the mini-grinder.

Method B) Access **MODE 8** and select channel 7 and press **START**. Continuously run the mini-grinder until it is empty of beans and press **START** again to stop the mini-grinder.

Hold a container under the delivery chute to catch the grounds. Remove the coffee delivery chute. Remove the mini-grinder from the swing out bracket.

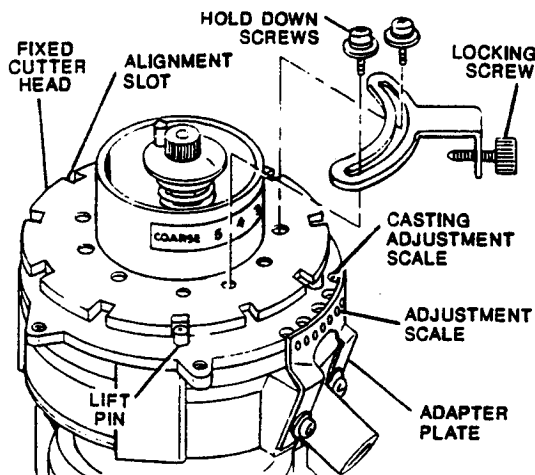

FIGURE 3.24

3. After the mini-grinder is empty, remove the locking device (pointer) and the locking screw from the top face of the fixed cutter head by removing the two screws and washers.

4. Turn the fixed cutter head of the mini-grinder counter-clockwise until hand tight.

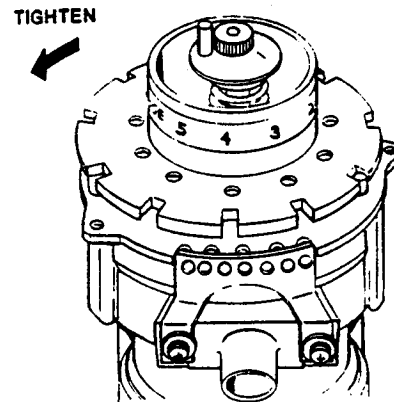

FIGURE 3.25

NOTE: This cutter head has a left hand thread.

5. Observe the relationship of the three spring-loaded lift pins and how they align with the ten slots on the outer edge of the fixed cutter head. If any of the three pins are aligned with any one of the 10 slots, you are ready for Step B. If none of the pins are aligned with any of the slots, slowly loosen the fixed cutter head clockwise until one pin is centered in any one of the ten slots on the outer edge of the fixed cutter head-proceed to Step B. **Step B** - Continue turning the fixed cutter head clockwise until another pin is centered in any one of the ten slots. Continue turning the fixed cutter head clockwise until another pin is centered in any one of the ten slots. This is the #1 grind position. This is the finest grind of coffee that should be ground.

seems normal with no strain on the motor and acceptable dry spent grounds, leave the locking device in its current position. If necessary to adjust the grind setting, recheck the gram throw.

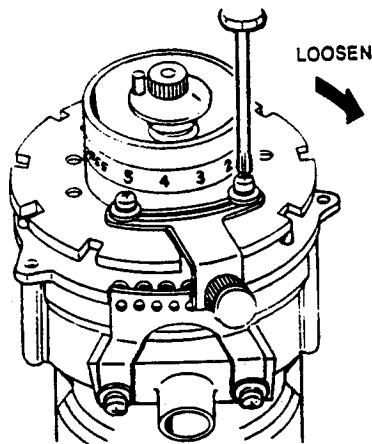

FIGURE 3.26

NOTE: Clicks can be heard at each position.

6. Reinstall the locking device removed in step 3 with the locking screw in the far right position in the adjusting scale. Tighten the two screws securing the locking device to the top of the fixed cutter head.

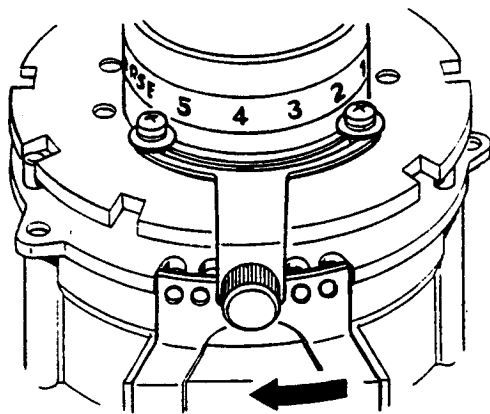
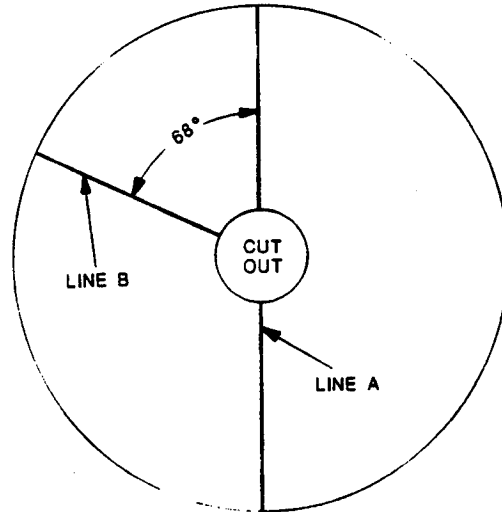

FIGURE 3.27

7. Move the locking screw to the center position on the adjustment scale. Using the adaptor plate with the 7 holes, then hole #4 will be the center position. Tighten the locking screw.
8. Reinstall the mini-grinder on the swing out bracket. Open the gate to allow beans back into the grinder. Replace the coffee delivery chute. Run 3 or 4 fresh brew decaf vends to refill the grinder. Check the gram throw by accessing **MODE 12**, channel 7. Reset if necessary.
9. Return the swing out bracket to the operate position and run three test vends of decaf coffee. If the brew cycle

ZERO ADJUSTMENT GAUGE FOR LARGE GRINDER



GAUGE CAN BE COPIED AND CUT OUT TO PERFORM ZERO ADJ. PROCEDURE.

FIGURE 3.28

TROUBLESHOOTING FOR AP 203 HOT DRINK MACHINE

If **START/ENTER** does not operate- check security key switch for correct position. Key should be able to be removed. If key cannot be removed, then security key switch is on and the **START/ENTER** switch is disabled.

If **MODE** switch does not operate, check P11, P13 and P16 on the logic control board to determine if the **MODE** switch is reversed with the **DISCOUNT** switch or the **CUP PRESENT** switch. The **MODE** switch should be connected to P16. The **CUP PRESENT** switch should be connected to P13

If scrolling display on door shows '**OUT OF ORDER**': Refer to Appendix III-**OUT OF ORDER CODES** and check the three obvious reasons for the **OUT OF ORDER** message:

- 1) Buckets are full - **CODE M20**
- 2) Water tank is not full - **CODE M02**
- 3) Machine is out of cups - **CODE M01**

If either the water inlet valve or the cup spiral motor have been on for 90 continuous seconds the **OUT OF ORDER** message will appear. Another cause for the **OUT OF ORDER** message could be a constant low voltage source (ie-below 104Vac) from the wall outlet supplying the machine.

During initial set-up two other situations may occur:

- 1) Until the front thermostat has cycled off once after initial power up, the machine will not allow a vend to occur to prevent delivery of a cold cup. This may be temporarily defeated by removing and reconnecting either wire from the front thermostat to simulate the thermostat being satisfied. This applies only to **LOGIC LEVEL THERMOSTATS**. See Appendix IV.
- 2) If a logic board was changed or the software was changed, it may be necessary to proceed to **MODE 16** and reload the standard times. Caution should be observed because activating **MODE 16** will cause any channel time or price information that was changed from the standards to be lost. Further information on **MODE 16** can be obtained in the description of modes.
- ◆ If a logic board or software chip has been replaced and the board or chip is configured as a cold drink, the large grinder will immediately start to run. Swing the grinder swingout bracket out to interrupt power to the grinder and check **MODE 11** for the correct configuration ("**H**" flashing). Change the configuration and reload the factory standard times and settings in **MODE 16**.

Using the black mode switch located on inside of the door, set the display to **MODE 6** and press **START** button and check the list of switches that will appear on the display for the following switches and their correct operating position.

This list of switches can be used to check each switch that functions as a sensor for the logic board. After running **MODE 6** test the first time and noting each switch number that appears, any switches' position can be physically changed to determine if the switch and its wiring to the logic board are correct. See Appendix I for membrane switch locations.

SWITCH #	INDICATION	WILL APPEAR IN NORMAL OPERATION
24 or below	faulty membrane (selector)	N
25	discount switch	Y/N
26	auto flush enable switch	Y/N
27	bucket switch activated	N
28	cups present	Y
33	brewer water switch	Y
34	brewer cycle switch	Y
35	brewer delay switch	N
36	front thermostat	Y/N
37	rear thermostat	Y/N
39	water inlet switch	Y
40	tank probe (ELLC)	N

(See Version 2 software
on next page)

EXAMPLE: Switch 39 (water present or float switch) will show in **MODE 6** normally. After disabling the water inlet valve and running water out of the tank via the rinse hose so the float drops and the switch arm drops, press **START** again to run another test. This time switch 39 should not appear. This proves that the switch, the wiring from the switch to the logic board, and the sensor circuit on the logic board are functioning correctly. A similar test for any of the other switches can be devised.

After determining that the switches function correctly and a problem can be traced to a specific channel or device, the following procedure should be used to locate the source of the problem.

Check **MODE 11** to confirm that the correct options are set for the machine (Y/N).

Visually inspect all connectors and terminals for any pins that have become loose or backed out of the connectors themselves. Also confirm that the numbers on the wires correspond to the correct pin numbers.

Check the timing chart for the specific channel involved.

Confirm the start and duration settings for the appropriate channel are correct by using the security key and accessing **MODE 12**. Check the times and run a channel test (after returning to **MODE 12**) by pressing the regular lightener selection. If the specific channel does not operate with the

MODE 12 test, proceed to MODE 8 and select the faulty channel and press the START button. Once START is pushed, the function or device will have power applied to it and the problem can be located by using a voltmeter starting at the correct connector pins on the motor control board. The connectors must remain on the board to provide a load. If no voltage appears between the pin (determined by referring to the wiring diagram) and neutral (blue wire) then the problem is probably located in the motor control board. If voltage is present at the pins on the motor control board, then the problem is located downstream of the motor control board (ie. between the motor control board and the device itself).

VERSION 2 SOFTWARE CHANGES

Effective the week of 4/15/91, S/N 39402, a number of changes to the 203 have been made. The primary change is a change to Version 2 software. Version 2 software chips can be identified by observing the chart number on the bottom line of the paper label. The first three digits should be 002. The following information details these changes.

Main EPROM on logic board changes to version 2 software. This version provides corrections for all known errors plus the replacement of the heater tank float with an Electronic Liquid Level Control. This requires that a separate harness is used to connect the probe for the ELLC to the logic board. All model 203 manufactured after 12/3/90 S/N 37785 with the new style harness have the wires included to connect the probe to the logic board. Older machines can be retrofitted with the additional harness to replace the float with a ELLC probe by using kit # 35335. Version 2 logic boards cannot replace a version 1 logic board unless the tank harness and software are changed. A new part number is used to identify the correct spare parts replacement logic board. P/N 31800-V2 indicates a version 2 logic board. Two labels will be placed in each machine to identify the presence of a version 2 logic board. One label will be located on the schematic on the cup wrapper door and the other will be placed on the logic board connection label located on the back of the LED panel.

The change to an Electronic Liquid Level Control (ELLC) causes the switch numbers that appear in MODE 6 to change. Switch 39, formerly the water level switch is no longer used and does not appear. Switch 40 now reflects the condition of the ELLC, and will only appear when the tank is calling for water. The probe is connected to P7 on the logic board.

Version 2 software also changes the use and the name of the strength delay. Testing has shown that moving the strength delay towards the beginning of the cycle and using it to delay the piston moving down allows more brew water to be added and less bypass water to be used. This also allows for longer water to coffee contact time for increased extraction and provides less back pressure in the cylinder by allowing a

degassing period. To do this, a change in the position of the third cam so the switch is in the valley of the cam at standby, and rides up on the high side of the switch during brew cycle, causes a change in the wiring of the delay switch and retiming channel 11 is necessary. These changes cause the brewer to pause while the piston is in the open (up) position. Because this change affects the assembly of the brewer, a new part number is used for a complete version 2 brewer. The fixed times listed in the table below are used in version 2 software to allow all the brew water to be added through the brewer. All brew water is controlled by channel 9.

CHANNEL PRESET FOR VERSION 2

CHANNEL	11	11	13
CUP SIZE	START	DUR	DUR
7oz.	7.4	1.00	0.00
8 ¹ / ₄ oz.	7.4	1.50	0.00
9oz.	7.4	2.00	0.00
12oz.	7.4	3.30	0.00

We have also changed the soup motor from 90 rpm to 180 rpm. This change allows placement of specialty coffees in soup position without changing the motor. Additional flexibility can be gained by exchanging the soup and sanko motors to place GFIC in sanko and retiming the appropriate channels.

VERSION 2 SOFTWARE WITH YELLOW LABEL

Effective in November 1991, the label on the software EEPROM will change to a yellow label to indicate a small change. This change reassigns channel 19 from "Water - espresso coffee FD" to "Water - FD tea" to allow for more flexibility when using a specialty coffee in the FD/gourmet position by splitting the channels that control the trough delivery valve. This change is compatible with all existing version 2 boards by entering the same duration from channel 18 to channel 19. See Appendix I, pg 2.11.

203 TROUBLESHOOTING CHART

PROBLEM	POSSIBLE CAUSE	REMEDY
Scrolling Display is Blank	Press any prime selection	YES-with any message proceed to MODE 17 to see if any user message is loaded
	Does any selection LED come on?	YES-with no message- check ribbon cable from LCB to scrolling display to confirm that the cable is connected correctly. Confirm that a language chip is installed.
		NO Proceed to troubleshooting section regarding no power to machine.
Scrolling display shows: OUT OF ORDER	Water tank not full CODE M02	Check inlet water valves. Power down-power up control circuit breaker to reset 90 second safety timer. Check for clogged water filter
		Check water supply for minimum incoming water pressure
	Buckets are full CODE M20	Check bucket switches for correct operation. Measure MCB P7-4&6 for -6.5Vdc. If 0Vdc is measured-bucket circuit is activated.
	No cups CODE M01	Check cups and cup present switch for correct adjustment. Power down-power up control circuit breaker to reset 30 second timer to allow spiral motor to run.
	Water not hot CODE M04 See Appendix IV	Front thermostat has not been satisfied since initial power up-disconnect and reconnect one wire from front thermostat to simulate the thermostat being satisfied.
	Low supply voltage (115Vac) CODE M20	Check wall outlet for 115Vac \pm 10%
	Software or logic board has been replaced-CODE M10	Check configuration in MODE 11 and reload MODE 16. Return to MODE 11 and recheck configuration and options

PROBLEM	POSSIBLE CAUSE	REMEDY
Scrolling display shows: PLEASE WAIT	Water is not hot enough See Appendix IV	Front thermostat has not been satisfied since initial power up-disconnect and reconnect one wire from front thermostat to simulate the thermostat being satisfied.
No power-complete machine including fluorescent light and service outlet	Power cord unplugged Loose or broken wire in power cord Bad connections in power cord to EMI filter and switch panel No voltage from wall outlet On/off switch or wiring defective or open	Plug in power cord Repair or replace Check all terminals Check outlet and supply circuit breaker Repair or replace
Machine will not vend or accept money	Circuit breaker(s) tripped Power transformer disconnected or defective Defective coin mechanism	Reset or replace Repair or replace Check MCB P1-3 and P1-5 for 24Vac Replace or disconnect and test machine using MODE 2
Start/Enter does not operate	MODE 13-MS1600 option is Y Security key switch is on	Change to N Key cannot be removed-return to off so key can be removed
Bottom heater comes on first during initial power up	110Vac hot reversed at MCB	Check MCB P8-1&3 reversed P8-1 top heater P8-3 bottom heater
Excessive amount of liquid in overflow bucket	Water present (float) switch defective or out of adjustment Float waterlogged Commodity water valve leaking Water inlet valve leaking Flush cycle activating every 12 hours	Adjust or replace switch Replace float Repair or replace Repair or replace-check supply line for high pressure. Install pressure regulator to correct. Disable or reduce flush cycle or service machine more frequently

PROBLEM	POSSIBLE CAUSE	REMEDY
Lightener and/or sugar not selected but appearing in drink	Clogged exhaust system	Check steam exhaust (duct,hose,fan and humidity bar)-clean as needed
	Exhaust motor not running	Service or replace
	Scratched or defective trough causing poor wash	Replace
Wet grounds dispensed from brewer	Mixed products in canisters	Dump products and replace
	Clogged brew filter	Replace
	Clogged filter support screen	Clean or replace
	Scored or cracked brew cylinder	Replace
	Worn or defective piston or seal	Replace
	Incorrect grind of coffee	Check grinder setting and refer to zero adjustment procedure
	Check gram throw	Using gram scale, adjust correct channels
Large grinder operates, small grinder or decaf auger does not	Soft water or coffee gases causing excessive pressure in brewer	Refer to Brewer section in manual
	Neutral for swing out bracket reversed	Check P10 and P11 on MCB 115Vac hot on P10-1 and P11-1 115Vac neutral on P10-2 and P11-2.
	Check configuration MODE 11-Option 2	Option 2 should be Y

CONFIGURATION AND OPTIONS

Regular coffee brewer does not operate	CHECK MODE 11 OPTIONS Check canister rack motors for correct electrical connections	Option 1 should read Y
FD regular coffee does not operate		Option 1 should read N
Decaf brewer does not operate		Option 2 should read Y
Decaf brewer does operate and shouldn't		Option 2 should read N
Soup does not operate		Option 3 should read N
FD tea does not operate		Option 4 should read N
Weak and/or cold coffee and overfilling cup	Improper gram throw or grind	Check gram throw and grinder setting
	Brew water valve leaking	Repair or replace valve

PROBLEM	POSSIBLE CAUSE	REMEDY
Weak and/or cold coffee and overfilling cup	Defective thermostat	Replace
	Defective heater	Replace
	Incorrect alignment of brew chamber and filter	Adjust stop position of brewer-check brewer motor brake arm for coasting
Cup occasionally not full (Short cup)	Float rod sticking or bent	Straighten or replace
	Water inlet switch sticking or defective	Replace
	Float rod access cover loose	Secure in proper position
	Water valves opening late due to mechanical defect or low voltage	Repair or replace valve
	Brewer cable not adjusted properly causing brewer leak	Adjust cable
	Brewer stop position incorrect trapping grounds on seal	Adjust front brewer cam for correct stop position
	Check brew chamber seal for excessive grounds	Check for proper alignment of coffee delivery chute
	Clogged water filter	Replace
	Low water supply or damaged supply line	Change water supply or replace water supply line
	Incorrect cylinder and carriage alignment	Check brewer cable adjustment
Grounds in cup	Brewer dumping wet grounds	See wet grounds section
	Torn or ripped brew filter	Replace
	Missing funnel cover	Replace
Water only-No coffee	Carriage wiper binding on filter	Confirm that brew filter is seated correctly Clean brew base assembly
	Warped brew filter	Replace
	Bent filter support screen	Replace
	LG canister tunneling	Solenoid defective or disconnected Auger or agitator inoperative
	Bean hopper sliding gate closed	Open sliding gate

PROBLEM	POSSIBLE CAUSE	REMEDY
Water only-No coffee (continued)	Faulty interlock switch or assembly	Adjust or replace
	No coffee in canister	Service
	Check channels in MODE 12 for correct times	See timing chart
Water in grounds bucket	Brew water valve leaking	Repair or replace valve
	Defective piston seal (wet grounds)	Replace
	Incorrect cylinder and carriage alignment	Check brewer cable adjustment
Brewer leaking	Refer to brewer section in service manual	Soft water or coffee gases causing stalling or excessive pressure
	Excessive amount of coffee grounds on brew base assembly	Clean or service
	Cracked or damaged brew cylinder	Replace
	Special washers missing from between brew cylinder and cylinder rods	Replace
	Worn or damaged brew chamber seal	Replace
	Cracked or damaged brew chamber	Replace
	Worn filter or seal	Replace
	Cracked or damaged brew carriage	Replace
	Brew filter support bracket broken	Replace
	Improper brew cable adjustment	Adjust
	Funnel support brace bowed	Replace brew base frame
	Worn or broken delivery funnel	Replace
	Brew base assembly-parts worn or broken (springs, pawls,etc)	Replace parts
No cups	Cups jammed together in cup cabinet	Adjust or replace cup present switch
	Wrong type cups or cup ring	Replace cups or cup ring
	Defective cup drop motor	Replace
	USE YOUR OWN CUP option not working	Cupwell not aligned correctly Sensors blocked or dirty Sensors or board malfunctioning See Service Section, page 3.12

PROBLEM	POSSIBLE CAUSE	REMEDY	
Multiple or intermittent cups	Cup motor cycle switch out of adjustment, broken or defective	Adjust or replace	
	Cup motor brake arm sticking on causing motor to coast	Check for rubber tip on brake arm-repair or replace	
	Cup drop motor start pulse too long	Check MODE 12,channel 3 for correct duration	
	Cup motor cycle switch wiring reversed	Correct wiring	
Selection or additive not working	Security key switch on	Key cannot be removed-return to off so key can be removed	
	Canister empty	Service machine	
	Selection not activated	Check MODE 11 options	
	Canister rack motors not wired correctly	Correct wiring	
	Defective selection membrane or LED board	Does selection beep when pressed? Yes-replace LED board No-Replace selection membrane	
Machine vending with no money or returning money deposited and vending	Discount switch on with discount % set at 100%	Turn off discount switch	
	Discount switch does not turn off free vending	Check for correct wiring of cup present and discount switches- LCB P-11 is discount switch, P-13 is cup present switch	
	Free vend option set to YES	Check MODE 13, set free vend option to NO	
	Free count option set incorrectly	Check MODE 13, set free count option correctly	
	Selection price set to .00	Set price correctly-MODE 4	
Pressing mode switch, does not enter service mode	Check for correct wiring of mode switch at LCB	Check LCB P-16 is mode switch	
Pressing mode switch, cup spiral motor runs	Check for correct wiring of mode switch and cup present switch	Check LCB P-16 is mode switch P-13 is cup present switch	
Turning on discount switch enters a service mode	Check for correct wiring of discount switch and mode switch	Check LCB P-16 is mode switch, P-11 is discount switch	

DIRECTIONS FOR REPLACEMENT OF LOGIC CONTROL BOARD

**DO NOT REMOVE THE BOARD OR THE EPROM WITHOUT CARRYING OUT THIS PROCEDURE!
NOTE DOWN ALL AUDIT DATA AND MACHINE SETTINGS IF POSSIBLE. THE FACTORY
STANDARD SETTINGS AND PRICES WILL BE LOADED AS A RESULT OF THIS PROCEDURE.**

1. Open machine door.
2. Depress the mode switch until the display indicates 'MODE 01'.
3. Record all accountability information required by pressing the start switch and stepping through MODE 1.
4. Access MODE 4 and record all price setting information.
5. Insert security key into the service key switch, turn the switch to the "on" position and then back to the "off" position.
6. Depress the mode switch until the display indicates 'MODE 12'.
7. Depress the start switch. The display will indicate 'CH 00'
8. Select all channels that have been changed from the factory standards and record the START, DURATION and MODIFIER times. To select a channel use the next digit switch and increment digit switches to select the desired channel and press ENTER/START to read the times from the scrolling display. Use chart in Appendix I to record information.
9. Depress the mode switch until the display indicates 'MODE 13'. Press ENTER/START and progress through the mode and record any changes from the factory standards.
10. Remove power from the machine and replace board and/or software EPROM noting the correct arrangement of all connectors or the orientation of the EPROM.
11. Restore power to the machine. Insert security key into the service key switch, turn the switch to the "on" position and then back to the "off" position. This allows the key to be removed and prevent it being left in the machine in error.
12. The display should indicate 'MODE 11'.
13. Depress the start switch. The display will indicate 'CONFIG H/B/C'. The 'H' should be flashing to indicate that the machine is set up as a 203 hot drink machine
14. If the 'H' is not flashing press the change digit switch until it is. Then depress the START switch. The machine will then jump automatically to mode 16 to load the default values appropriate for the 203 machine. Go to step 16.
15. If the 'H' (203) was flashing correctly depress the mode switch until the display indicates 'MODE 16'.
16. Depress the START switch and the display will indicate 'MODE 16' again. Using the increment digit and next digit switches change the '16' to '27' and then depress the START switch. The display will go blank.
17. When initialization and loading of the default values is complete the display will scroll the user message again.
18. Return to mode 11, recheck configuration and set the machine options.
19. Access MODE 4 and set all selection prices.
20. Access MODE 12 and reset all channel times recorded in step 8 above. Proceed to MODE 13 and reset all payment options.

MOTOR CONTROL BOARD PIN CONNECTIONS

P1 LOGIC POWER SUPPLY

P1-1 110Vac to transformer primary
 P1-2 110Vac return
 P1-3 24Vac to motor control board
 P1-4 Key
 P1-5 24Vac return

P2 110Vac CONSTANT AND SWITCHED SUPPLY VOLTAGE

P2-0 Key (future)
 P2-1 110Vac to inlet water valves
 P2-2 Key
 P2-3 110Vac neutral
 P2-4 110Vac constant supply
 P2-5 110Vac switched by bucket switches-disables all relay outputs-SWITCH #27
 P2-6 Key (future)

P3 CUP DROP AND SPIRAL CONTROL

P3-1 Cup drop start pulse 110Vac controlled by channel 3
 P3-2 Cup spiral advance 110Vac-disables machine 'Out of Order' 90 seconds after cup switch is on continuously
 P3-4 Key
 P3-5 110Vac neutral - if no wire is present, neutral is provided through P2-3

P4 BREWER AND SWING OUT BRACKET

P4-1 Brewer motor 110Vac-controlled by channel 8
 P4-2 Key
 P4-3 Brew water valve 110Vac-controlled by channel 9
 P4-4 Neutral 110Vac brewer and brew water valve
 P4-5 Regular coffee auger 110Vac (through swing out interlock) controlled by channel 6
 P4-6 Decaf auger motor 110Vac (through swing out interlock) controlled by channel 7

P5 COMMODITY VALVES-ALL 110Vac

P5-2 Commodity trough valve-controlled by channel 13,18,19
 P5-3 Brewed tea valve-controlled by channel 26
 P5-4 Chocolate valve-controlled by channel 33
 P5-5 Soup valve-controlled by channel 35
 P5-6 Key
 P5-7 Neutral

P6 CANNISTER RACK-ALL 110Vac MOTORS

		CONTROLLED BY
		CHANNEL #
P6-6	Sugar substitute	16,25,33,68
P6-7	FD gourmet	22
P6-8	FD coffee	20
P6-9	FD decaf	21
P6-10	Soup	36
P6-11	Tea FD or FB	27
P6-12	Lightener	14,23,30,66
P6-13	Sugar	15,24,31,67
P6-14	Key	
P6-15	Neutral	
P6-16	Chocolate auger	34
P6-17	Chocolate whipper	33
P6-18	Soup whipper	35
P6-19	Tea brewer motor	29
P6-22	Coffee whipper motor	56,57,71

P7 MOTOR CONTROL TO LOGIC CONTROL INTERFACE

P7-1 24Vac hot
 P7-2 24Vac return
 P7-3 24Vdc hot
 P7-4 dc ground
 P7-5 -6.5Vdc measured to dc ground
 P7-6 ac present -6.5Vdc measure to dc ground P7-5
 -6.5Vdc will drop when to 0Vdc-when overflow bucket circuit is open
 P7-7 through 11 Data transfer lines

P8 WATER HEATER CIRCUIT

LOGIC LEVEL THERMOSTATS

P8-1 110Vac Top heater
 P8-2 Neutral
 P8-3 110Vac Bottom heater

P8 WATER HEATER CIRCUIT

DIRECT CONTROL THERMOSTATS

P8-1 Not used
 P8-2 Neutral
 P8-3 110Vac constant for both heaters

P10 GRINDER POWER

P10-1 Large grinder 110Vac-controlled by channel 4
 P10-2 Neutral for large grinder and swing out bracket

P11 110Vac IN TO MOTOR CONTROL BOARD FOR GRINDER AND HEATERS

P11-1 110Vac hot
 P11-2 110Vac neutral

LOGIC CONTROL BOARD PIN CONNECTIONS

P1 INTERCONNECT TO MOTOR CONTROL BOARD

- P1-1 24Vac hot
- P1-2 24Vac ground
- P1-3 24Vdc hot
- P1-4 dc ground
- P1-5 -6.5Vdc measured to dc ground
- P1-6 ac present -6.5Vdc measure to dc ground P7-5
-6.5Vdc will drop when to 0Vdc-when
overflow bucket circuit is open
- P1-7 through 11 Data transfer lines

P6 COIN MECHANISM

- P6-1 24Vdc return to pin 10 coin mech
- P6-2 Key
- P6-3 24Vdc hot to pin 12 coin mech
- P6-4 Key
- P6-5 Data line to pin 5 coin mech
- P6-6 Interrupt line to pin 4 coin mech
- P6-7 Accept Enable to pin 6 coin mech
- P6-8 Reset to pin 11 coin mech
- P6-9 Send line to pin 3 coin mech
- P6-10 5Vdc hot to pin 1 coin mech
- P6-11 dc ground to pin 2 coin mech
- P6-12 .05 dispense line to pin 9 coin mech
- P6-13 .10 dispense line to pin 8 coin mech
- P6-14 .25 dispense line to pin 7 coin mech

P15 BILL VALIDATOR

- P15-1 Escrow high
- P15-2 \$1 high
- P15-3 \$2 high
- P15-4 \$5 high
- P15-5 Escrow low
- P15-6 \$1 enable
- P15-7 \$2 enable
- P15-8 \$5 enable
- P15-9 Bill validator credit pulses
- P15-10 Key
- P15-11 Dc ground
- P15-12 24Vac hot
- P15-13 24Vac return
- P15-14 +15Vdc
- P15-15 +6.5Vdc

NOTE: THE FOLLOWING CONNECTORS ARE SENSORS ONLY AND ALL TESTING SHOULD BE DONE WITH POWER OFF AND CONNECTOR REMOVED FROM THE CIRCUIT BOARD. THE ONLY TEST THAT SHOULD BE DONE IS A CONTINUITY TEST TO CHECK THE SWITCH FOR CORRECT OPERATION.

P7 ELECTRONIC LIQUID LEVEL CONTROL VERSION 2 ONLY - SWITCH #40

- P7-1 To tank lid ground
- P7-3 Key
- P7-4 Tank probe

P9 BREWER CONTROL CIRCUIT

- P9-1 Brewer delay switch-SWITCH #35
- P9-2 Key
- P9-3 Common
- P9-4 Brewer cycle switch-SWITCH #34
- P9-5 Brewer water switch-SWITCH #33

P10 WATER TANK SENSORS

- P10-1 Common
- P10-2 Key
- P10-3 Water level switch-SWITCH #39-disables machine
'Out of Order' after water inlet switch operates
continuously for 90 seconds - Version 1 software

LOGIC LEVEL THERMOSTATS

- P10-5 Rear thermostat-SWITCH #37
- P10-6 Front thermostat-SWITCH #36

DIRECT CONTROL THERMOSTATS

- P10-5 Connected to P10-1 at tank-SWITCH #37
- P10-6 Not used-SWITCH #36

P11 DISCOUNT SWITCH-SWITCH #25

- P11-1 Common
- P11-2 Discount switch (N.O.)

P12 FLUSH INTERLOCK SWITCH-SWITCH #26

- P12-1 Common
- P12-2 Flush interlock switch (N.O.)

P13 CUP PRESENT SWITCH-SWITCH #28

- P13-1 Common
- P13-2 Cup present switch (N.C.)

P16 MODE SWITCH-SWITCH #30

- P16-1 Common
- P16-2 Mode switch (N.O.)

P17 CYCLE LED

- P17-1 Common
- P17-2 LED

LED PRINTED CIRCUIT BOARD PIN CONNECTIONS

- LP1-1 THRU 29 MEMBRANE SELECTION SWITCH
See pg 2.12 for pin connections

- LP2-1 THRU 25 INTERCONNECT TO LOGIC CONTROL

- LP3-1 THRU 7 SECURITY KEY SWITCH #29

SCHEMATIC - VERSION 1 SOFTWARE

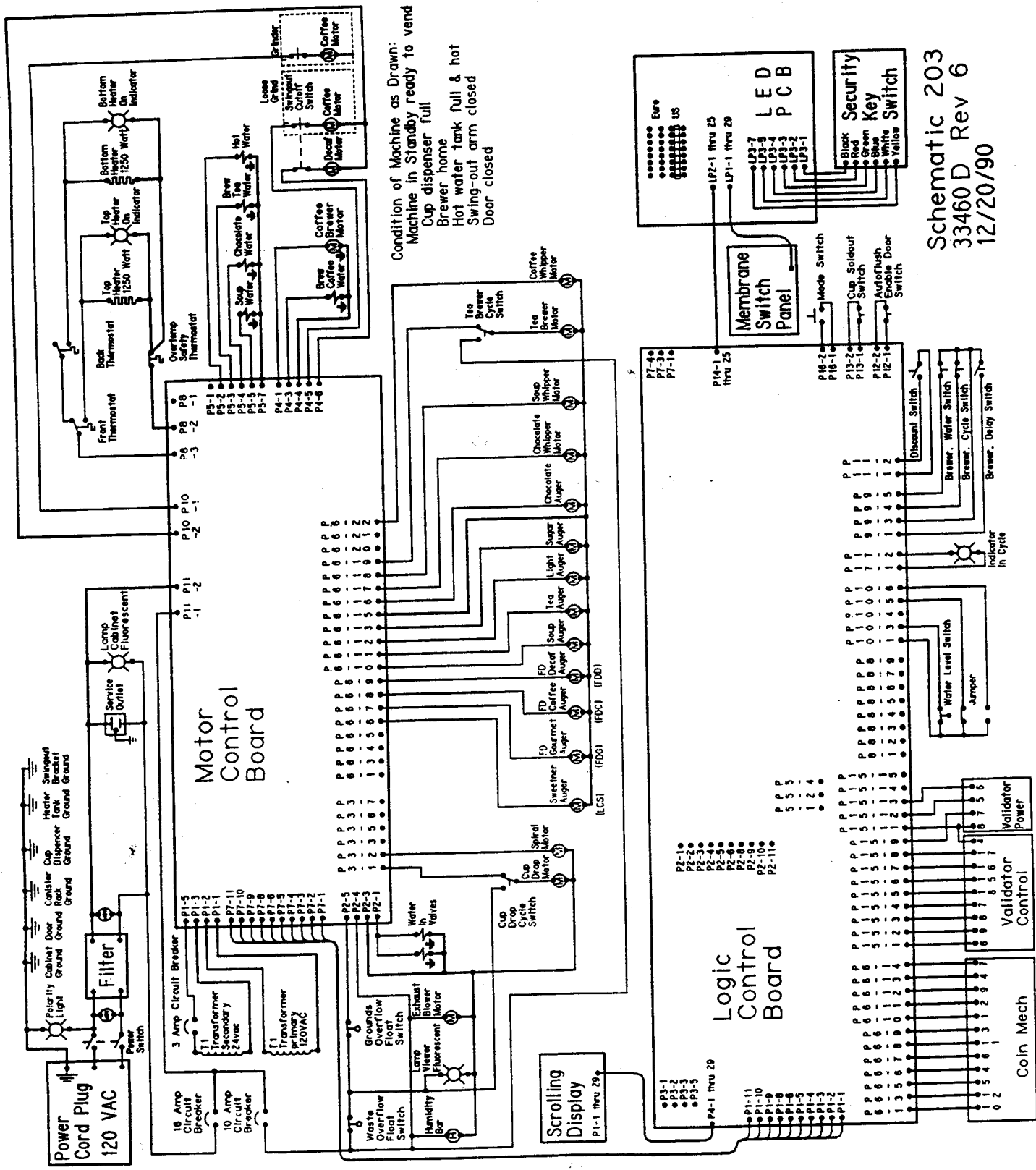

Condition of Machine as Drawn:
 Machine in Standby ready to vend
 Cup dispenser full
 Brewer home
 Hot water tank full & hot
 Swing-out arm closed
 Door closed

Schematic 203
 33460 D Rev 6
 12/20/90

SCHEMATIC - VERSION 2 SOFTWARE

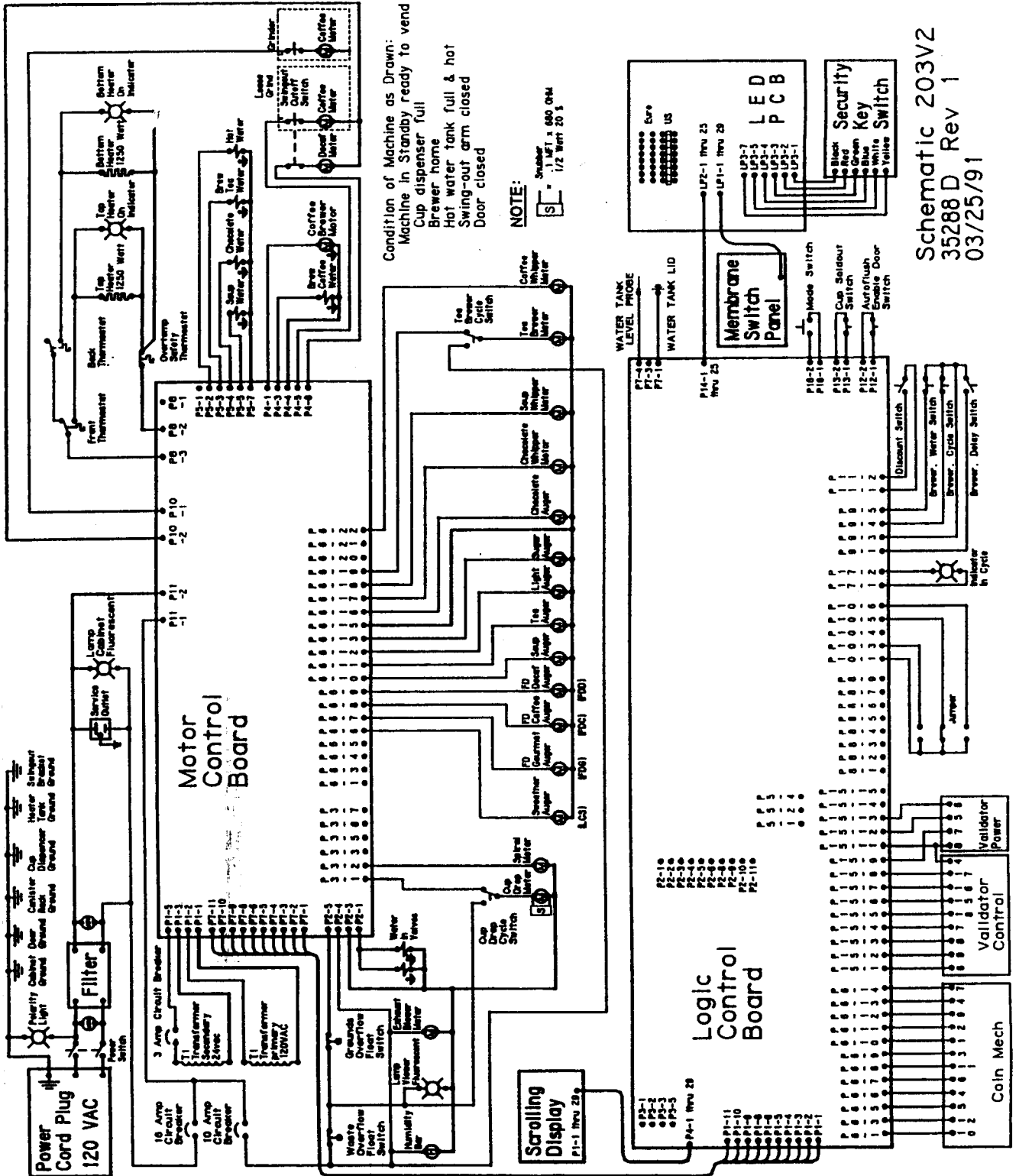

Schematic 203V2
 35288 D Rev 1
 03/25/91

