

FoodKing

Set-Up Guide

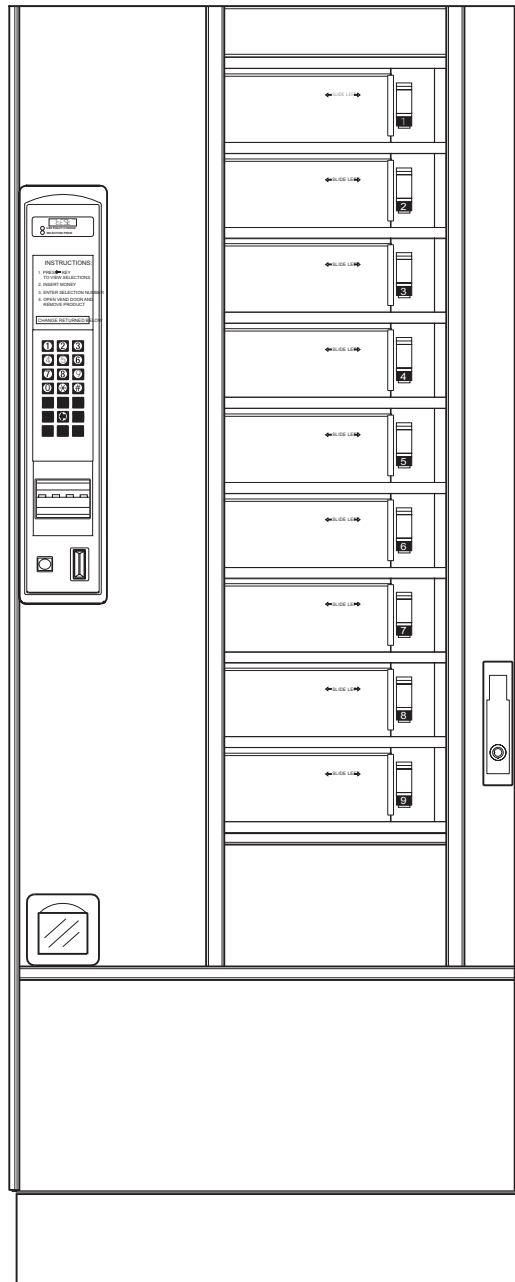

12955 Enterprise Way
Bridgeton, MO 63044-1200
(314) 298-3510

4290001

Copyright © 8-99

Food King Model 429 Setup Guide

Table of Contents

SPECIFICATIONS	3
INTERNAL PARTS LOCATION	4
INITIAL SET UP	6
Unpack And Inspect	6
Electrical Requirements	6
INSTALLATION	7
INSTALL THE COIN MECHANISM	8
INSTALL LABELS	9
INSTALL THE DOOR LOCK	10
LOAD THE MERCHANDISER	11
PROGRAMMING	12
Getting Around	12
The Selection Switch Panel	12
Special Programming Keys	12
The Displays	13
Standby Messages	13
Temperature And Health Control Display	13
The Mode Switch	14
Flowcharts	14
Data	15
Pay Out (Does Not Apply To Machines With Exec Coin Mechanisms.)	15
Price	16
Test	16
Faults	17
Configure	18
ROUTINE SERVICE AND SANITATION	20
General	21
Daily Service	21
Daily Sanitation	22
Weekly Service	22
Weekly Sanitation	22
Monthly Service	22
Monthly Sanitation	22
Semi-annual Service	23
Semi-annual Sanitation	23
Cleaning The Coin Validator And Coin Chute	23
Cleaning The Bill Validator	23
ADJUSTING THE PRODUCT DIVIDERS	24
ADJUSTING THE PRODUCT DIVIDERS (CONTINUED)	25
CLEARING A CAROUSEL JAM	25
TIMING THE CAROUSEL	26

Food King Model 429 Setup Guide

Notes . . .

Food King Model 429 Setup Guide

SPECIFICATIONS

DIMENSIONS:	Height - 183 cm (72 in.) Width - 73.6 cm (29 in.) Depth - 88.3 cm (34 ³ / ₄ in.)
WEIGHT:	266.3 kg (587 lbs.)
ELECTRICAL	
(U.S.):	115 Volts AC, 60 Hertz, 12 Amps, Single Phase
(INTERNATIONAL):	230 Volts AC, 50 Hertz, 6 Amps, Single Phase
REFRIGERATION:	Refrigerant - 134a Charge - 255 g (9 oz.)
MISCELLANEOUS:	Minimum ambient temperature 5° C (41° F) Maximum ambient temperature 32° C (90° F)

FOR INDOOR USE ONLY

SPECIAL OPERATING NOTES

- Once the customer makes a selection and the selection door is unlocked, that door can be closed and reopened for up to 30 seconds (with no additional money required). This condition is contingent on the turrent not being moved, or another selection made.
- The turret will automatically move approximately $\frac{1}{3}$ of a revolution every 30 minutes while the machine is idle. Any keypress will reset the 30 minute delay time.

Food King Model 429 Setup Guide

INTERNAL PARTS LOCATION

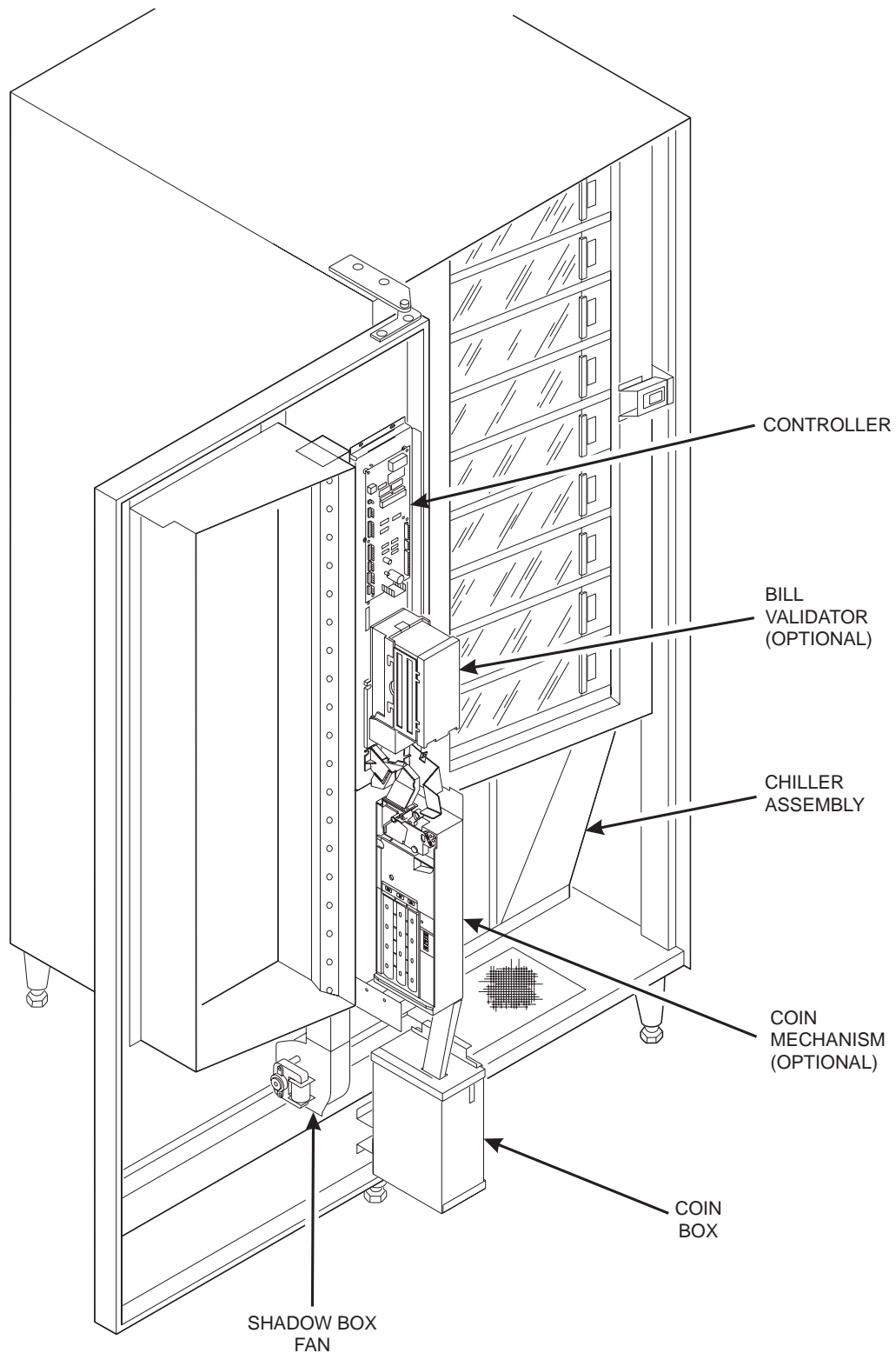

Food King Model 429 Setup Guide

INTERNAL PARTS LOCATION (CONTINUED)

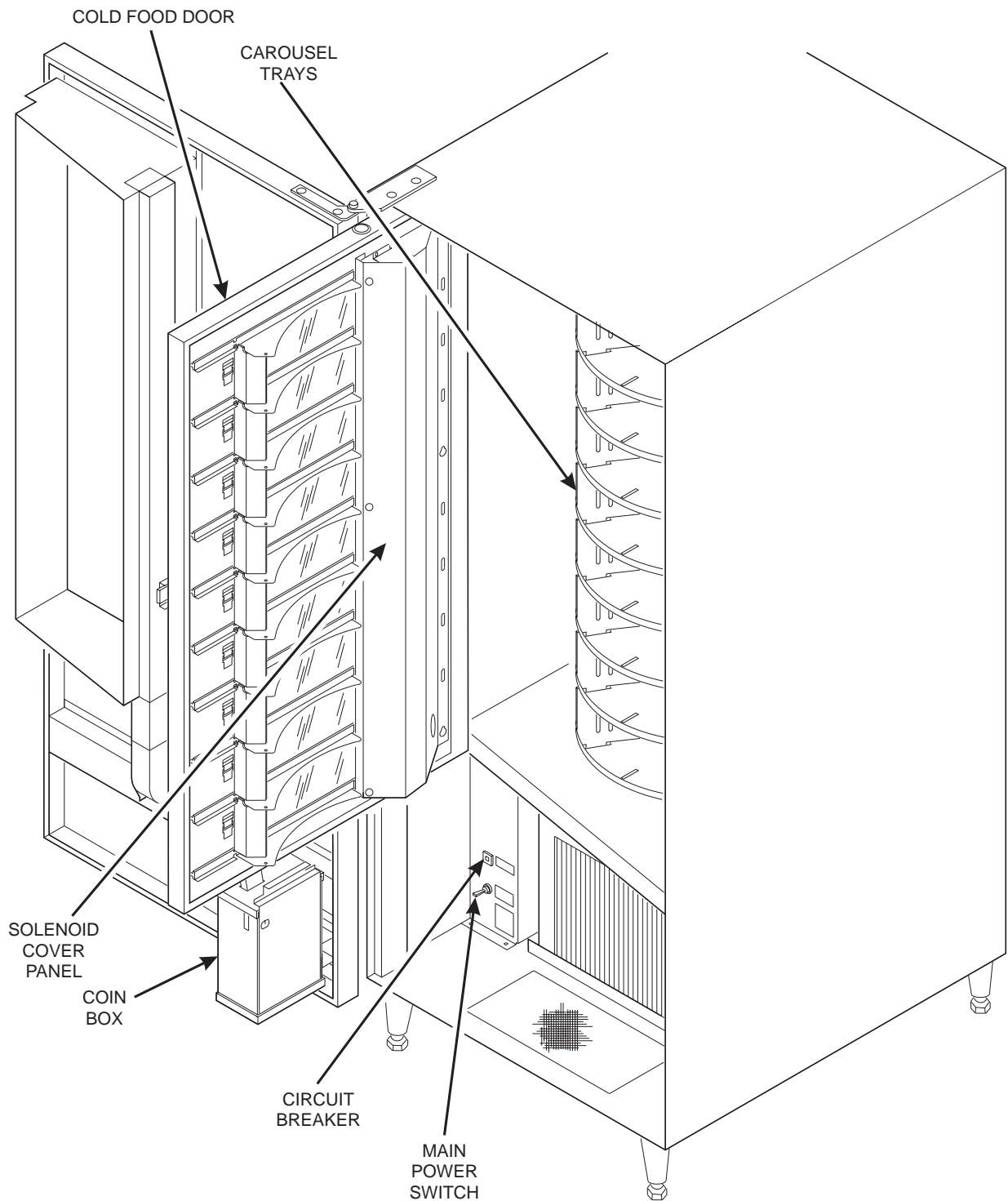

Food King Model 429 Setup Guide

INITIAL SET UP

UNPACK AND INSPECT

1. Carefully remove the merchandiser from its shipping carton and place it on a level surface.
2. Inspect the outside of the merchandiser for dents, scratches, or any damage resulting from improper handling.
3. If the merchandiser has the optional door lock, the key will be in the coin return receptacle.
4. Inspect the inside of the cabinet. Observe the location and position of the packing material should you need to reuse it. Carefully remove all packing material.

IMPORTANT

If you see any damage when you unpack the merchandiser, file a claim immediately with the carrier.

5. Instructions for installing the optional Base Plate are included with the Base Plate Assembly when shipped.
6. Inspect the merchandiser's electrical connectors and components.

ELECTRICAL REQUIREMENTS

The merchandiser is supplied with a service cord for the country of use and is terminated in a grounding type plug. The wall receptacle used on this merchandiser must be properly polarized, grounded, and of the correct voltage. Operating the merchandiser from a source of low voltage will **VOID YOUR WARRANTY**. Each merchandiser should have its own electrical circuit and that circuit should be protected with a circuit breaker or fuse conforming to local regulations.

Voltage Check - Place the test leads of a voltmeter across the LINE (LIVE) and NEUTRAL terminals of the wall receptacle. The meter should indicate 110 - 130 volts ac for 120 volt, 60 Hz locations, or 220 - 240 volts ac for 230 volt, 50 Hz locations.

Polarity Check - Place the test leads of a voltmeter across the LINE (LIVE) and GROUND terminals of the wall receptacle. The meter should indicate 110 - 130 volts ac for 120 volt, 60 Hz locations, or 220 - 240 volts ac for 230 volt, 50 Hz locations.

Noise Potential Check - Place the test leads of a voltmeter across the NEUTRAL and GROUND terminals of the wall receptacle. The meter should indicate 0 volts ac. A measurement greater than 1.5 - 2.0 volts ac could result in problems for the merchandiser's electronic circuitry caused by electrical noise.

Any deviation from these requirements could result in unreliable performance from your merchandiser.

Food King Model 429 Setup Guide

INSTALLATION

NOTE

This merchandiser is intended for INDOOR use only.

CAUTION

Make sure the merchandiser is properly leveled on a flat, solid, stable floor or base foundation. IF THIS IS NOT DONE, PERSONAL INJURY AND/OR DAMAGE TO EQUIPMENT MAY RESULT!

1. Move the merchandiser to the desired location.
2. Position the merchandiser at least 6 inches (15 cm) from any wall.
3. Using a spirit level, level the machine front to back and side to side.

NOTE

You may need to use pliers or channel locks to loosen the leg levelers.

4. For “bank style” installations of multiple merchandisers:
 - a. Position the first machine in the location, or at the highest spot if the floor is not level. Extend the leg levelers only as required to level the machine.
 - b. Position and level the remaining machines.
5. Set the main power switch to OFF.

IMPORTANT

Do not apply power to the merchandiser until you have done the power source checks outlined above. Possible equipment damage could result from improper supply voltage.

6. Plug in the merchandiser.
7. Turn the main power switch ON and close the cabinet door. The display lamp will light, and the shadow box fan motor will run.

Food King Model 429 Setup Guide

INSTALL THE COIN MECHANISM

WARNING

Make sure the main power switch is turned OFF before you work on the merchandiser. Failure to do so could result in death or injury.

1. Turn OFF the main power switch. Refer to the instructions provided with the coin mechanism and remove the coin validator assembly.
2. Loosen the coin mechanism mounting screws on the merchandiser so they stand off about 1/8" (0.3 cm).
3. Position the coin mechanism so the three keyed holes fit over the mounting screws. Pull down on the coin mechanism to seat the screws in the keyways.
4. Tighten the mounting screws and reinstall the coin validator.
5. Turn ON the main power switch. Select the correct type of coin mechanism in the CONFIGURE procedure.
6. The coins may be loaded into the tubes using either of the following procedures:
 - a. **High accuracy coin counting method (recommended):** Enter the TEST procedure. Insert enough coins through the coin slot to cover the empty sensor. The amount of coins inserted will be internally recorded.
 - b. **Quick fill method:** Insert enough coins through the coin slot to **COMPLETELY FILL** the tubes. OR For coin mechs with removable tube cassettes, remove the cassette and fill the tubes directly. Replace the cassette.
7. Enter the TEST procedure. Using one coin of each tube denomination, insert all the coins through the front panel coin insert slot. Press the coin return and verify that the same coin denominations are returned.
8. Visually check the coin tubes to make sure coins are lying flat.

Food King Model 429 Setup Guide

INSTALL LABELS

A SET OF "LOCATE FOOD HERE" LABELS ARE LOCATED IN THE PLASTIC BAG ASSEMBLY THAT CONTAINED THIS MANUAL. PLACE ONE LABEL ON EACH OF THE VEND DOOR GUIDES. POSITION THE LABEL SO IT IS CENTERED UNDER THE VEND COMPARTMENT.

LOCATE FOOD HERE

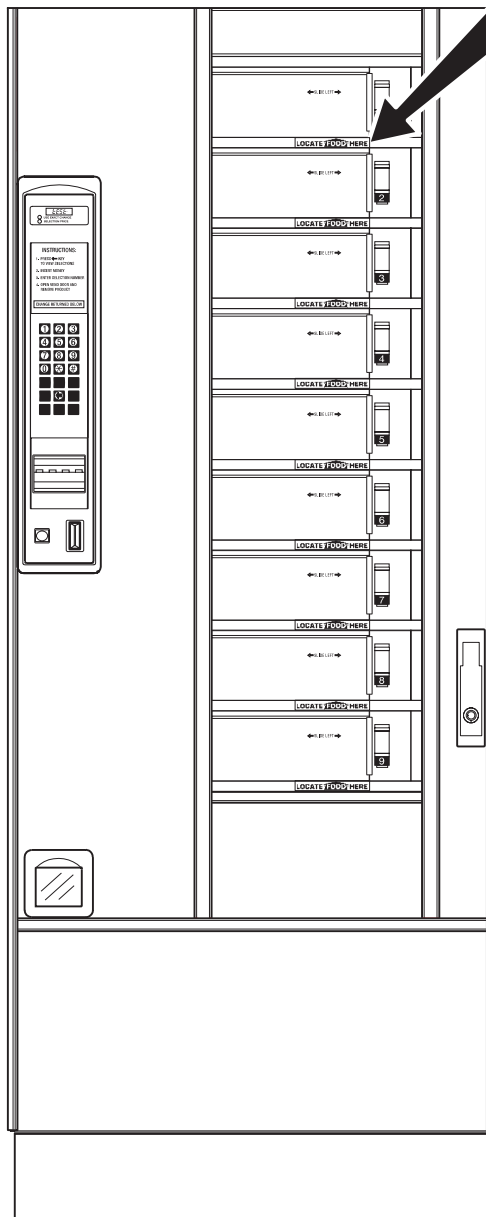

NOTE:
BEFORE APPLYING LABEL,
CLEAN AND DRY THE SURFACE
OF THE VEND DOOR GUIDE.

Food King Model 429 Setup Guide

INSTALL THE DOOR LOCK

There are two optional door locks:

FLEX-ACE (P/N 9992000)

- a. Corresponding key
- b. (P/N 9994000)

VAN LOCK (P/N 3112163)

- a. Corresponding key
- b. (P/N 3112164)
- c. Lock and key kit (P/N 3122165)

Install the door lock as follows:

1. Remove the lock spring.
2. Depress the lock pin and push the lock cylinder in the lever until the pin snaps into place.
3. Test the lock mechanism with the key.

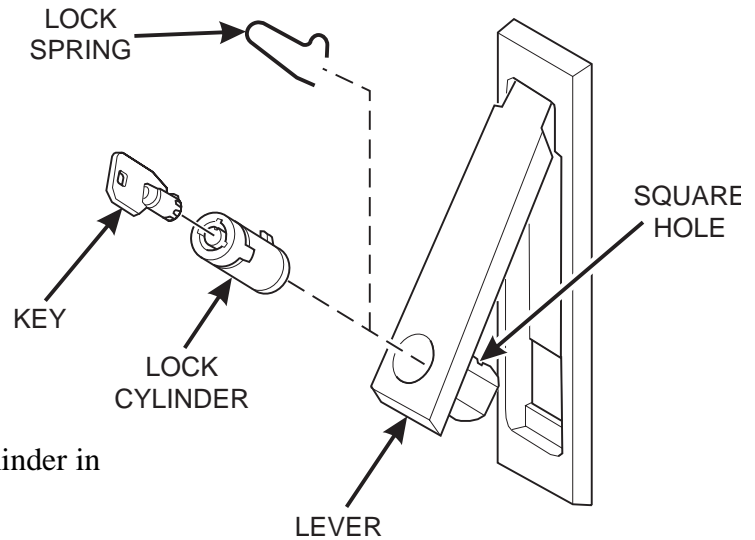

Food King Model 429 Setup Guide

LOAD THE MERCHANDISER

1. Adjust the product dividers, if necessary.
2. Set new prices, if desired.

NOTE

If the food carousel is loaded with items which are too large for the compartments, the carousel will not rotate properly.

3. Load any empty compartments.
4. Push in the load switch until the carousel rotates enough to expose more empty compartments.
5. Repeat steps 3 and 4 until the carousel is fully loaded.
6. Close the door.

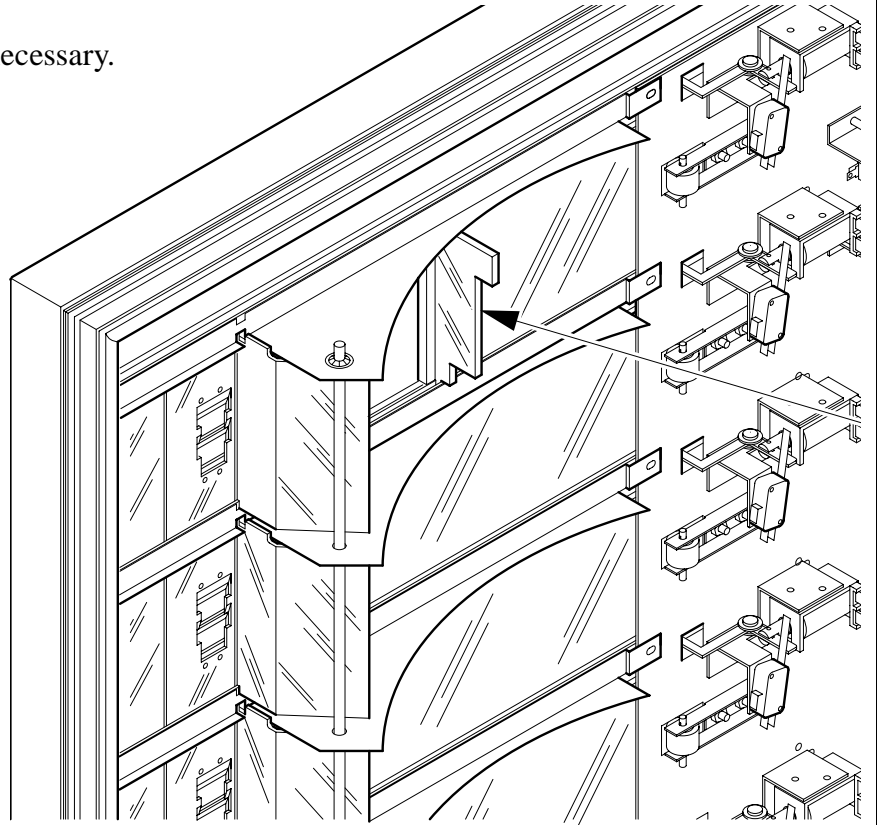

Food King Model 429 Setup Guide

PROGRAMMING

GETTING AROUND

Getting around the FoodKing software is pretty easy once you know the features that are available to you, and how to use them. The three main parts you will use are the SELECTION SWITCH PANEL, the DISPLAY, and the MODE switch.

The Selection Switch Panel

The selection switch panel is located on the monetary panel. These are the keys customers use to make selections, but you will use these keys during programming procedures.

Special Programming Keys

Some keys on the panel have jobs that only show up during programming. Three of them do not even appear on the panel, but they are active during programming, so the keypad shown at right is what you will be using. To help you remember the keys, this panel will be shown on each page in the programming section.

- ① Press this key to move from one function to another.
- ② From within a function, press once to return to the beginning of the function; press and hold to return to the standby message.
- ③ This key moves you around inside of a function.
- ④ This key allows you to switch between two or more choices.
- ⑤ This is the "action" key. It will start tests, etc.
- ⑥ This key is used to clear certain data or errors.

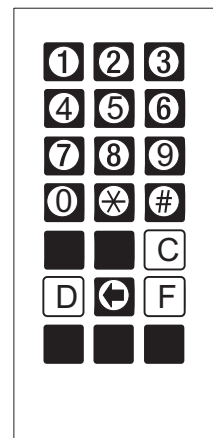

427P0014

Food King Model 429 Setup Guide

THE DISPLAYS

The display group consists of a 4-character digital display which performs two functions, and is referred to in this book as "the display":



427P0011

1. It shows the customer's selection and how much credit is in the machine, as well as the standby message.
2. It provides information and feedback to the service person during maintenance.

STANDBY MESSAGES

Several standard messages (called "standby messages") are displayed under certain circumstances:

- . 0 0 = This is the normal display. The numbers will change when credit is added.
- 0 0 t O F 0 r d r = This is a fatal error - the machine will not run. See the error list.
- d o o r O P E N = A vend door is not closed all the way. This will not appear until several seconds after a vend.
- 4 0 ° F = Shown in the display (zero credit and no errors), if this option is chosen.

TEMPERATURE AND HEALTH CONTROL DISPLAY

Pressing (#) displays the temperature from any standby message. Some of the following conditions may appear::

- 4 0 ° F . = The trailing decimal point means that the compressor is running.
- 4 0 ° ? = The question mark represents an invalid temperature (temperature sensor error).
- 4 8 ° F 2 8 M = This means that the health control grace period has 28 minutes remaining. The machine must be able to reach an internal temperature of 45°F (7.2°C) within 30 minutes of door closure. The grace period can be reset to 30 minutes by opening and closing the cold food door. To test the health control, open the door and hold the temperature sensor. The machine should go out of order.

NOTE

All displays shown in degrees Fahrenheit (°F) may be replaced by their equivalents in degrees Celsius (°C), depending upon how you have configured your machine.

Food King Model 429 Setup Guide

The display group also contains two lamps which light up under certain conditions:

1. The "USE EXACT CHANGE" lamp lights when there are insufficient coins in the merchandiser to provide change for a vend. You can set the criteria for this condition in the programming section.
2. The "SELECTION PRICE" lamp lights when the customer has inserted insufficient credit into the machine to vend the selected product. In conjunction with this lamp lighting, the selection's price flashes in the digital display.

NOTE

During programming modes, these lights blink whenever a key is pressed as a test of the lamps.

THE MODE SWITCH

All programming procedures begin with this switch. Until you push the switch, the special programming keys will not work, especially the "invisible" keys.

The MODE switch is a large square white button located on the rear of the controller board as shown.

FLOWCHARTS

Think of a flowchart as a "roadmap" to the programming functions (contained on the pages following the flowcharts). Once you become familiar with the programming procedures, you can use the flowcharts as a quick reference.

The boxes represent the different functions, and the symbols between the boxes represent the keys you need to press in order to move between the functions.

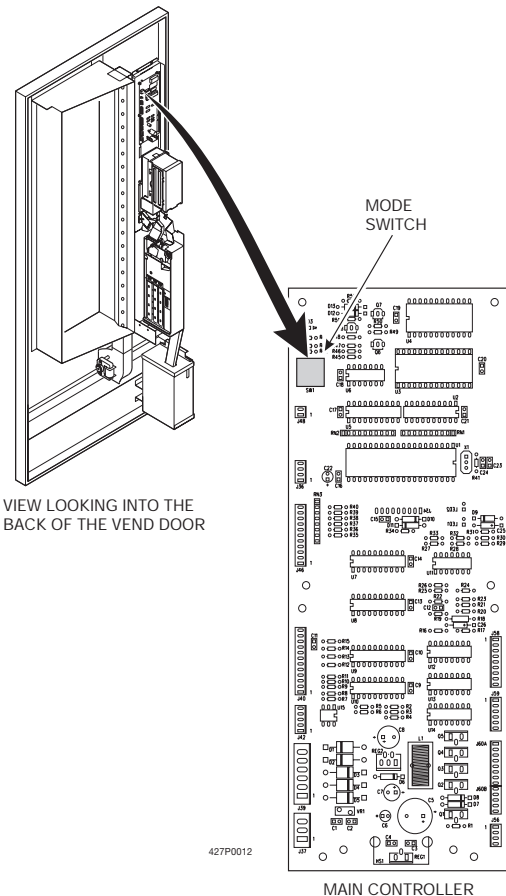

Food King Model 429 Setup Guide

DATA

View several types of sales data:

NOTE

All data is not resettable.

1. Press the **MODE** switch on the main controller.
2. Press **#** until the display shows **CASH**. The display will flash the total cash sales:

CASH...XXXX...XX.XX

3. If you have the DEX option, press **D** to transfer data into your DEX device.
4. Press *****. The display shows **- | -**, then flashes 4 to 8 digits. This is the dollar and cents amount of door 1 sales.
5. Press ***** to view cash sales for doors 2 through 9.
6. Press **#**. The display shows **CNT**. The display will flash the total vend count:

CNT...XXXX...XXXX

7. Press *****. The display shows **- | -**, then flashes 4 to 8 digits. This is the number of door 1 vends.
8. Press ***** to view vends for doors 2 through 9.
9. Press **#** to exit.

PAY OUT (Does not apply to machines with exec coin mechanisms.)

Pay out coins:

1. Press the **MODE** switch on the main controller.
2. Press **#** until the display shows **PAY**. Press **1** to pay out nickels, press **2** to pay out dimes, and press **3** to pay out quarters. Press **4** to pay out from the 4th MDB tubes.
3. Press the appropriate key once to pay out one coin.
4. Press and hold the appropriate key to pay out coins continuously.
5. Press and hold **#** to return to the standby message.

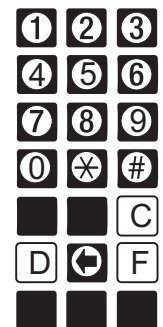

427P0014

Food King Model 429 Setup Guide

PRICE

Set prices for all the selections in your merchandiser:

The price display:

- - ... changes to25

↑ ↑

Door number Selection price

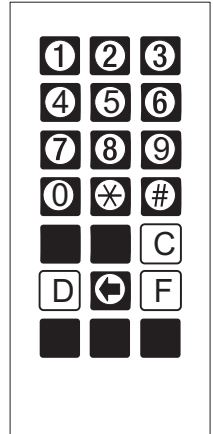

427P0014

1. Press the MODE switch on the main controller.
2. Press **#** until the display shows P r c.
3. Press *****, and the display shows - 1 -, then .XX. "XX" is the price for door number 1.
4. Press ***** until the selection you want to price is displayed.
5. Enter a new price with the number keys.
6. Repeat steps 4 and 5 until you have priced all the selections.

OR

7. Press **#** to return to the P r c display, or hold **#** to exit.

TEST

View machine status and test certain functions:

1. Press the MODE switch on the main controller.
2. Press **#** until the display shows t E S t.
3. Make a selection and open the door (if you deposit money, the credit is shown in the display). The selection number flashes momentarily in the display to indicate the door solenoid activates. This is followed by the number with two dashes: Example, - 1 - for selection #1. The dashes indicate that the door switch is made.
4. Do not close the door yet. You can either wait 12 seconds. The display shows - 0 -, indicating that the vend timer has timed out. OR, you can press **0** rather than wait the 12 seconds. The display will still indicate that the machine recognizes that the door has not closed. In this condition, the carousel will not rotate.
5. The display returns to t E S t when the door is closed.
6. Repeat steps 3 and 4 for the remaining doors.
7. Press and hold **#** to return to the standby message.

Food King Model 429 Setup Guide

FAULTS

Display all the active faults on your merchandiser:

1. Press the MODE switch on the main controller.
2. Press until the display shows `E r r`. **Note:** If no faults are present, this will not be displayed.
3. If errors are present, press `*` to see the list of faults:

`E r U 3` The EPROM is bad.

`E r U 4` RAM is not initialized or is not compatible with the currently loaded software. If this message appears, initialize your RAM by performing the following procedure:
NOTE: Initializing RAM will erase all your data. Be sure you have written this information down before continuing.

Press AND HOLD `C`. You will see `c L r` in the display. Continue holding until the display shows `d 0 n E`.

`H C E r ...XX ° F` The health control has been set. "XX°F" is the maximum temperature reached.

`t . r E F` The temperature reference on the main PCB cannot be read.

`t . S n S` The temperature sensor cannot be read.

`t . r n G` The temperature sensor is out of range.

`E r . b L` Problem with the bill validator.

`E r . C d` Problem with the card reader.

`E r . C n` Problem with the coin mechanism.

`n 0 n E ...r d y` All selections are out of service.

`E . P r c` Illegal price is detected. Clear by checking prices.

`J 5 8 .` Cannot read switch inputs. Disconnect J58 at the main controller and scroll through the error list. If the error persists, replace the main controller. Otherwise, check the switch harnesses.

`E r . d X` Did not read the vend door lock switch when door solenoid X was energized.

When the first fault item (if any) repeats, you have seen all the faults.

4. Press `*` to see more faults or `#` to exit.

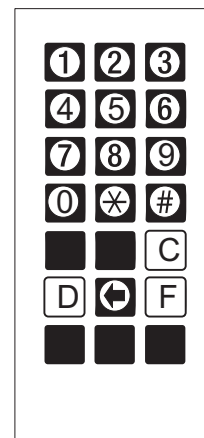

427P0014

Food King Model 429 Setup Guide

CONFIGURE

Configure various machine functions:

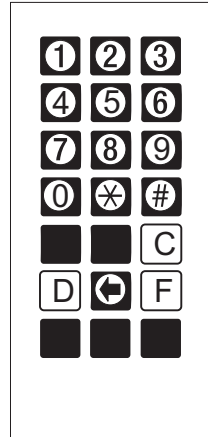

427P0014

1. Press the MODE switch on the main controller.
2. Press **#** until the display shows $\text{C } 0 \text{ F}$.
3. Press *****. The display shows the coin mechanism options:

$\text{C } n, d$ = dumb mech

$\text{C } n, \text{fl}$ = MDB

$\text{C } n, E$ = Exec mech

$\text{C } n, 0$ = No mech

Press **F** to switch between the coin mech choices.

4. Press *****. The display shows the bill validator options:

$b L, P$ = Pulse validator (not supported at this time)

$\text{fl}, 1, 2, 5$ = MDB validator. Press **1**, **2**, or **5** to enable/disable acceptance of that denomination bill.

$\text{fl}, d,$ = MDB validator with additional bill selections

Press **D** to enter a list of bills. Two alternating screens appear:

$1, 0 \text{ fl}$ = Channel 1 and bill is enabled

$1, 0 0$ = Bill denomination

Press **F** to set bill acceptance ON or OFF

Press ***** to scroll through the list of bills

Press **#** to move up to the top level screen when finished

$b L, 0$ = No validator

$\text{C } P \text{ fl}$ = coupon bills

5. Press *****. The display shows the card reader options:

$\text{C } d, d$ = Dumb

$\text{C } d, \text{fl}$ = MDB

$\text{C } d, 0$ = No card reader

6. Press *****. The display shows $\text{C } .XX$. Change will be given for coins or bills up to this amount without the customer having to make a selection. For example, if **1.00** is displayed, the machine will give the customer change for a dollar without requiring a selection. Entering **0.00** means that no change will be given.

Food King Model 429 Setup Guide

7. Press **(*)**. The display shows: $\text{E}X.XX$. The customer will see the USE EXACT CHANGE lamp lighted when the amount of available change in the coin mechanism falls below the level you set for $X.XX$. Enter a value with the number keys. For example, if $\text{E}1.00$ is selected, the customer sees the USE EXACT CHANGE lamp when less than a dollar's worth of change is in the mechanism.

8. Press **(*)**. The display shows either:

db, on = More than one vend is allowed, with a declining balance. This means that the customer can choose multiple products until the amount of credit is lower than the lowest priced product in the machine.

OR

db, off = A declining balance is not allowed. Press **(F)** to switch between these two choices.

9. Press **(*)**. The display shows $XX^{\circ}F$. This is the machine temperature setpoint.

Press **(1)** to increase through the allowed temperature range (in $1^{\circ}F$ steps).

Press **(0)** to return to the factory setpoint.

Press **(F)** to change display units from $^{\circ}F$ to $^{\circ}C$.

Press **(D)** to display temperature in the standby message. A trailing decimal point is displayed if this option is selected.

10. Press **(*)**. The display shows the machine ID number. This number is sent to a DEX device when transferring data.

11. If not present, enter the 6-digit machine ID number with the number keys. The number will fill in from the right.

Food King Model 429 Setup Guide

ROUTINE SERVICE AND SANITATION

Sanitation is an important phase of merchandiser operation. The lack of proper service and sanitation can cause merchandiser malfunction and loss of sales.

The periods and suggested procedures for service and sanitation are daily, weekly, monthly, and semi-annually. These periods and procedures are given as guides only, and are not to be construed as absolute or invariable. Local conditions must always be taken into consideration. Certain installations require that some or all of the steps under Monthly Service and Sanitation be performed weekly. Each merchandiser must be maintained individually in accordance with its particular requirements. We, however, stress **"A CLEAN MERCHANDISER IS THE MOST PROFITABLE MERCHANDISER"**.

Sanitizing means effective bactericidal treatment of clean surfaces of equipment and utensils by a process which has been approved by the health authority as being effective in destroying microorganisms, including pathogens.

Sanitizing processes generally accepted by the health authority are as follows:

1. Immersion for at least one-half minute in clean hot water at a temperature not lower than 170° F (77° C).
2. Immersion for a period of at least one minute in a sanitizing solution containing:
 - a. At least 50 ppm of available chlorine at a temperature of not lower than 75° F (24° C); or
 - b. At least 12.5 ppm of available iodine in a solution having a pH not higher than 5.0 and a temperature not lower than 75° F (24° C); or
 - c. Any other chemical-sanitizing agent which has been proven to be effective and non-toxic under usage conditions, and for which a suitable field test is available.

The following warnings and cautions are applicable to the service and sanitation procedures given in this section:

CAUTION

Milk and other foods are perishable products. Follow local health authorities' rules and regulations for storage and handling of these items.

IMPORTANT

All loose food particles or spillage, whether wet or dry, must be removed from the inside and outside of the merchandiser.

CAUTION

Do not get electrical connections or electrical components damp or wet.

NOTICE

Do not use waxes or lubricants which contain silicone on or in the merchandiser. Silicone or silicone vapors can cause electrical failure.

Food King Model 429 Setup Guide

GENERAL

Set the main power switch OFF before cleaning or servicing the merchandiser. Use aerosol spray cleaners or spray waxes only in well-ventilated areas. NEVER use any spray product containing silicone. Silicone sprays can coat electrical contacts, causing a machine malfunction.

WARNING

Before using any liquid cleaner, unplug the merchandiser power cord or shut off power to the wall receptacle to avoid any possibility of electrical shock. Make certain all components are thoroughly dry and properly installed before restoring power.

Refer to the Parts Manual for additional service information and replacement parts. For factory assistance, contact the nearest service representative.

Contact the local health authorities and obtain their acceptance of the sanitizer you intend to use when cleaning and sanitizing the merchandiser.

When cleaning and sanitizing the merchandiser, use CLEAN, DISPOSABLE PAPER WIPES rather than cloths.

DAILY SERVICE

1. Replace burned-out or discolored light bulbs.
2. Replenish coin tubes in the coin mechanism.
3. Empty the bill validator.
4. Test vend the merchandiser.
5. Check the temperature of the cabinet.
6. Follow the daily sanitation procedures, then reload the merchandiser.

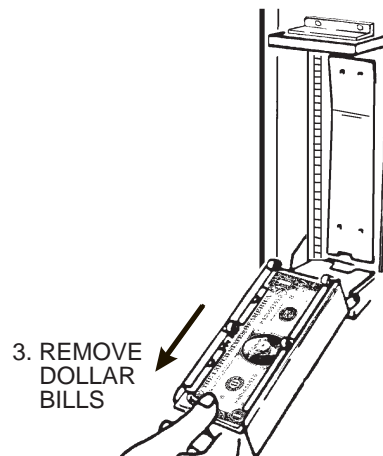
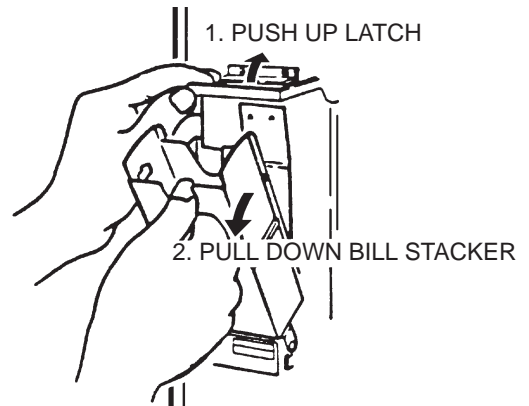

Food King Model 429 Setup Guide

DAILY SANITATION

1. Remove all past-date merchandise from the merchandiser.
2. Check for liquid spillage on the merchandiser modules. If there is spillage, remove the module shelves and dividers affected. Wash and sanitize the shelves and dividers with a clean, damp disposable paper wiper or a clean soft-bristle brush. Rinse with clean hot water and dry thoroughly.
3. Wipe the exterior of the merchandiser with a damp disposable paper wiper and dry thoroughly.
4. Fill in the appropriate columns on the record of cleaning card.

WEEKLY SERVICE

1. Follow the daily service instructions.
2. Brush the vent screens.
3. Inspect the refrigeration screen. Remove any accumulated dust.
4. Inspect the coin mechanism, coin validator, and bill validator. Clean if necessary.

WEEKLY SANITATION

1. Follow the daily sanitation instructions.
2. Inspect the merchandiser for overall cleanliness, especially the corners.
3. Wash and sanitize the merchandiser food compartment with a clean, damp disposable paper wiper. Dry thoroughly.
4. Fill in the appropriate columns on the record of cleaning card.

MONTHLY SERVICE

1. Follow the weekly service instructions.

WARNING

Be sure the area is well ventilated and no open flames are present before using any aerosol spray can.

WARNING

Use protective glasses or a protective shield if an air hose is used for drying.

2. Clean the coin chute and coin validator.
3. Clean the bill validator.
4. Remove the screen assemblies. Clean the screens with a dry cloth, then wash with a warm detergent solution. Rinse, dry, and reassemble.

MONTHLY SANITATION

1. Follow the weekly sanitation procedures.
2. Fill in the appropriate columns on the record of cleaning card.

Food King Model 429 Setup Guide

SEMI-ANNUAL SERVICE

1. Follow the weekly service instructions.
2. Inspect the merchandiser for worn parts and replace where necessary.

NOTICE

Do not use silicone lubricants. Silicone can cause electrical contact failures.

We recommend using Lubriplate Portable Tool Grease No. 905 (or equivalent), available from:

Industrial Lubricating Company, Inc.
P.O. Box 3871
St. Louis, MO 63122

3. Lubricate all moving parts that do not come into contact with food.

SEMI-ANNUAL SANITATION

1. Follow the monthly sanitation instructions.

CLEANING THE COIN VALIDATOR AND COIN CHUTE

Inspect the coin validator and coin chute at regular intervals. Clean them on approximately a monthly schedule.

1. Remove the coin validator assembly from the merchandiser.
2. Clean the coin chute with a tube cleaning brush to remove any accumulated dust and foreign matter.
3. Refer to the coin validator instruction booklet and follow the recommended cleaning procedure.

CLEANING THE BILL VALIDATOR

1. Refer to the bill validator instruction booklet and follow the recommended cleaning procedure.

Food King Model 429 Setup Guide

ADJUSTING THE PRODUCT DIVIDERS

Add or remove product dividers to accommodate various size products. Each tray segment can be left alone or divided into as many as 6 compartments, allowing the machine to vend up to 12 products per level.

Proceed as follows:

1. Remove tray segment:
 - a. Align the carousel as shown.
 - b. Pull down on the spring clip to release the pin.
 - c. Pull the tray segment directly out from the center.

2. Adjust tray divider:
 - a. Loosen all the retainer screws.
 - b. Remove all of the metal retainers.
 - c. Remove the plate holder.
 - d. Remove, add, or move tray dividers as needed.
 - e. Reassemble the tray segment in the reverse order of disassembly.

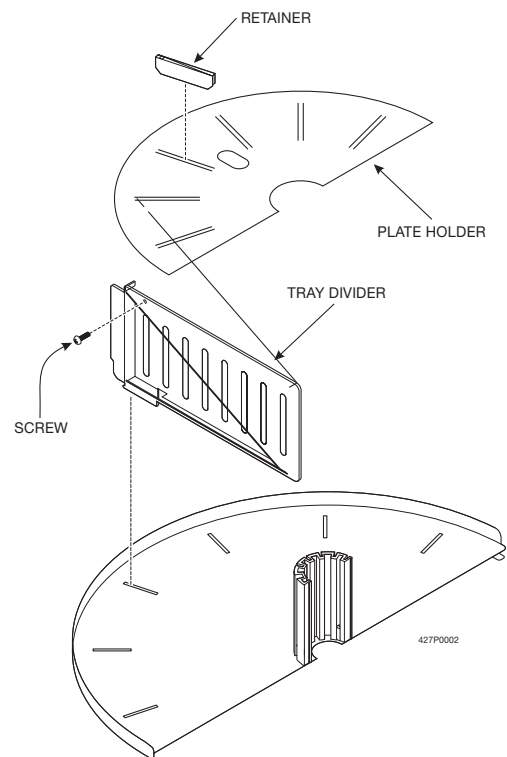
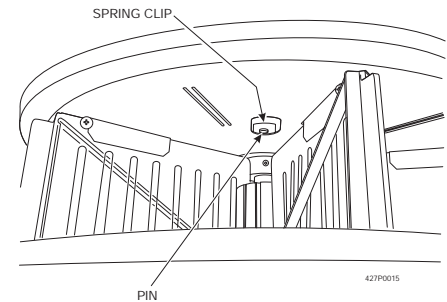
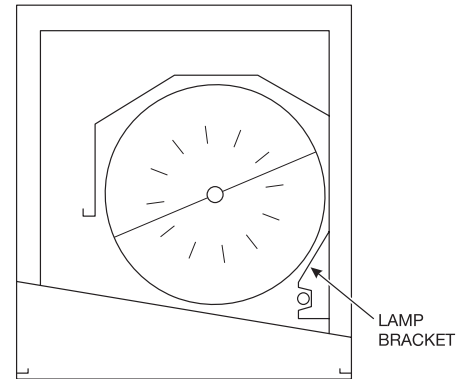

Food King Model 429 Setup Guide

ADJUSTING THE PRODUCT DIVIDERS (CONTINUED)

3. Install tray segment:
 - a. Make sure the carousel is still aligned as shown.
 - b. Carefully move the tray segment into position. Make sure the tabs on the ends of the tray segment line up with the tabs on the mating tray segment.
 - c. Pull down the spring clip in order to allow the pin to seat into the hole in the spring clip.
 - d. Push the tray segment the rest of the way home.
 - e. Check to be sure that the tray segment is secure and will not come out.

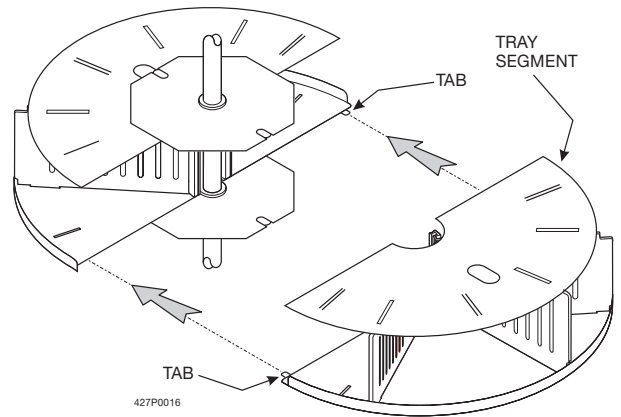

CLEARING A CAROUSEL JAM

1. Turn the main power switch OFF.
2. Manually push in the brake. Manually turn the carousel until you can remove the cause of the jam.
3. Close the door and move the carousel and ensure that all tray dividers will align with the right side of the vend doors.

Food King Model 429 Setup Guide

TIMING THE CAROUSEL

The tray dividers should be aligned with the adjacent edge on the vend door stop. If they are not aligned properly, follow the steps listed below:

1. Turn the main power switch OFF.
2. Remove the chain guard cover and the motor cover.
3. Verify that the motor is positioned so that the switch lever is bottomed out in one of the two cam detents. (This determines the motor's stop position. You may have to release the brake and manually move the carousel.)
4. Loosen the wing nut on the carousel motor and bracket assembly.
5. Support the chain to keep it engaged on the carousel motor sprocket.
6. Hold the chain motionless while rotating the carousel (work the chain around the carousel sprocket). Continue rotating the carousel until the tray dividers are aligned with the adjacent edge on the vend door stop.
7. Apply tension to the chain by tightening the wing nut on the carousel motor and bracket assembly. **MAKE SURE THAT THE CAROUSEL DOES NOT ROTATE WHILE TENSIONING. DO NOT OVERTIGHTEN THE CHAIN, OR THE CAROUSEL MOTOR MAY BIND.**
8. Close the cold food door and verify the alignment.
9. Install the covers you removed in step 2.
10. Return the machine to service.

