

VS-99

MODELS

"B" AND "C"

LEKTRO-VEND®

SERVICE MANUAL

CAPACITY/CONFIGURATION CHART

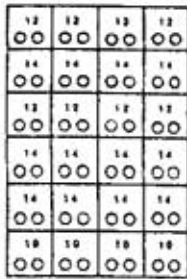

Model B24E
24 Selections
Shelf Capacity 304

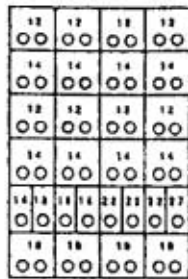

Model B28E
28 Selections
Shelf Capacity 409

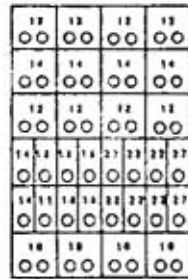

Model B32E
32 Selections
Shelf Capacity 514

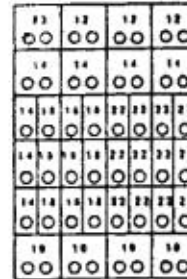

Model B36E
36 Selections
Shelf Capacity 627

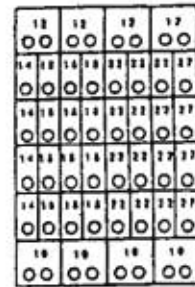

Model B40E
40 Selections
Shelf Capacity 732

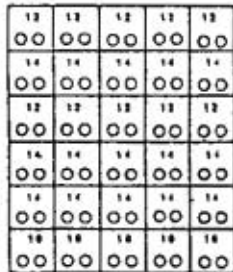

Model C30E
30 Selections
Shelf Capacity 380

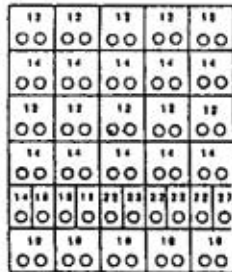

Model C35E
35 Selections
Shelf Capacity 515

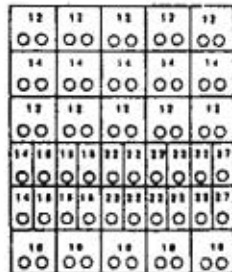

Model C40E
40 Selections
Shelf Capacity 650

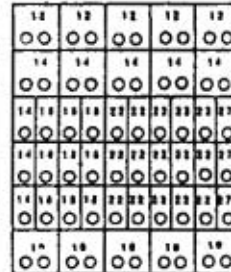

Model C45E
45 Selections
Shelf Capacity 795

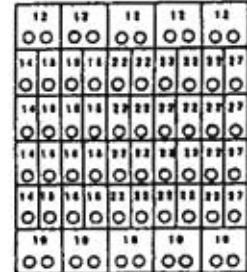

Model C50E
50 Selections
Shelf Capacity 930

LEKTRO-VEND VS-99 SERIES MODELS B AND C

GENERAL

The Lektro-vend Automatic Helix Merchandiser has independent dispensing units, with each helix activated by letter and number push buttons. The dispensing assemblies are installed on a shaft drive assembly. The dispensing units are supplied with helices of various pitches to accommodate a wide range of products. For the various configurations that are available see the configuration chart on page 2.

HEIGHT

VS-99 B	72"
C	72"

WIDTH

VS-99 B	34 1/2"
C	40"

DEPTH

VS-99 B	35"
C	35"

SHIPPING WEIGHT

VS-99 B	(APPROX) 560 LBS.
C	(APPROX) 630 LBS.

ELECTRICAL SPECIFICATIONS

PRIMARY VOLTAGE	110VAC
SECONDARY VOLTAGE	24VAC
MAXIMUM CURRENT	3AMP
VOLTAGE TO CHANGER	24VAC
VOLTAGE TO VALIDATOR	24VAC

INSTALLATION

- Remove all external packing material.
- Inspect equipment for shipping damage. If evident file claim immediately with the carrier (see Shipping Procedures).
- Remove keys from product dispensing compartment (in manila envelope), unlock the service door and remove any shipping material.
- Check the operation of the service door and locking mechanism. They should operate smoothly and latch at all three locking plates.
- If optional Gum & Mint installed, slide the shipping clip to the left located on the left side of the gum and mint assembly. Release the tray on the right side with the latching clip and slide the tray out and in to ensure that everything slides smoothly.
- Place machine into position and adjust leveling legs so the machine is level and all the legs sit firmly on the floor.
- Install changer and validator (if required) in machine.
- Plug service cord into 110VAC source using the three prong grounded plug provided. If a grounded outlet is not available, use a proper external ground on all locations.

NOTE: In order to comply with electrical safety regulations and Underwriters Laboratories requirements, all electrical equipment must be properly polarized and grounded. The Lektro-vend machine is wired so that it is properly polarized in accordance with the electrical code. If the wall outlet is wired and grounded properly, then the vending machine will connect properly.

Shown in views A and B are two properly grounded and polarized wall outlets. One is a three wire grounded type wall outlet (See View A) and the other is a two wire wall outlet (See View B) with an adapter in place.

Should the polarity at the wall outlet appear any way other than that shown below, the outlet should be rewired by qualified personnel.

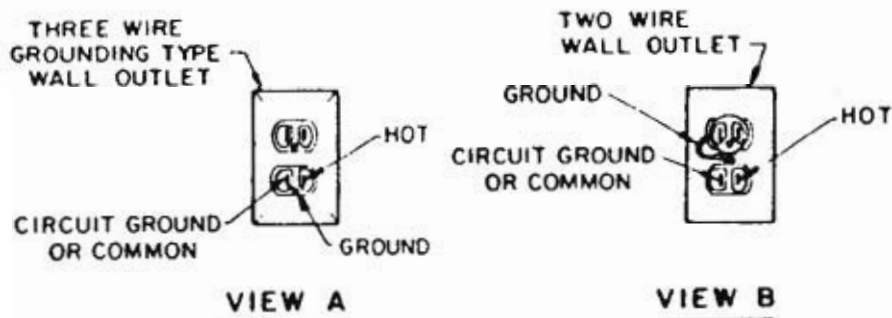

CAUTION: DISCONNECT POWER TO THE VENDING MACHINE BEFORE REMOVING THE CONTROL BOARD OR COIN CHANGER OR WORKING ON ANY COMPONENTS IN THE MACHINE.

- Check to ensure that the power present 24 VAC indicator light is illuminated on the right hand side of the control board located on the inside front door of the machine.
- Test the coin mechanism to ensure smooth operation. If the operation is not smooth, check to make sure that you have proper alignment of the changer with the coin return lever.
- Load the coin tubes on the coin changer located on the back side of the front door of the machine. It is very important to fill the 25¢, 10¢ and 5¢ tubes for proper changer payback.

NOTE: The maximum amount of change a Coinco 9302LF changer will hold is \$38.60; \$22.50 in quarters, \$12.00 in dimes and \$3.40 in nickels. The maximum amount of change that a Mars TRC-6010XV will hold is \$29.95; \$16.75 in quarters, \$9.80 in dimes and \$3.40 in nickels.

- Place the price stickers on the trays to the right of the selection stickers and set the prices of the products (See price setting).
- Operate each dispenser, using coins. Operation should be smooth.
- Load the machine with product (See section on product loading).
- Check to make sure that all Vend Options are to the desired setting.

PRODUCT LOADING

Helix Tray Dispenser

There are several helix openings available with Lektro-vend equipment. To insure proper operation and maximum capacity, the product size should closely match the opening between the windings of the helix. The product should fit between the winding of the helix so as not to be tight and should fill most of the opening. If you can lift up on the product in the helix and the helix lifts up with the product, it is too tight and a larger opening needs to be used.

The helix sizes available are listed below

CANDY HELIX

14CT
18CT
22CT
27CT

PRODUCT THICKNESS

1 1/2" large product
1 3/16" medium product
1" standard product
13/16" thin product

PASTRY HELIX (DUAL HELIX)

14CT
18CT
22CT
27CT

PRODUCT THICKNESS

1 1/2" large product
1 3/16" medium product
1" standard product
13/16" thin product

SPECIAL PRODUCT LOADING

NARROW PRODUCT LOADING

In order to keep narrow products positioned properly the use of one of the spacer rails may be required. For additional rails order part no. 099-5107.

To install the spacer rail, press on to the tray divider as shown in Figure 2 below.

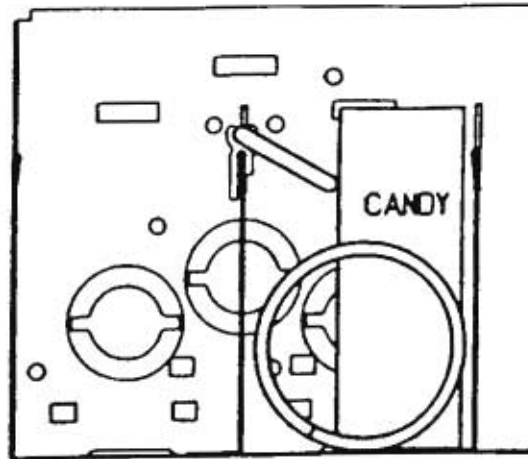

FIGURE 2

(OPTIONAL) GUM AND MINT TRAY LOADING SLIDE OUT DRAWER STYLE

The four select gum and mint dispenser is available in kit form or can be factory installed in a new machine. Each selection will hold up to 15 packs of gum or roll candy up to 4 inches in length. There is a small metal tab that can be installed to allow you to dispense small diameter rolls or anti-acid tablets or similar size products.

All machines are prewired from the factory so you can install the gum and mint kit at a later date. The harness for the gum and mint assembly is plugged into the motor distribution board (same board the trays are plugged into).

LOADING INSTRUCTIONS

Release the tray by pushing on the tab located on the right side of the tray and pulling the tray out to the stop. To load, push the cover toward the rear of the machine. The two wide product selections are fitted with width adapters, installed for dispensing longer products up to 4 inches in length. Place the packs of gum or mints on their side and stack towards the back of the gum and mint tray. Upon filling each selection, slide the tray cover forward back into place. Then slide the tray back into the machine until latched into position.

PRODUCT LOADING

To load a tray, lift up on the tray front. Pulling the tray front up and out, pull the tray out until it comes to the tray stop., then let it tilt down into the loading position.

At this point, check that each helix is in its proper position. The figure below shows the proper position.

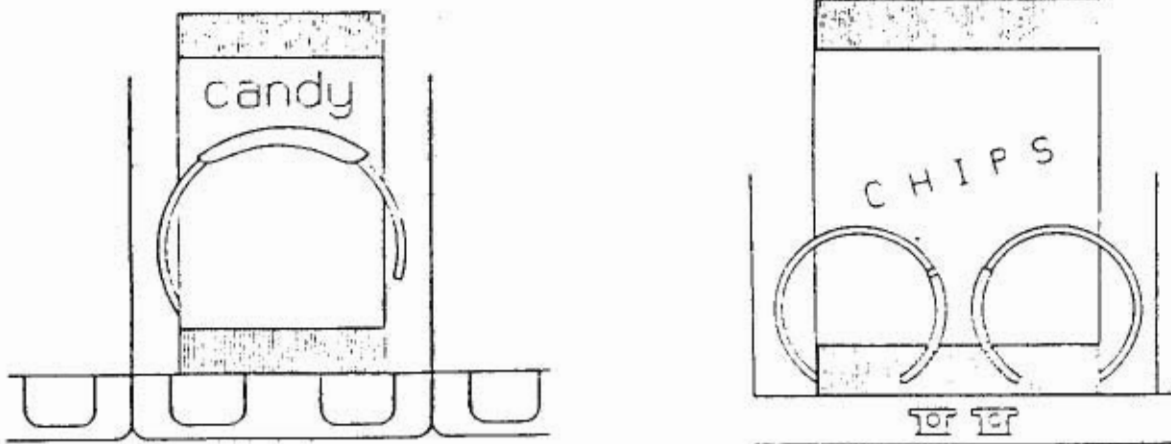

Starting at the front of the tray, insert a product between each winding of the spiral so that the name of the product is displayed forward. Be sure to place the product all the way to the bottom of the tray and tilt free end at the top backwards. Fill from front to back and be sure not to miss any positions. Check to make sure that the product is not too tight for the spiral size being used. This may be done by lifting the product at the top. If the spiral is lifted off the tray with the product, then that product is too tight for the spiral size. After filling the tray, lift the front of the tray, push it back in until the tray hits the stop.

PRIMARY CABINET COMPONENT INFORMATION

HIGH VOLTAGE POWER SUPPLY

The high voltage power supply is located in the bottom of the machine on the left hand side. Inside of the power box are the step down transformer, ballast for the light, and RFI filter. The starter for the fluorescent lights is located on the top of the power supply box. There are two (2) circuit breakers located on the front of the power box.

STORAGE COMPARTMENT

The storage compartment is below the product display area and is accessed by opening the front door. Additional products may be stored in this area. Be sure to leave room for the delivery compartment when using the storage area.

TRAY ARRANGEMENT

The tray arrangement in the VS-99 series Model B or C can be changed. Either a candy or snack tray can be used in positions 2 through 6. The tray in position 1 (top tray in machine) can not be switched with any other tray in machine or it will fall out. Be sure that after you plug the trays in that you power the machine up and go into the service mode. Then press selection button #3 and the digital display will show CONFIGURED when it has been completed. This will put the selections into the motor configuration.

TRAY REMOVAL

To remove a tray from the machine, start by disconnecting the tray harness (notice where harness is plugged in) and pull harness back over the top of the tray. Now pull the tray forward until it comes to the stop and lift up tray until it is at approximately a 45 degree angle with the floor. While holding the tray front with one hand place the other hand near the back of the tray on the bottom and lift up on the tray. Remove the tray from the machine and place the tray on a work surface. To install the tray reverse the process by holding the front of the tray at a 45 degree angle with the floor and sliding tray back into machine. Then install the tray harness. Go into the service mode and press selection button #3. Control board will show CONFIGURED when completed.

THEORY OF OPERATION

When inserting coins and the highest price set in the machine is reached, no additional coins will be accepted. When inserting bills and the highest vend price set in the machine is reached the validator will not accept any additional bills and the changer will not accept any coins.

By pressing a selection letter and number, the control board will compare the price of that selection with the credit accumulated and if there is enough a vend motor will be energized. When the vend is completed the control board will then determine if any change is due and dispense the correct change from the changer.

Should a vend motor fail to return to the home position in six(6) seconds the control board will assume that the motor is jammed. The control board will then automatically take the selection out of service (remove it from the machine configuration) and inform the customer to "MAKE AN ALTERNATE SELECTION". A jammed motor does not affect any other selection in the machine. The selection that is jammed will be displayed on the digital display as out of service when the mode button is pressed. The vend motor can be put back into service when the mode button is pressed and the selection has been service vended (free vended) two (2) times.

If the level of coins in the changer is too low the control board will display the message "USE CORRECT CHANGE" on the display and will also shut down the bill acceptance feature (if validator is installed).

When going into the Service Mode the control board will display the following message if there is a problem.

- A. The selection letter and number of a faulty or jammed motor along with an error code. Error 1 or Error 2
Error 1 - Too little motor current
Error 2 - Too much time to complete vend
- B. Error code 3 = Loss of communication with changer.
Changer has malfunctioned
- C. Error code 4 = EEPROM Sum check error. Display will scroll PLEASE CALL SERVICE (6 seconds).

NOTE: Error 4 = Prices have been inadvertently altered and all prices have automatically been set to maximum by the control board. To clear these prices, reset pricing as desired.

If a bill validator is being utilized the machine can be programmed to Forced Vend or a Non-Forced Vend System. When the Forced Vend option is "ON" the customer must make a selection when the bill is accepted. Thus, the customer cannot use the machine as a change maker.

CAUTION: When removing the control board extreme care should be taken to avoid introducing static electricity into or onto the board. Under no circumstances should the board be placed on anything made of metal. To remove the control board simply disconnect power to the control board, remove the control board cover, unplug the harness and remove the screws mounting the control board to the door.

63

ELECTRICAL SERVICE SECTION

MODES OF OPERATION

The system will operate in one of two modes, sales or service. On power up (after completing configuration), the machine is in the sales mode. Service mode may be selected by pressing the mode button mounted on the control board. The system will return to the sales mode if the mode button is pressed again or after 25 seconds of no service activity.

SALES MODE

In the sales mode, the control board will control the dispensing of products according to customer credit and selection inputs. The control board will communicate with the coin mechanism and dollar bill validator (if installed); so, as credit is entered it will be shown on the scrolling display. If there is inadequate change available, the coin mechanism will indicate that an exact change situation exists and the control board will show on the scrolling display "PLEASE INSERT EXACT MONEY".

When a customer makes a selection on the key pad, A thru G and (within 5 seconds) numbers 0 thru 9, the accumulated credit will be compared to the price set for this selection and if credit is equal to or exceeds the set price, the corresponding motor will be energized. If the vend is successful the price will be deducted from the credit value and the change returned.

The vend will be considered unsuccessful if the motor does not receive sufficient current or fails to reach the home position within six (6) seconds. The vend will not be attempted if the motor has already been detected as failed or if the selection made is not in the configuration of the machine. In any case, credit will not be deducted and the "MAKE ALTERNATE SELECTION", message will be on the scrolling display until a new selection is made.

If there is insufficient credit for the selection made, the selection made and the price of that selection will be displayed for five (5) seconds, followed by the message "PLEASE INSERT MORE MONEY". This message will be displayed until either enough credit is added and the selection made again or a lower price selection is made. The correct selection and the selection price will be displayed during the vend.

If power should fail during a vend, the credit will be lost and the selected motor will not be re-energized when power returns, thus the next vend of this motor may be shorter than normal.

SERVICE MODE

The service mode can be entered by pressing the "MODE BUTTON" located on the control board just above the 24 volt red power indicator light. By using the numbers and letters on the alphanumeric key pad, the operator can program and review the features of the control board. Upon pressing the "MODE BUTTON" the display will sequence through (1.5 seconds each). The alphanumeric selections and codes of any motors which have failed will appear on the right, telling the operator the reason for the failure. Pressing and holding the #13 button will abort this sequence display.

ERROR CODES

1. Error 1 = Too little motor current
2. Error 2 = Too much time to complete the vend (6 seconds)
3. Error 3 = The control board has lost communications with the changer (changer has malfunctioned).
4. Error 4 = EEPROM sum check error. Display will scroll "PLEASE CALL SERVICE".

NOTE: Error 4 = prices have been inadvertently altered and all prices have automatically been set to maximum by the control board. To clear these prices, reset pricing as desired.

ELECTRONIC SPECIFICATIONS

1. Prices can be set to a maximum of \$99.95.
2. The control board will interface with the following coin mechanisms:
 - A. Coinco 9302LF 15 pin
 - B. Mars TRC-6010XV 15 pin
3. The international control board will interface with the following validators and will accept \$1 bills, \$2 bills, \$5 bills, \$10 bills and \$20 bills.
 - A. Coinco BA32SA*
*Option switches should be set as follows, switches 3 and 8 should be "on".
 - B. Maka NB-1B 24 volt
 - C. Mars VFM1-L2-U2C
Mars VFM3-L2-U2C*
*Option switches should be set as follows, switch 5 should be in the "on" position.

CAUTION: When removing the control board extreme care should be taken to avoid introducing static electricity into or onto the board. Under no circumstances should the board be placed on anything made of metal. To remove the control board simply disconnect power to the control board, remove the control board cover, unplug the harness and remove the screws mounting the control board to the door.

DETAILED OPERATION OF CONTROL BOARD

At the time of delivery the control board will be set as follows:

1. All vend options will be off.
2. The cash accountability will be set to \$00,000.00
NOTE: Due to factory testing the total will not be exactly \$00,000.00
3. All of the prices will be set to \$00.50
4. The total number of vends non-resettable will be 000000.
NOTE: Due to factory testing the total will not be exactly 000000.
5. The time and date will be blank with the clock turned off.
6. The timed shut down intervals will be blank.
7. The promotional rows will be blank.

MODES OF OPERATION

The system will operate in one or two modes, sales or service. On power up (after completing configuration), the machine is in the sales mode. Service mode may be selected by pressing the mode button mounted on the control board. The system will return to the sales mode if the mode button is pressed again or after 25 seconds of no service mode activity.

ERROR CODES

1. Error 1 = Too little motor current
2. Error 2 = Too much time to complete the vend (6 seconds)
3. Error 3 = The control board has lost communications with the changer (changer has malfunctioned).
4. Error 4 = EEPROM sum check error. Display will scroll "PLEASE CALL SERVICE".

NOTE: Error 4 = Prices have been inadvertently altered and all prices have automatically been set to maximum by the control board. To clear these prices, reset pricing as desired.

1. COIN DISPENSING

To dispense nickels, dimes or quarters from the changer, press service mode button. Now press selection button #1, then press selection button "A" for nickels to be dispensed, "B" for dimes to be dispensed and "C" for quarters to be dispensed.

2. MOTOR COUNT

While in the service mode, press selection button #2 to display the total number of functioning motors. On the display the message "MOTORS" and the total number found in the machine will appear.

3. MOTOR REMOVAL (CONFIGURATION)

To remove a motor from the configuration while in the service mode, press selection button #3. The control board will reconfigure to the currently functioning motors. The display will show "CONFIGURED" when completed.

4. ACCOUNTABILITY SYSTEM

1. CASH ACCOUNTABILITY

While in the service mode press selection button #4. The display will show "ACCOUNTING" then press one of the following letters

A = Total cash accountability, the total value of all paid sales which will rollover after \$99,999.95.

B = Total bill validator accountability (if bill validator installed), the total number of bills taken in which will rollover after 99,999.

Note: This feature can not be reset.

To exit this mode, press selection button #13.

2. TOTAL NUMBER OF PRODUCTS VENDED

While in the service mode press selection button #4. The display will show "ACCOUNTING". Press selection button "C" to display the total number of products vended from this machine, which will rollover after 79,999,920. This functions is non-resettable.

3. TOTAL NUMBER OF PRODUCTS VENDED (RESETTABLE FUNCTION)

While in the service mode press selection button #4. The display will show "ACCOUNTING". Press selection button "D" to display the total number of products vended since the last reset, or will rollover after 79,999,920.

4. RESET ALL RESETTABLE FUNCTIONS AT ONCE

While in the service mode press selection button #4. The display will show "ACCOUNTING". Press selection button "E". The display will show "RESET". To reset all resettable functions only, press selection button "F". All functions will reset to "0".

5. DOWNLOAD DEX/UCS

While in the service mode press selection button #4. The display will show "DEX/UCS" and the control board will download the information to a hand held unit. Upon completion of the download of the items, it will be necessary for the operator to then reset all of the resettable functions. The download of the control board does not automatically reset these items to 0. They must be manually reset. See step 4 above.

5. PRICE SETTING

A. Price setting of the Entire Machine

To set the price of the entire machine while in the service mode, press selection button #5. The control board will display "SELECTION", then you may press any selection letter and number. The control board will display the selection letter and number and the price. Using the numbers on the key pad, press the most significant digit first, then the less significant digits. Example: \$00.90. Press selection button #9, then press selection button #0. To save this price for the entire machine press selection button #12. To cancel an unwanted price before the fourth number is entered, press selection button #13.

B. Price Setting by Row

To set the price of an entire row of selections while in the service mode press selection button #5. The control board will display "SELECTION". Then enter a selection letter and number from the row you want to set the prices on. The display will show the letter, number and current price. Using the numbers on the key pad, press the most significant number of the price first, follow by the less significant numbers. Example : \$00.90. Press selection button #9 then press selection button #0. The digital display should read \$00.90. In order to save this and set the entire row to this price, press selection button #11. To set the next row, press the #5 selection button, then enter the letter and number from the next row you want to set the prices on and repeat the price setting procedure. To cancel an unwanted price before the fourth number is entered press selection button #13.

C. Individual Price Setting

To set a single price on one item, while in the service mode, press selection button #5. The control board will display "SELECTION". Press the letter and number of the selection you wish to change. The selection letter and number will be displayed along with the current price. Using the numbers on the key pad, press the most significant digit first, then the less significant digits. Example: \$00.85. Press selection button #8, then press selection button #5. The digital display should read \$00.85. To save this price, press selection button #10. To set another single price, press selection button #5 and repeat the above sequence. To cancel an unwanted price before the fourth digit is entered, press button #13.

NOTE: When the price is set to \$00.00, this is allowed and is a service vend (free vend). The machine can then be used as a display or show machine.

6. SERVICE VEND

A. Service Vend by Individual Selection

To test vend a vend motor, while in the service mode, press selection button #6. The control board will display "SELECTION". Enter the desired selection letter, followed by the selection number. This will be displayed with the selection price, while a vend of the motor is attempted. If the vend is successful, the display will blank. If the vend is not successful, the control board will beep three times before blanking.

B. Service Vend by Row

To service vend an entire row of selections, while in the service mode, press selection button #7. The control board will display "SELECTION". Enter the letter of the desired row. The control board will display the selection letter, number and the price while the vend is attempted, starting with the highest number selection in that row. If the vend is successful, the control board will continue with the next selection. If the end is not successful, the control board will beep three times and continue with the next motor. This cycle will repeat until vends on all motors in that row have been attempted, then the display will blank.

C. Service Vend of Entire Machine

To service vend the entire machine of selections one time, while in the service mode, press selection button #8. The control board will display the selection letter and number and price as the corresponding vend is attempted. If the vend is successful, the control board will continue on with the next motor. If the vend is not successful, the control board will beep three times and continue with the next motor. This cycle will repeat until vends on all selections in the machine have been attempted, then the display will blank.

To stop the vending of the selections press selection button #13 and hold in until the current vend is completed.

7. POINT OF SALES MESSAGE PROGRAMMING

The machine comes preset from the factory with the message "ENJOY ONE OF OUR FINE SNACK PRODUCTS".

If you wish to change the Point of Sales message, press the service mode button on the control board, then press selection button #9. The control board will display "MESSAGE". Using the keypad overlay (provided in the large manila envelope) and following the keypad definitions, enter the new message. Menu 1 (blue characters) is the default menu. After each key entry, from either menu, the keypad will return to Menu 1. To use Menu 2 (red characters), SHIFT (NEXT MENU) key must be pressed prior to pressing a Menu 2 key. If you enter the wrong letter, press BACK SPACE to remove that letter from message. Put two (2) spaces at the end of the message to prevent the message from running together. To save the message press "SHIFT" then press "ENTER" from within Menu 2.

Note: The maximum number of characters you can enter to form a message is 53 plus two spaces at the end of the message. A space between two words is one character.

MENU 1 (blue)				MENU 2 (red)	
A	G	M	S	Y	4
B	H	N	T	Z	5
C	I	O	U	O	6
D	J	P	V	1	7
E	K	Q	W	2	8
F	L	R	X	3	9
SPACE	SHIFT	BACK	*	ENTER	\$
	(NEXT MENU)	SPACE			

EXAMPLE: ENJOY OUR SNACKS". Press selection button #9, "MESSAGE" appears on display. Using the overlay press the letter E, letter N, letter J, letter O, press SHIFT, press Y, press SPACE, press O, press U, press R, press SPACE, press SHIFT, press S, press N, press A, press C, press K, press shift, press S, press SPACE, press SHIFT, press ENTER. The message should start scrolling when you press the mode button.

8. LANGUAGE SELECTION

To select the message language, while in the service mode, press selection button #10. The scrolling display will display "LANGUAGE". Press the letter of the language you wish to program (See list below). The language selected will be displayed, or you can program your own message using button #11.

Press button #10 + button A = Italian
 Press button #10 + button B = Dutch
 Press button #10 + button C = Spanish
 Press button #10 + button D = Danish
 Press button #10 + button E = English
 Press button #10 + button F = French
 Press button #10 + button G = German
 Press button #10 + button 11 = ADD MESSAGE

Note: Control board will only display translation for "Please Insert More Money", "Exact Change Only", "Please Make Alternate Selection", and "Please Call Service". It will not translate the Point of Sales Message.

Under selection button #11, the control board will display "MESSAGE 1". Using the same overlay for the Point of Sale Programming, enter the first message "PLEASE INSERT EXACT MONEY" in the language desired then press SHIFT, then press ENTER. Next enter PLEASE INSERT MORE MONEY in the language you desire, then press SHIFT, then press ENTER. Enter MAKE ALTERNATE SELECTION in the desired language then press SHIFT, then press ENTER. Now enter the message PLEASE CALL SERVICE in the language desired. Then press SHIFT, then press ENTER. The maximum length of messages one and two are thirty (30) characters each. The maximum length of messages three and four is twenty five (25) characters.

9. VEND OPTIONS

To enable or disable the vend options, while in the service mode, press selection button #11. The control board will display "OPTIONS". Press one of the appropriate letters listed below. After the letter has been pressed, the current status of the option will be displayed. The option may be changed by following the instructions pertaining to that option.

A. Bill Escrow (if it is a feature of the bill validator installed).

This option will allow the last bill accepted to be escrowed, provided the bill validator is capable of such a feature. To access this, while in the service mode, press selection button #11, then press selection button "A". The feature will be displayed with its present status. To change the status press selection button "A" again.

B. Forced Vend

This option (when turned "ON") will force the customer to complete a purchase once they have deposited money of any form. If a vend is attempted and the motor fails during this vend, the customer will be allowed to escrow the credit, regardless of the force vend status. To access this option, press selection button #11 then press selection button "B". The feature will then be displayed with its present status. To change the status press selection button "B" again.

C. Maximum Change Return

This option will limit the amount of change returned to the customer. The change above the limit will be given as credit toward another purchase, i.e. a multi-vend situation. To access this option press selection button #11, then press selection button "C". The status of the option will be shown. If the option is "OFF", press selection button "C" again to turn it "ON". After enabling the option, wait for one second and the current limit will be displayed. This limit may be changed by pressing the most significant digit first and then the less significant digits. Press selection button #11 to lock in this limit.

NOTE: The only time that the control board will display the amount of the limit is when the feature is first turned on. In order to check the amount set, turn the feature "OFF" and "ON".

To exit this mode, press the service mode button.

D. TO SET CONTROL BOARD TIME AND DATE

This option will allow the control board to set the time and date for timed operations. Should you lose power to the machine, a back-up battery will maintain the correct time and date.

To access this option press selection button #11, then press selection button "D". The current status of the option will be displayed. To change the option, release button "D" and press it again. The selection will then change. When the option is turned "on" the current time of day will be displayed in a 24 hour format (1 PM would be 1300) as TIME hh.mm.. A new time may be entered by pressing the selection buttons on the front of the machine and will be displayed as they are pressed. The most significant digit followed by lesser significant. Example 1325 would be entered by pressing selection button #1, selection button #3 selection button #2, then selection button #5. To save this entry, press selection button #10. The current month will then be displayed in a numeric format as "MONTH 03" (03 = March). A new month may be entered by pressing the selection buttons. As each button is pressed it will be shown on the display. The most significant digit should be entered followed by the lesser significant digit. To save this entry press selection button #10. The current day of the week will be displayed in a numeric format as DAY dd. The numbers start with Sunday as 01 on through to Saturday as 07. A new day may be entered by pressing the selection number keys which will be displayed as they are entered. To save this entry press selection button #10. The current year will now be display as YEAR yy in a numeric format. A year may be entered by pressing the selection number keys which will be displayed as they are entered. The most significant digit should be entered first followed by the less significant. To save this entry press selection button #10. To cancel unwanted setting before saving, press selection button #13.

E. SETTING TIME SHUT DOWN OF MACHINE

This option will allow the control board to shut down the entire machine four times during a 24 hour period. During these time intervals the point of sales message will read "VENDING OPERATION TO RESUME AT hh.mm."

To avoid confusion with this option when the time is set to start that is the time the machine will shut down. When the time is set to stop that is the time the machine is turned on.

To set this option after going into the service mode, press selection button #11, then press selection button "E". The current on/off setting will be displayed as "TIME XXXX". To change the current on/off setting press selection button "E" again. With the setting to "ON" position, to program the start, stop and active days for the time to occur, wait one second and the display will continue to "1STRT hh.mm.". A new start time (time the machine will shut down) for this interval may be entered by pressing the selection button numbers, which will be displayed as the number buttons are pressed. The most significant digit is entered first followed by the lesser significant digits. Only the first four numbers will be used. To save this entry press selection button #10. The display will continue to "1STOPP hh.mm." A new stop time (time machine will vend again). A new stop time for this interval may now be entered by pressing the selection button numbers, which will be displayed as the number buttons are pressed. The most significant digit should be entered first followed by the lesser digits. Only the first 4 digits will be used and can be saved by pressing selection button #10. The display will continue to the daily on/off status (the days you want this time to occur) shown as 1DY xxxxxx. The x's will be either a "0" for off or a "1" for on. The first x will show the status of Sunday, the next x for Monday, and so on, until Saturday. The daily status may be changed by pressing the 0 or 1 keys. Each digit will be rotated in from the left side. To save this entry press selection button #10. The display will go to the next time set up as 2STRT hh.mm. Repeat the procedure above for this set up and the two additional ones if required. When all four intervals have been programmed the control board will return to the service mode. To avoid confusion, again the start time is when the machine is going to be turned off, and the stop time is going to be when the machine is turned on.

F. ONE FREE PRODUCT SETTING

This option will allow a free product to be given to the customer at a preprogrammed interval. Setting this interval to "1" provides a free vend at every transaction "0" disables the option and the maximum valid interval is 255.

To access this option press selection button #11, then press selection button F. The current interval will be displayed as "FREE XXX". A new interval may be entered by pressing the selection button numbers, which will be displayed as they are entered. The most significant digit is entered first followed by the lesser significant digits. To save this entry press selection button #10.

To cancel an unwanted setting before saving, press selection button #13.

G. PROMOTIONAL VEND SETTING

This option will allow a promotional product to be given to a customer for free in response to the purchase of another product. When enabled, purchasing selection "0" from one of the two possible promotional rows will result in both the selection chosen and a promotional item of that row to vend sequentially.

To access this option press selection button #11, then press selection button "G". This will toggle the on/off state. To program the promotional rows, after enabling the option as above, wait 1 second and the display will continue to "ROWS aa". New rows may be entered by pressing the alphabetic selection buttons of the desired row. The first entry will affect the center character and the second will affect the right most character. Pressing selection button #12 before #10 will clear both entries. Press selection button #10 to save the entry. If the E row has been selected then when selection E-1 is chosen then that selection will vend then selection E-0 will vend giving a free item.

To cancel an unwanted setting before saving, press selection button #13.

CLEANING AND MAINTENANCE

PAINTED SURFACES

All painted surfaces and the vinyl covered product delivery door can be cleaned with a clean cloth and any common brand of household detergent. Do not use harsh abrasive materials on these surfaces, they will scratch the paint or vinyl.

GLASS ITEMS

The glass service door may be cleaned with any commercial window cleaner.

TRAY SURFACES

Quite often wax and oil will build up on the tray surface area. To remove this, use a wax and paraffin remover solution.

POLYVEND SHIPPING POLICY

The following information is to assist you in assuring safe delivery of your merchandise and in expediting of freight damage claims.

Our terms of sale are F.O.B. our factory. The responsibility for damage in transit is the carrier's whether it be visible or concealed damage. We have taken every precaution to ensure safe arrival of this equipment, but our responsibility ceases the moment the shipment is turned over to the carrier.

Acceptance of this shipment by the carrier is an acknowledgment that the equipment was delivered to them in good condition and properly packed. The carrier who delivers this merchandise to your door is responsible for its safe delivery.

PROCEDURE FOR VISIBLE DAMAGE

1. IT IS VERY IMPORTANT TO INSPECT ALL FREIGHT DELIVERIES, WHETHER MACHINES OR PARTS, IMMEDIATELY. If there is any visible damage you have the right to either refuse the merchandise or accept the damaged shipment. If you accept it, make certain that you have the delivery personnel note the nature and extent of damage on the freight bill.
2. After you determine the extent and cost of the damage, notify the delivering carrier's office by phone and confirm with a written notice within 15 days requesting an inspection of the damaged merchandise. Keep a copy of the inspection request for claim purposes. Do not destroy the packing material until shipment is inspected and claim is settled.
3. When the inspector arrives, ask for a claim form. In filing a claim, you may make a cash settlement with the carrier for the full invoice price of the merchandise or contact Polyvend Inc. at 1-800-710-8363 and make arrangements to have merchandise returned for repair and file a claim for repair charges. Do not return "DEADHEAD". Do not claim more than the cash price of the machine, plus freight.

PROCEDURE FOR CONCEALED DAMAGE

1. If there is no visible damage, YOU MUST OPEN THE SHIPMENT WITHIN 15 DAYS AND INSPECT FOR CONCEALED DAMAGE. If there is concealed damage, notify the delivering carrier by phone immediately asking for an inspection. Confirm the request in writing and keep a copy for claim purposes. If you fail to notify the carrier within 15 days of delivery by telephone and in writing, the freight company is no longer liable for damage and will probably refuse your claim. Do not destroy packing material until shipment is inspected and claim is settled.
2. After inspection by the carrier, file a claim for damages at once. On concealed damage, unless it can be proven that the carrier is responsible for the damage, they will probably want to settle on a compromise basis. Therefore, the faster you inspect your delivery and notify the carrier, the better the chances for full settlement. If the claim is disallowed, check on the possibility of a compromise.

PROCEDURES FOR SHORTAGES

1. If the shipment delivered to you is not in accordance with the quantity of cartons shown on your receipt, do not accept it until shortages are noted on the Freight Bill or Bill of Lading and signed by the truck driver. Failure to do this releases the carrier from any responsibility.

2. If the shorted item is not delivered within a reasonable time, file a claim with the delivering carrier for the invoice or cash price of that item.

NOTE: Claims for loss or damage will NOT BE DEDUCTED FROM YOUR INVOICE while you wait adjustment of such claims.

TROUBLESHOOTING CHART

CAUTION

DISCONNECT POWER TO MACHINE BEFORE WORKING ON, CHANGING, DISCONNECTING OR CONNECTING ANY ELECTRICAL COMPONENTS BY PULLING OUT DOOR SWITCH, TURNING OFF THE POWER TO THE MACHINE AT THE WALL OUTLET OR UNPLUGGING THE MACHINE.

SYMPTOM	PROBABLE CAUSE	CORRECTIVE ACTION
<p>1. All coins deposited are rejected.</p> <p>In service mode, shows error 3.</p>	<p>Machine not level</p> <p>Defective coin mechanism</p> <p>Display blank, power indicator light not illuminated.</p>	<p>Level cabinet</p> <p>Replace coin mechanism</p> <p>Check circuit breaker, power at wall outlet and transformer.</p>
<p>2. Selection motor fails to run.</p> <p>In service mode, display shows selection and error 1.</p>	<p>Insufficient credit established.</p> <p>Defective motor assembly.</p> <p>Defective control board.</p>	<p>Check to see that selection price is same as deposited amount. Note message on display.</p> <p>Service vend bad motor. Replace if defective. See note 2 page 25.</p> <p>Replace control board. See note 1 below.</p>
<p>3. All selection motors do not run.</p> <p>Test or service vend motors do not run power indicator light illuminated.</p>	<p>Defective control board.</p> <p>Wire connection broken.</p>	<p>Replace control board. See note 1</p> <p>Trace wire harness. For color code see note 3 page 25.</p>
<p>4. Selection motor does not complete cycle. In service mode display shows error 2.</p>	<p>Defective full cycle switch or or defective motor.</p> <p>Defective components on motor PC board assembly.</p> <p>Defective control board.</p>	<p>Replace motor assembly. See note 2 page 25.</p> <p>Replace motor assembly. See note 2 page 25.</p> <p>Replace control board. See note 1 below.</p>

NOTE 1: When you replace the control board always disconnect power to the equipment. After the control board is installed, re-apply power, go into the service mode and press button #2, then press button #3. You have now aligned the control board with the motors.

Caution: When removing the control board, extreme care should be taken to avoid introducing static electricity onto the board. Under no circumstances should the control board be placed on anything made of metal.

SYMPTOM	PROBABLE CAUSE	CORRECTIVE ACTION
5. Selection motor continuously cycles shows error 2 in service mode	Defective full cycle switch Defective control board	Replace motor assembly. Replace control board. See note 1 pg. 23
6. Two motors run simultaneously	Defective control board Defective motor assembly Defective tray distribution board Shorted harness or wire connector	Replace control board. See note 1 page 23. Replace motor assembly Replace tray distribution board Repair or replace
7. Unable to make a selection. Either no selection number on display or wrong number.	Selector pad bad. Attempt to change price of selection. Unable to change price.	Replace selector pad.
8. Insert dollar bill, shows credit, no product dispensed	Defective control board.	Replace control board. See note 1 page 23.
9. Dollar bill validator will into accept dollar bills. Will not accept dollar bills.	Bill scanner dirty. Not enough coins in coin changer. Defective coin changer. Defective bill validator.	Clean scanner area. Fill changer with coins. Replace changer. Replace bill validator.
10. Insert dollar bill, does not show credit, or make a selection.	Defective bill validator.	Replace bill validator.
11. Display is blank, power indicator light not on. Fluorescent light on.	Circuit breaker tripped.	Check circuit breaker reset if tripped.
12. Display is blank, power indicator light on.	Defective control board.	Replace control board. See note 1 page 23.

SYMPTOM	PROBABLE CAUSE	CORRECTIVE ACTION
13. Coin mechanism returns nickels and dimes with no product vended.	Defective control board.	Replace defective control board. See note 1 page 23.
In service mode display shows error 3.	Defective changer.	Replace changer.

NOTE 2: When replacing a bad motor, always service vend the new motor to tell the control board that a new motor has been installed.

NOTE 3: The motors in the machine are arranged in a 7 X 10 matrix. This means that all motors have a wire common to all other motors in that row. Example: All motors in horizontal row "A" have a violet wire in common in the main motor harness from the control board. Likewise, all the motors in a vertical column have a wire in common. Example: All motors in column 2 have a white wire in common in the main motor harness from the control board.

The following is the wire color guide for the motor matrix in the main motor harness:

	<u>Wire color</u>
Row "A"	Violet
Row "B"	Gray
Row "C"	Orange
Row "D"	Yellow
Row "E"	Green
Row "F"	White / Brown
Row "G"	White/Blue
Row "H"	Blue

The tray harness uses only the black and white striped wire as the common wire in any row.

Column "1"	White / Green
Column "2"	White
Column "3"	White / Black
Column "4"	Red
Column "5"	Brown
Column "6"	Black
Column "7"	White / Orange
Column "8"	White / Violet
Column "9"	White / Yellow
Column "10"	White / Red

ERROR CODES

1. Error 1 = Too little motor current
2. Error 2 = Too much time to complete the vend (6 seconds).
3. Error 3 = The control board has lost communications with the changer (changer has malfunctioned).
4. Error 4 = EEPROM sum check error. Display scrolls "PLEASE CALL SERVICE".

Note: Error 4 = Prices have been inadvertently altered and all prices have automatically been set to maximum by the control board. To clear these prices, reset prices as desired.

DIAGRAMS AND PARTS LISTS

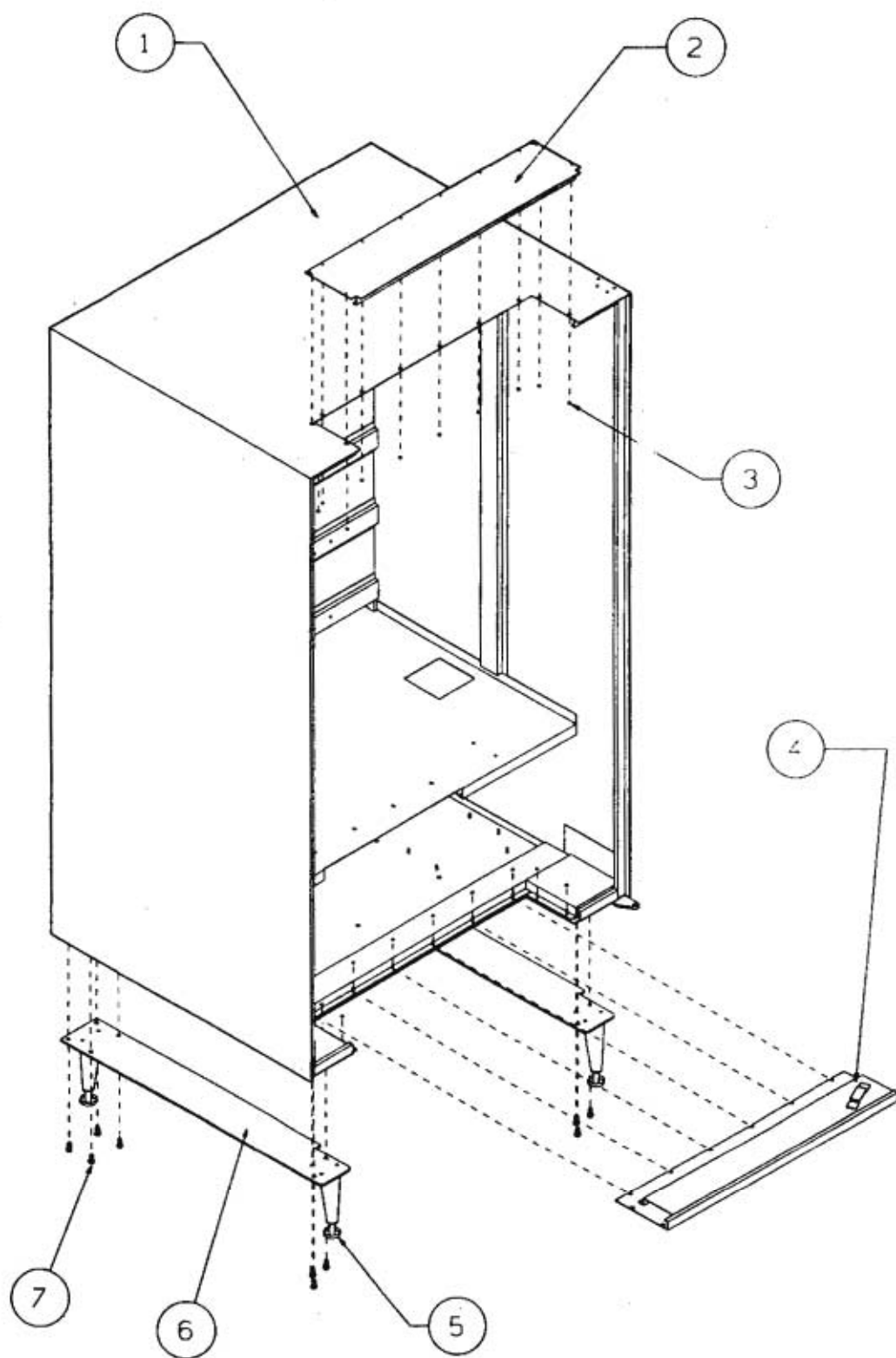

BASIC CABINET ASSEMBLY MODEL B AND C PARTS LIST

ITEM	DESCRIPTION	PART NO.	QTY.
1	CABINET ASSEMBLY B CABINET	099-5538	1
	CABINET ASSEMBLY C CABINET	099-5539	1
2	CABINET "TOP" INSERT ASSEMBLY	099-5164BLK	1
3	HEX NUT/W LOCKWASHER #8-32	20208	20
4	CABINET "BOTTOM" INSERT C CABINET	099-5156BLK	1
	CABINET "BOTTOM" INSERT B CABINET	099-5157BLK	1
5	LEG LEVELER	19765	4
6	CABINET LEG ASSEMBLY	224-5054BLK	2
7	HEX HEAD BOLT 5/16-18 X 5/8	19302	14

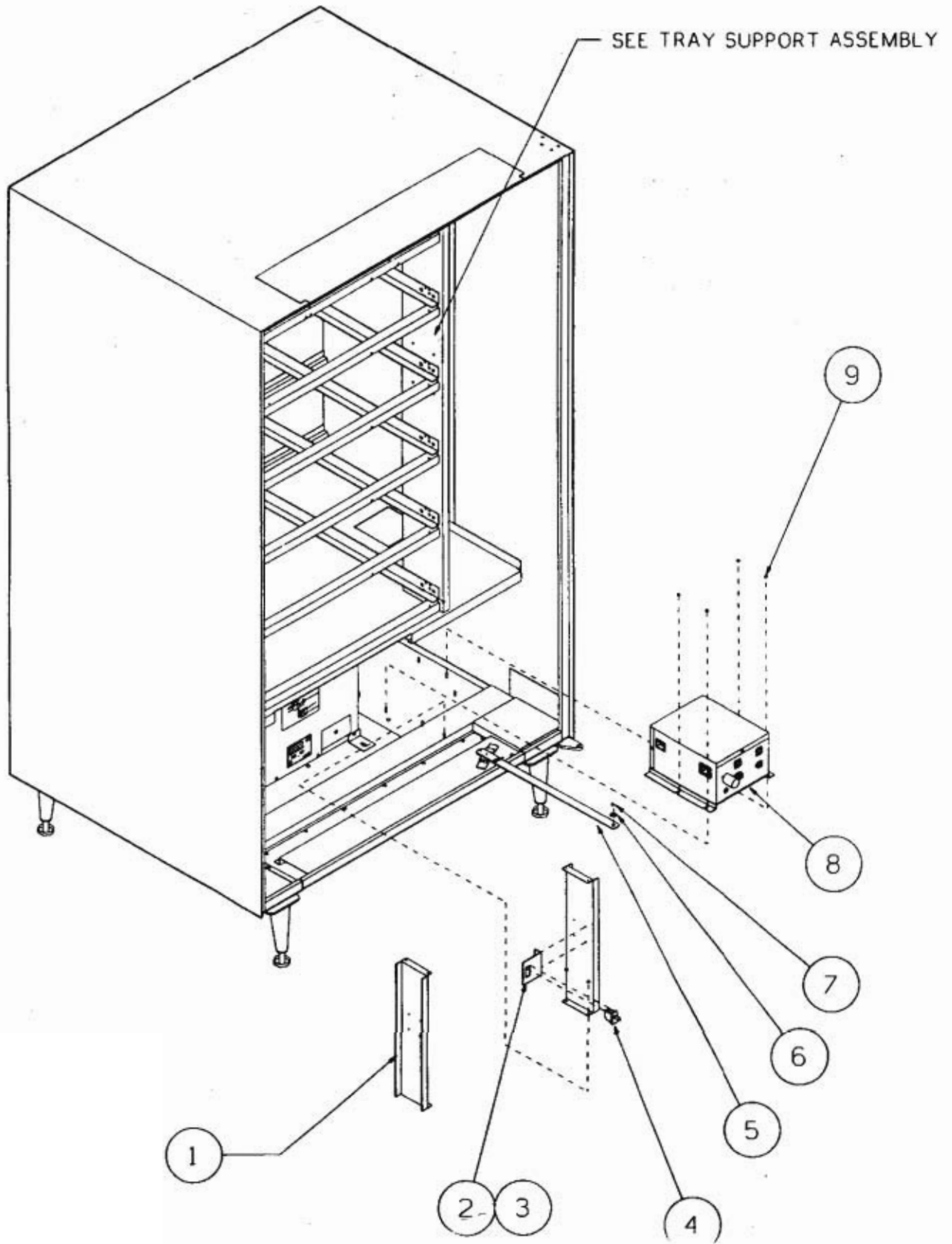

**BASIC CABINET ASSEMBLY BOTTOM AREA
MODEL B AND C
PARTS LIST.**

ITEM	DESCRIPTION	PART NO.	QTY.
1	MAIN SHELF SUPPORT	099-4159	2
2	DOOR SWITCH BRACKET	099-4083	1
3	SCREW #8-32 X 1/4	S42C832-4	2
4	DOOR SWITCH	099-8037	1
5	DOOR STOP ARM ASSEMBLY	210-5076	1
6	WASHER 5/16	W10C312	1
7	RETAINING RING	R10K312	1
8	POWER BOX ASSEMBLY B/C MODEL	099-5546	1
9	HEX NUT W/LOCKWASHER #8-32	20208	4

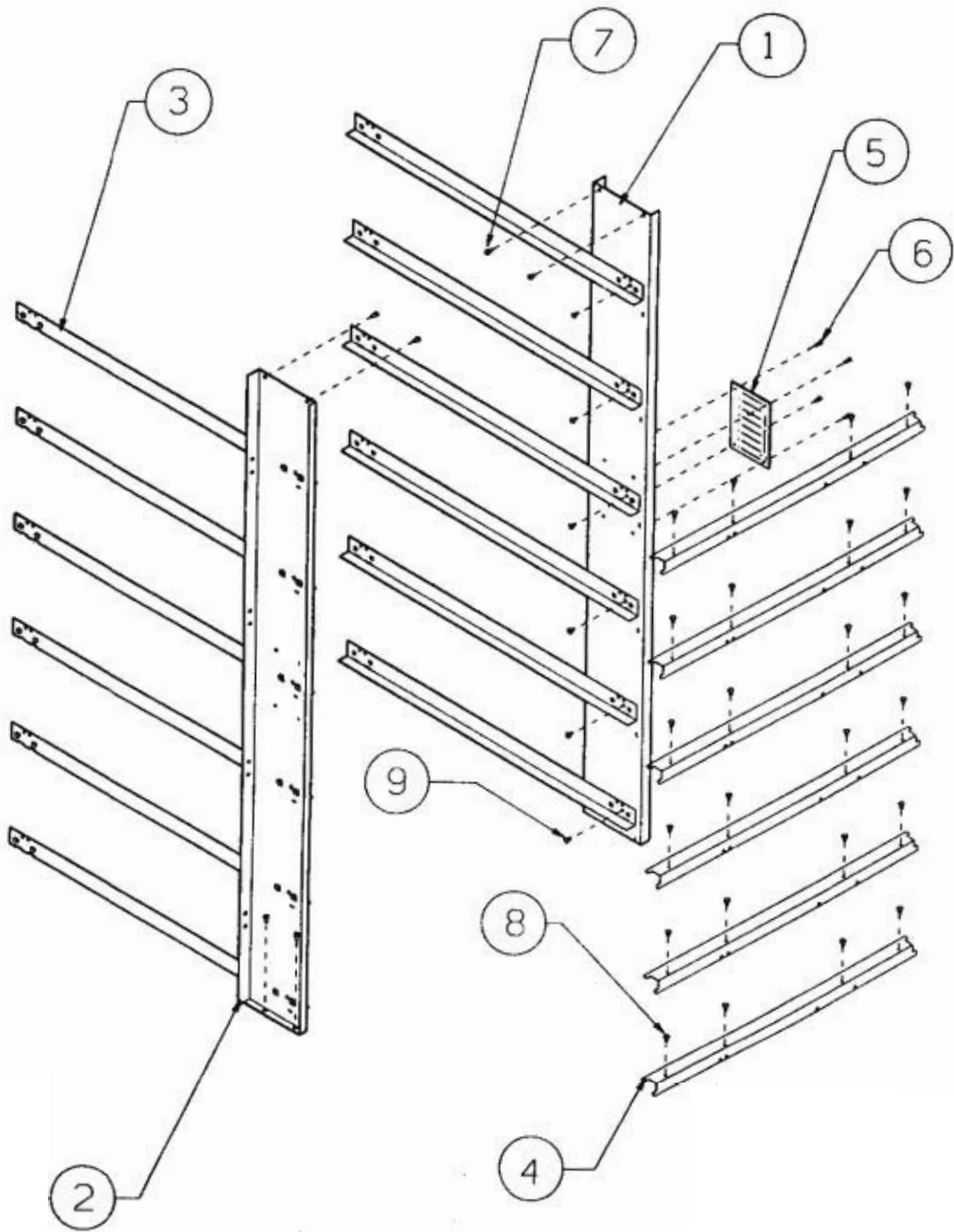

**TRAY SUPPORT ASSEMBLY
MODEL B AND C
PARTS LIST**

ITEM	DESCRIPTION	PART NO.	QTY.
1	L.H. TRAY SUPPORT	099-4064	1
2	R.H. TRAY SUPPORT	099-4065	1
3	UNIVERSAL TRACK	099-4160	12
4	FRONT TRAY SUPPORT B-MODEL	240-4050	6
	FRONT TRAY SUPPORT C-MODEL	224-4046	6
5	TRAY DISTRIBUTION PC BOARD	2142402	1
6	MACHINE SCREW #6-32 X 3/8"	00302	4
7	SCREW #10-32 X 3/8"	S20C1032-8	4
8	CANOE CLIP .060 ROUNDHEAD	210-8012	18
9	CANOE CLIP .100 ROUNDHEAD	210-8021	12

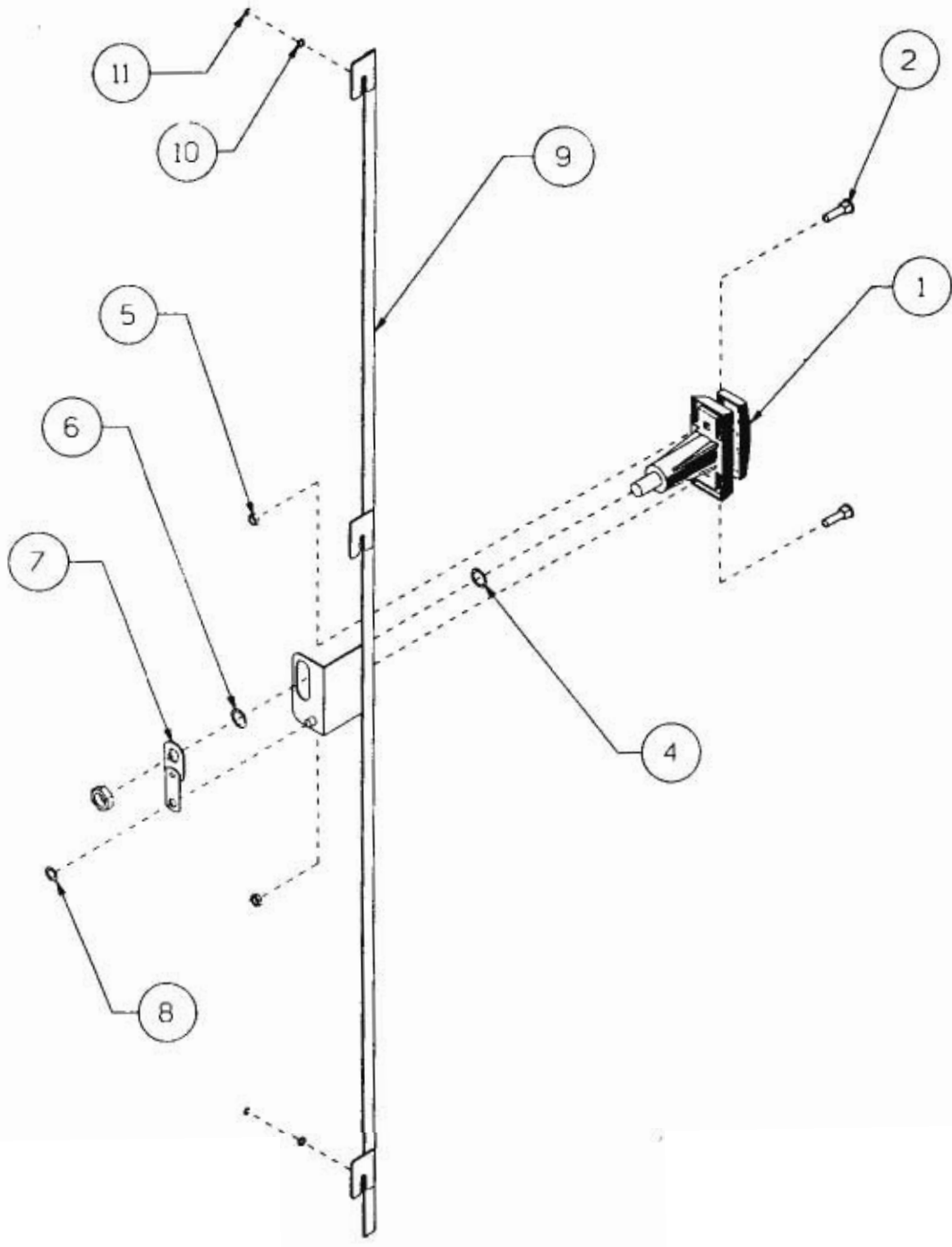

**FRONT DOOR LOCKING ASSEMBLY
MODEL B AND C
PARTS LIST**

ITEM	DESCRIPTION	PART NO.	QTY.
1	LARGE T-HANDLE LOCK ASSEMBLY	170-8003	1
2	CARRIAGE BOLT #10-24 X 3/4"	15249	2
3	NOT REQUIRED		
4	DOUBLE "D" WASHER	170-4089	1
5	HEX NUT W/WASHER #10-24	N20C1024	2
6	SPACER BUSHING	170-6008	1
7	DRIVE CAM AND LEVER ASSEMBLY	170-5028	1
8	RETAINING RING 5/16	R12K312	1
9	LOCKING BAR ASSEMBLY	230-5026	1
10	FLAT WASHER	W10C10	2
11	RETAINING RING 3/16	R10K187	2

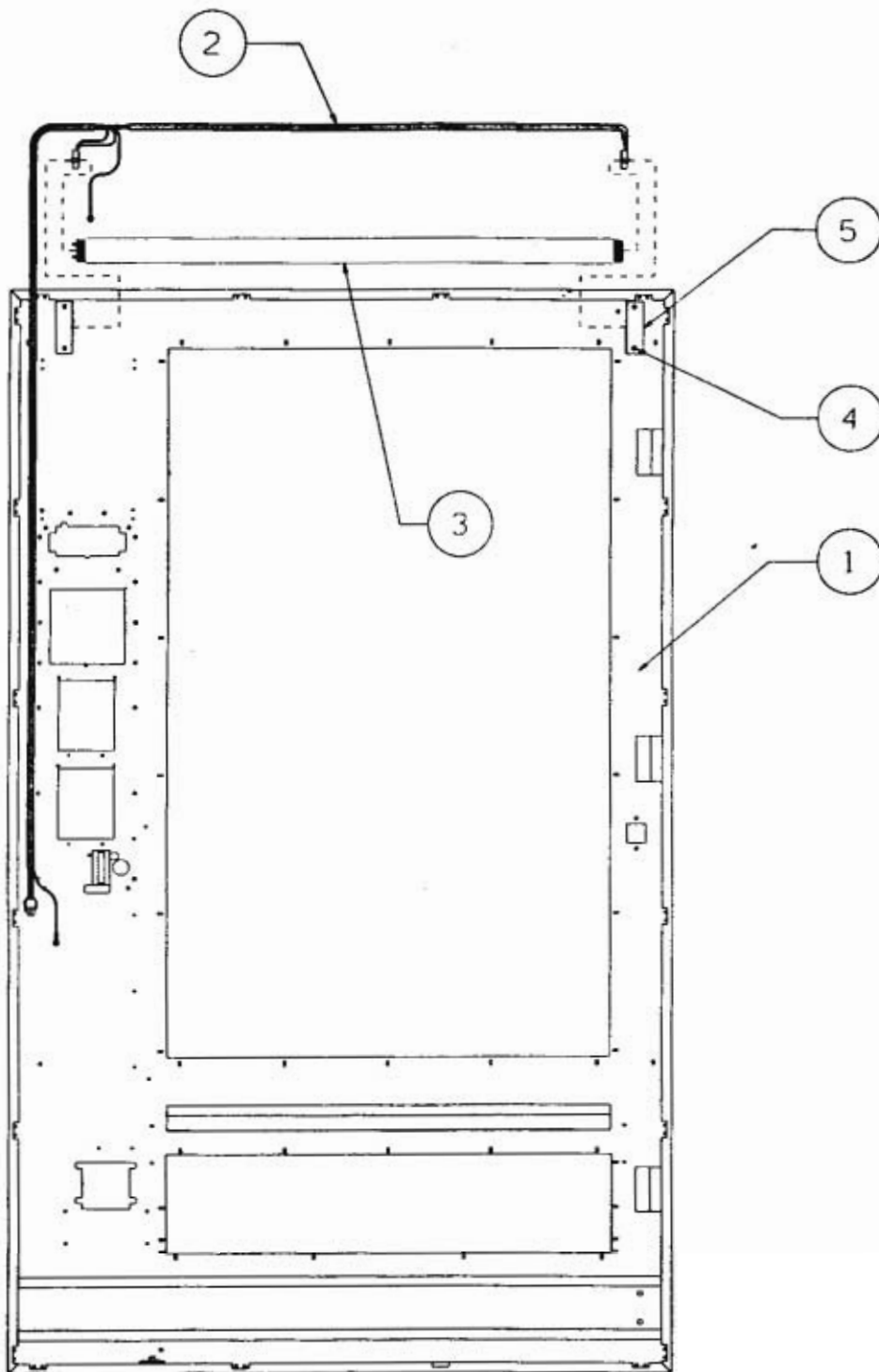

**FRONT DOOR LIGHT ASSEMBLY
MODEL B AND C
PARTS LIST**

ITEM	DESCRIPTION	PART NO.	QTY.
1	MAIN DOOR ASSEMBLY B MODEL	099-5533	1
	MAIN DOOR ASSEMBLY C MODEL	099-5534	1
2	DISPLAY LIGHT HARNESS	230-5028	2
3	FLUORESCENT LAMP MODEL B	18845	1
	FLUORESCENT LAMP MODEL C	18845	1
4	HEX NUT W/LOCKWASHER #8-32	20208	4
5	DISPLAY LIGHT BRACKET	220-4069	2

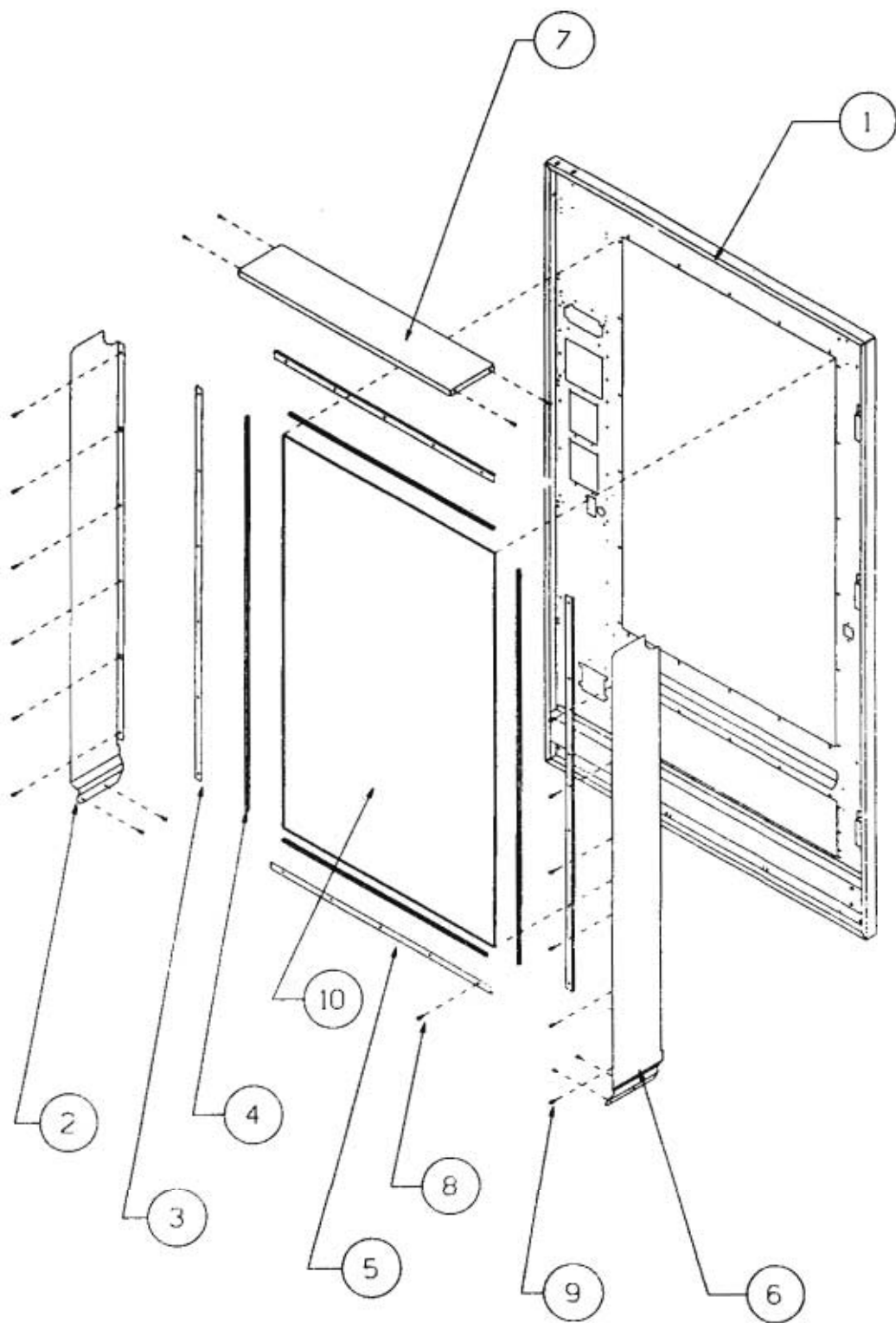

MAIN DOOR ASSEMBLY GLASS MOUNTING ASSEMBLY AND SHADOW BOX MODEL B AND C PARTS LIST

ITEM	DESCRIPTION	PART NO.	QTY.
1	FRONT DOOR ASSEMBLY MODEL B	099-5533	1
	FRONT DOOR ASSEMBLY MODEL C	099-5534	1
2	L.H. PRODUCT GUIDE	099-4010	1
3	GLASS RETAINER L/R	099-4003	2
4	DISPLAY GLASS GASKET VERTICAL	099-9007	2
5	GLASS RETAINER TOP/BOTTOM MODEL B	240-4023	2
	GLASS RETAINER TOP/BOTTOM MODEL C	210-4052	2
6	R.H. PRODUCT GUIDE	099-4011	1
7	PRODUCT GUIDE TOP SUPPORT MODEL B	240-4024	1
	PRODUCT GUIDE TOP SUPPORT MODEL C	224-4022	1
8	SCREW #8-18 X 3/8"	S39C818-12	10
9	SCREW #8-18 X 3/4"	S40C818-6	26
10	* DISPLAY GLASS MODEL B TEMPERED GLASS	099-9008	1
	* DISPLAY GLASS MODEL C TEMPERED GLASS	099-9009	1

* NOTE: WHEN REPLACING THE DOOR GLASS IN THIS MACHINE IT SHOULD ALWAYS BE TEMPERED GLASS.

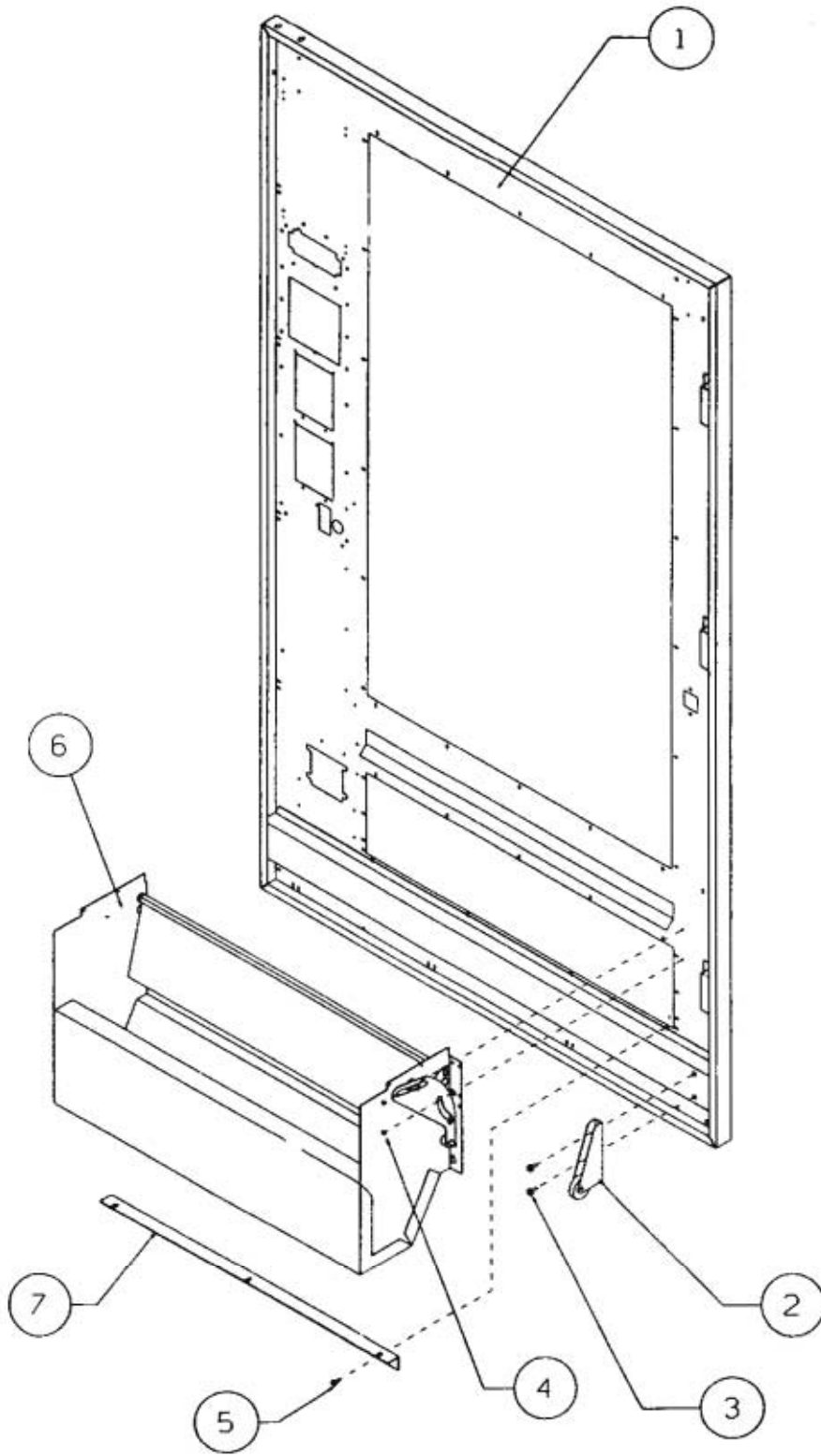

MAIN DOOR ASSEMBLY DELIVERY COMPARTMENT PARTS LIST

ITEM	DESCRIPTION	PART NO.	QTY.
1	FRONT DOOR ASSEMBLY MODEL B	099-5533	1
	FRONT DOOR ASSEMBLY MODEL C	099-5534	1
2	DOOR SUPPORT ROLLER ASSEMBLY	150-5244	1
3	SCREW W/LOCKWASHER	S20C2520-8	2
4	HEX NUT W/LOCKWASHER	20208	4
5	SCREW #8-18 X 3/8	S40C818-6	3
6	DELIVERY COMPARTMENT ASSEMBLY MODEL B	099-5016	1
	DELIVERY COMPARTMENT ASSEMBLY MODEL C	099-5017	1
7	SUPPORT DELIVERY TRAY MODEL B	240-4022	1
	SUPPORT DELIVERY TRAY MODEL C	240-4025	1

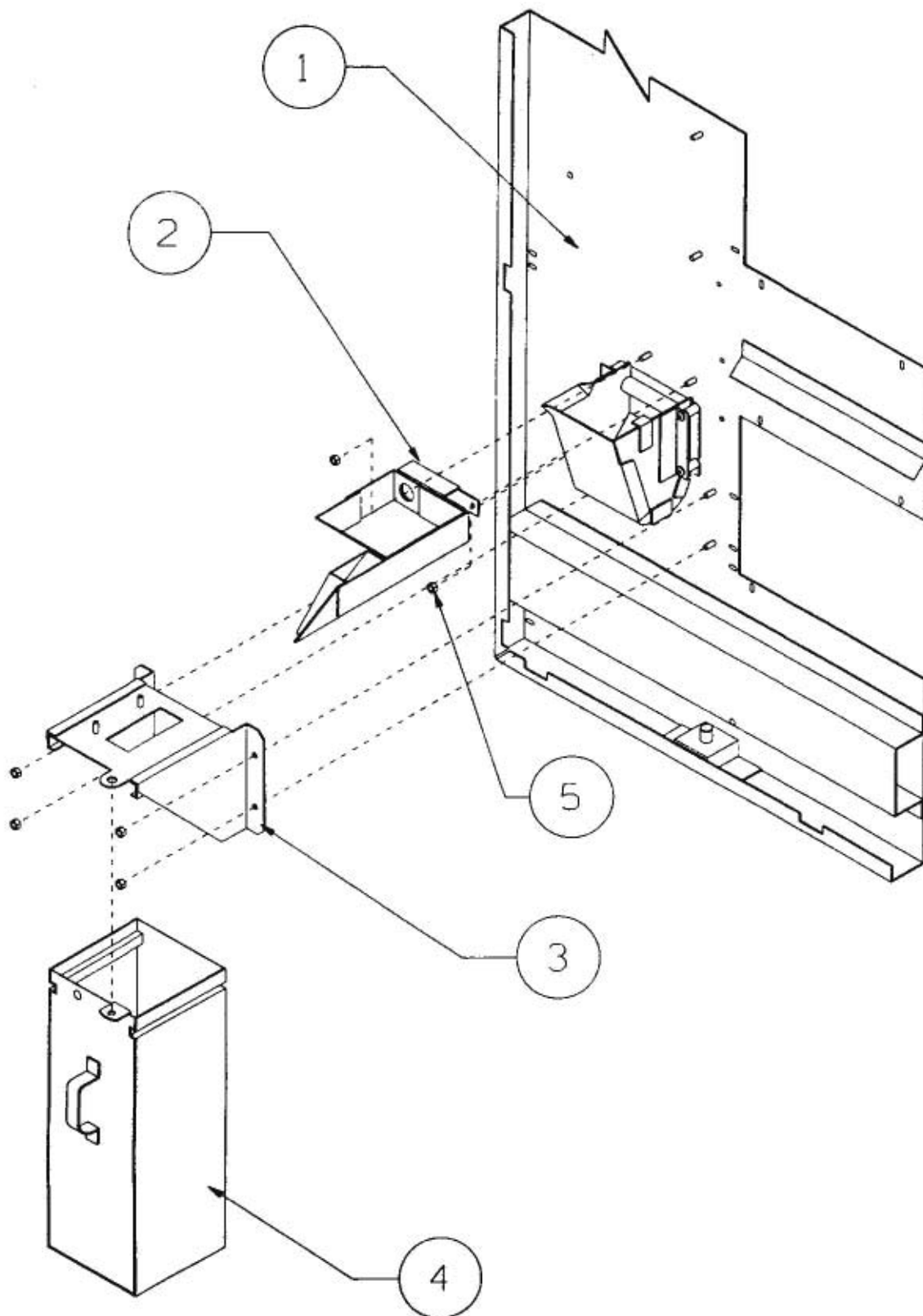

CASH BOX ASSEMBLY PARTS LIST

ITEM	DESCRIPTION	PART NO.	QTY.
1	FRONT DOOR ASSEMBLY MODEL B	099-5533	1
	FRONT DOOR ASSEMBLY MODEL C	099-5534	1
2	COIN HOPPER ASSEMBLY	098-5306	1
3	CASH BOX RETAINER	098-5292	1
4	CASH BOX ASSEMBLY	210-5080	1
5	HEX NUT #8-32 W/LOCKWASHER	20208	6

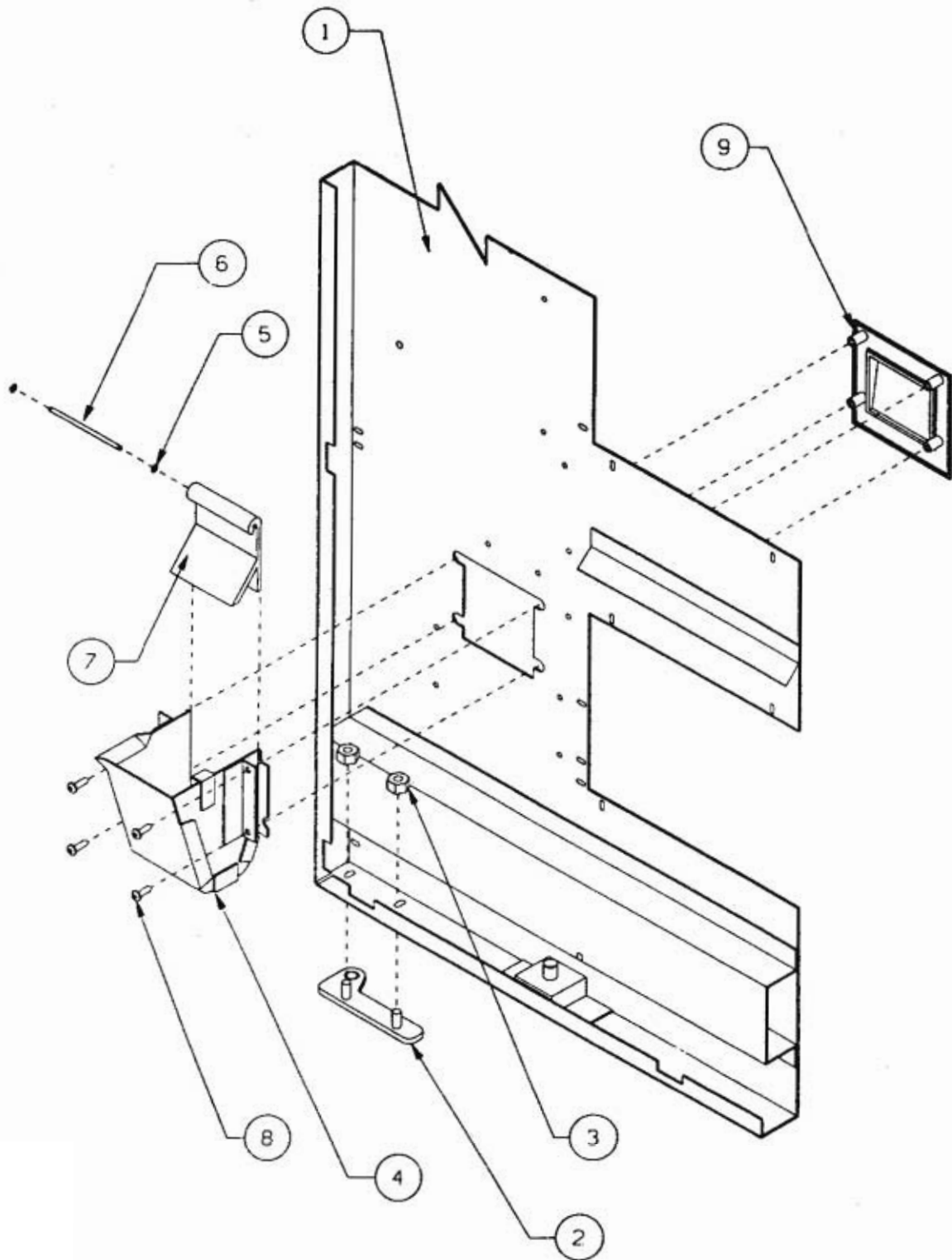

COIN RETURN CUP ASSEMBLY PARTS LIST

ITEM	DESCRIPTION	PART NO.	QTY.
1	FRONT DOOR ASSEMBLY MODEL B	099-5533	1
	FRONT DOOR ASSEMBLY MODEL C	099-5534	1
2	BOTTOM HINGE ASSEMBLY	150-5313BLK	1
3	HEX NUT #14-20	N20C2520	2
4	COIN RETURN CUP ASSEMBLY	001-5132	1
5	E-RING .125	R10K125	2
6	COIN RETURN PIN	099-6010	1
7	COIN RETURN DOOR	001-2004	1
8	SCREW #8-18 X 3/8	S39C818-6	4
9	FRONT COIN RETURN	001-2003SIL	1

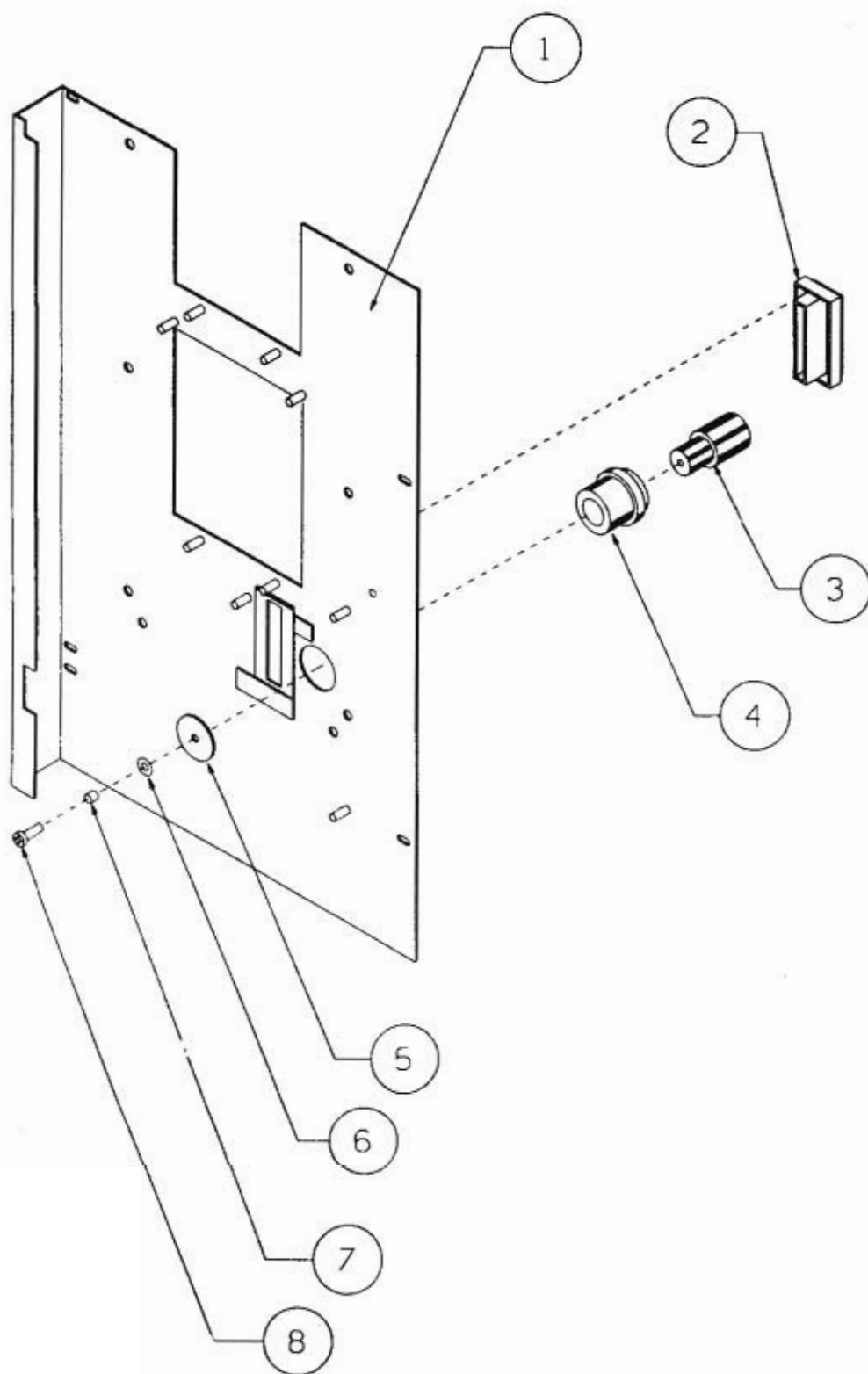

COIN RETURN BUTTON ASSEMBLY PARTS LIST

ITEM	DESCRIPTION	PART NO.	QTY.
1	FRONT DOOR ASSEMBLY MODEL B	099-5533	1
	FRONT DOOR ASSEMBLY MODEL C	099-5534	1
2	COIN INLET	17948	1
3	COIN REJECT BUTTON	21125	1
4	COIN REJECT BUSHING	21126	1
5	WASHER	16154	1
6	WASHER #8 X .188	13419	1
7	SPACER	22201	1
8	SCREW #8-18 X 1/2	02614BLK	1

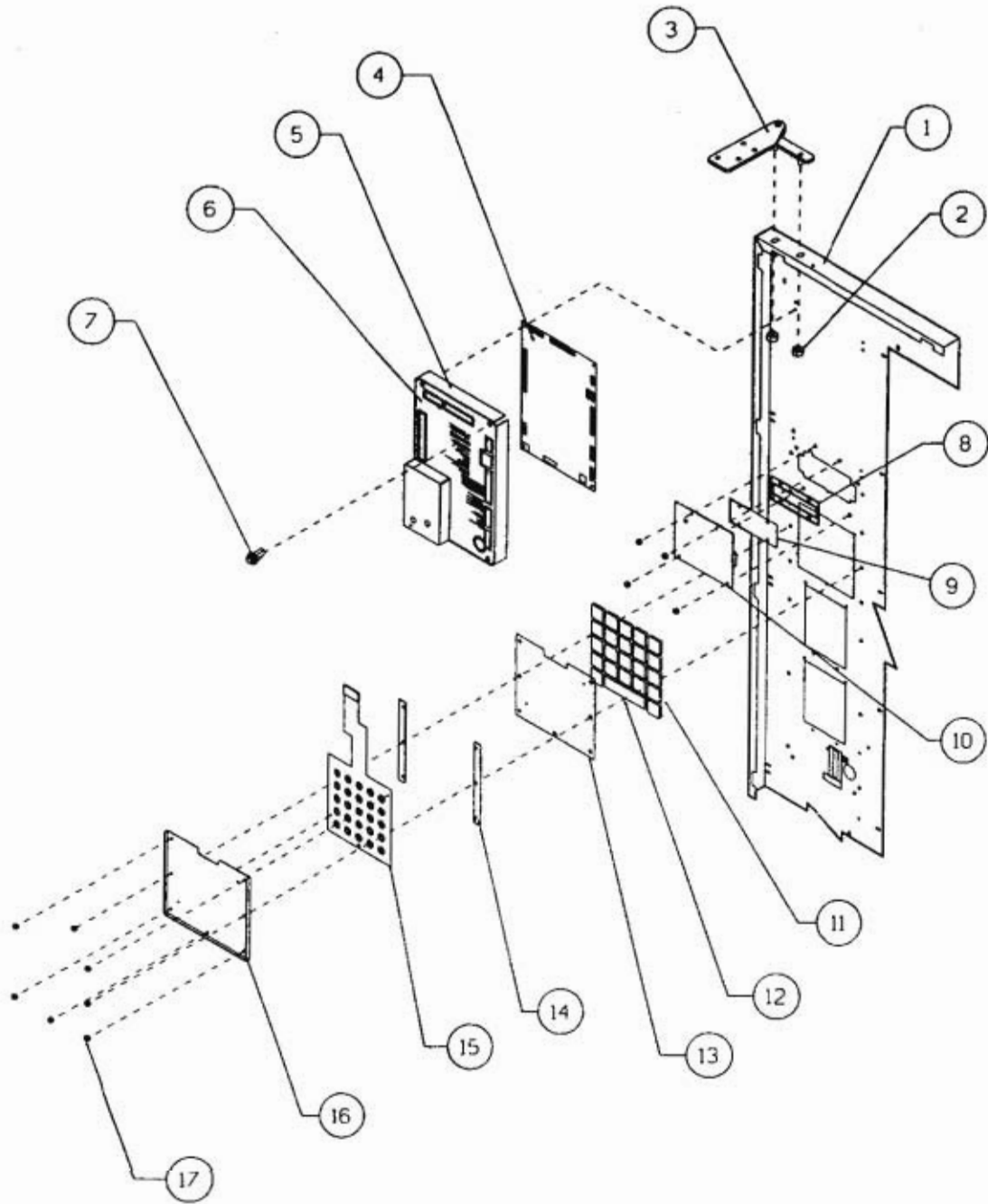

KEYPAD/CONTROL BOARD ASSEMBLY PARTS LIST

ITEM	DESCRIPTION	PART NO.	QTY.
1	FRONT DOOR ASSEMBLY MODEL B	099-5533	1
	FRONT DOOR ASSEMBLY MODEL C	099-5534	1
2	NUT 1/4-20	N20C2520	2
3	TOP DOOR HINGE ASSEMBLY	150-5316BLK	1
4	CONTROL BOARD	23357	1
5	CONTROL BOARD COVER	098-4353	1
6	COVER DECAL	098-8166	1
7	DEX JACK	098-8135	1
8	LENS	21061	1
9	DISPLAY FILTER	21060	1
10	MULTINATIONAL DISPLAY	21153	1
11	SELECTION BUTTON "A"	22909A	1
	SELECTION BUTTON "B"	22909B	1
	SELECTION BUTTON "C"	22909C	1
	SELECTION BUTTON "D"	22909D	1
	SELECTION BUTTON "E"	22909E	1
	SELECTION BUTTON "F"	22909F	1
	SELECTION BUTTON "G"	22909G	1
	SELECTION BUTTON "H"	22909H	1
	SELECTION BUTTON "0"	229090	1
	SELECTION BUTTON "1"	229091	1
	SELECTION BUTTON "2"	229092	1
	SELECTION BUTTON "3"	229093	1
	SELECTION BUTTON "4"	229094	1
	SELECTION BUTTON "5"	229095	1
	SELECTION BUTTON "6"	229096	1
	SELECTION BUTTON "7"	229097	1
	SELECTION BUTTON "8"	229098	1
	SELECTION BUTTON "9"	229099	1
	SELECTION BUTTON "10"	2290910	1
	SELECTION BUTTON "11"	2290911	1
	SELECTION BUTTON "12"	2290912	1
	SELECTION BUTTON "13"	2290913	1
12	PRESS TO VIEW BUTTON	2346201	1
13	SPACER B/C/D KEYPAD	098-8170	1
14	SHIM B/C/D KEYPAD	098-4355U	2
15	KEYPAD	098-8167	1
16	KEYPAD BACKING PLATE	098-4354	1
17	HEX NUT #8-32	20208	9

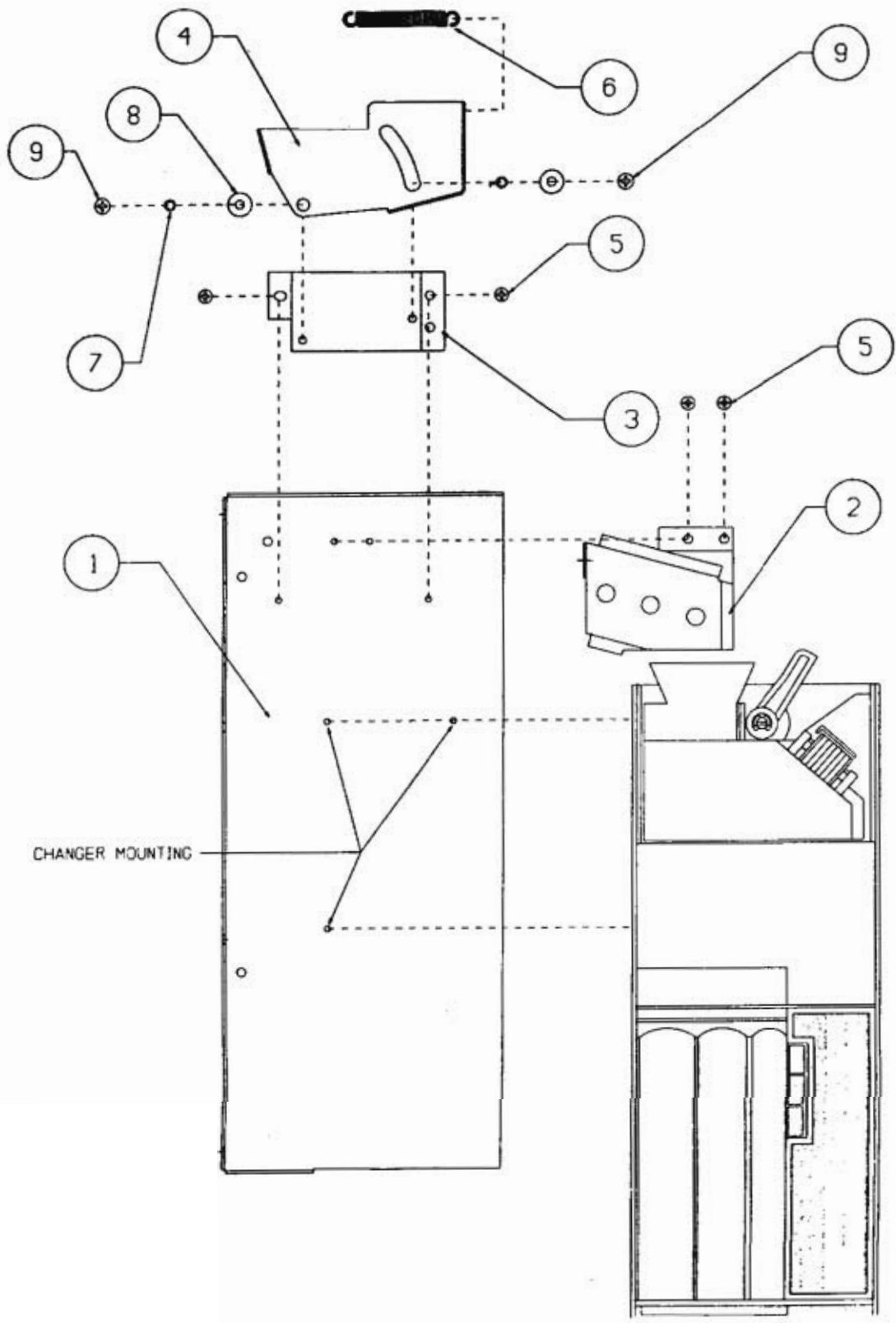

COIN RETURN ASSEMBLY CHANGER PARTS LIST

ITEM	DESCRIPTION	PART NO.	QTY.
1	COIN MECH. MOUNTING PLATE	098-5339	1
2	UPPER COIN CHUTE ASSEMBLY	099-5542	1
3	REJECT SPACER BRACKET	21316	1
4	COIN REJECT LEVER	098-5323	1
5	SCREW #8-18 X 3/8	01298BLK	4
6	EXTENSION SPRING	00611	1
7	SPACER	22201	2
8	FLAT WASHER	04280	2
9	SCREW #10-24	22482	2
10	CHANGER COINCO	21240	1

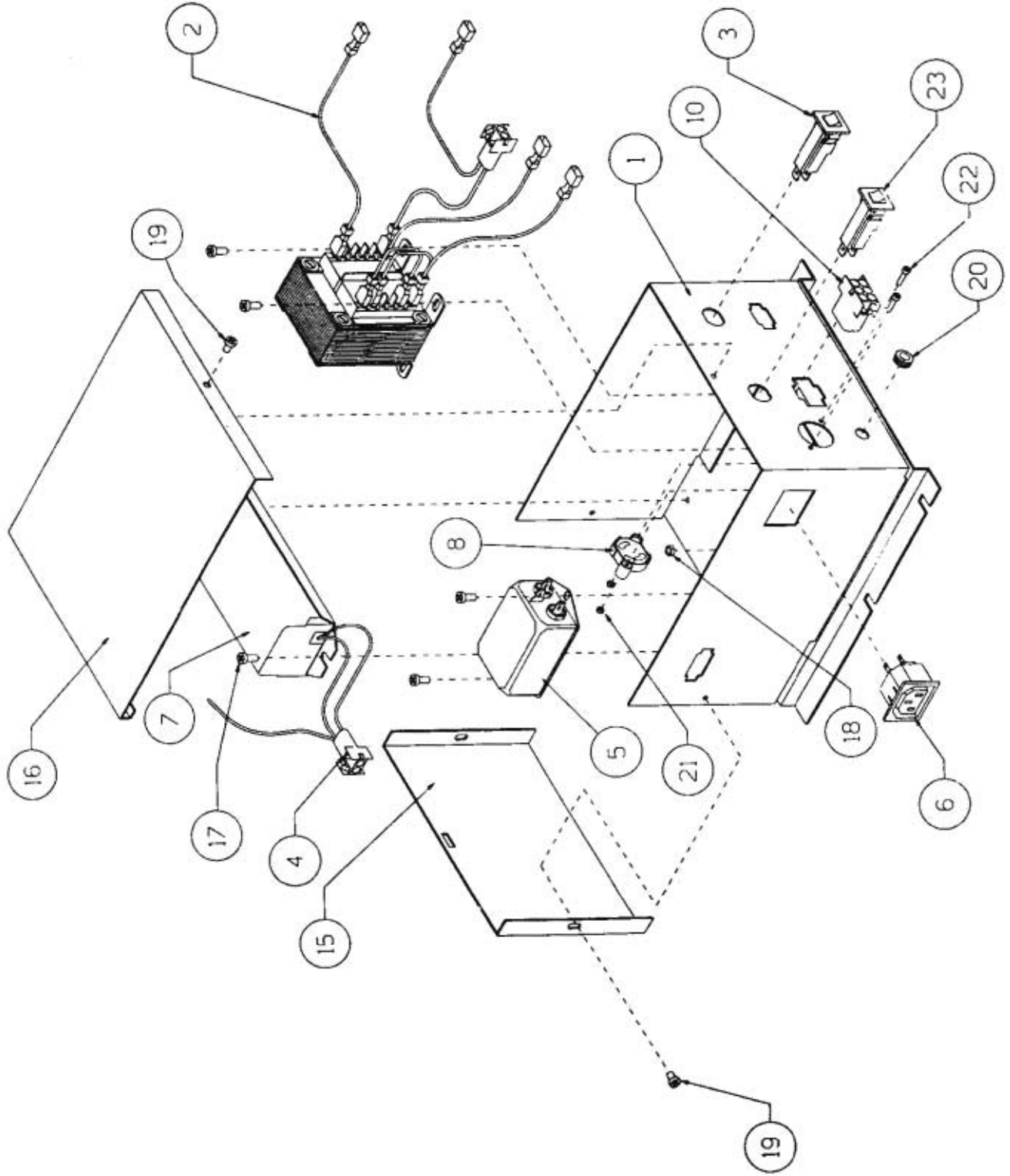

POWER BOX ASSEMBLY PARTS LIST

ITEM	DESCRIPTION	PART NO.	QTY.
1	POWER BOX	099-5573	1
2	TRANSFORMER	099-5571	1
3	3 AMP CIRCUIT BREAKER	2233002	1
4	CAP HOUSING 3 CIRCUIT	097-8038	1
5	RFI FILTER	20758	1
6	APPLIANCE OUTLET	19663	1
7	BALLAST 13 W 115V	099-5574	1
8	STARTER SOCKET ASSEMBLY	098-5204	1
9	GROUND HARNESS	099-5575	1
10	6 CIR. CAP HOUSING	210-8005	1
12	POWER FEED HARNESS	099-5576	1
13	CIR BRKE FEED HRNS.	099-5577	1
15	POWER BOX BACK	099-4212	1
16	POWER BOX COVER	099-4213	1
17	SCREW #8-32	01715	5
18	NUT #8-32	20208	1
19	SCREW #8-18	01868	3
20	GROMMET 3/8" HOLE	001-8020	1
21	HEX NUT M3	N24CM3	2
22	SCREW	S16CM3-14	2
23	15 AMP CIRCUIT BREAKER	2233005	1

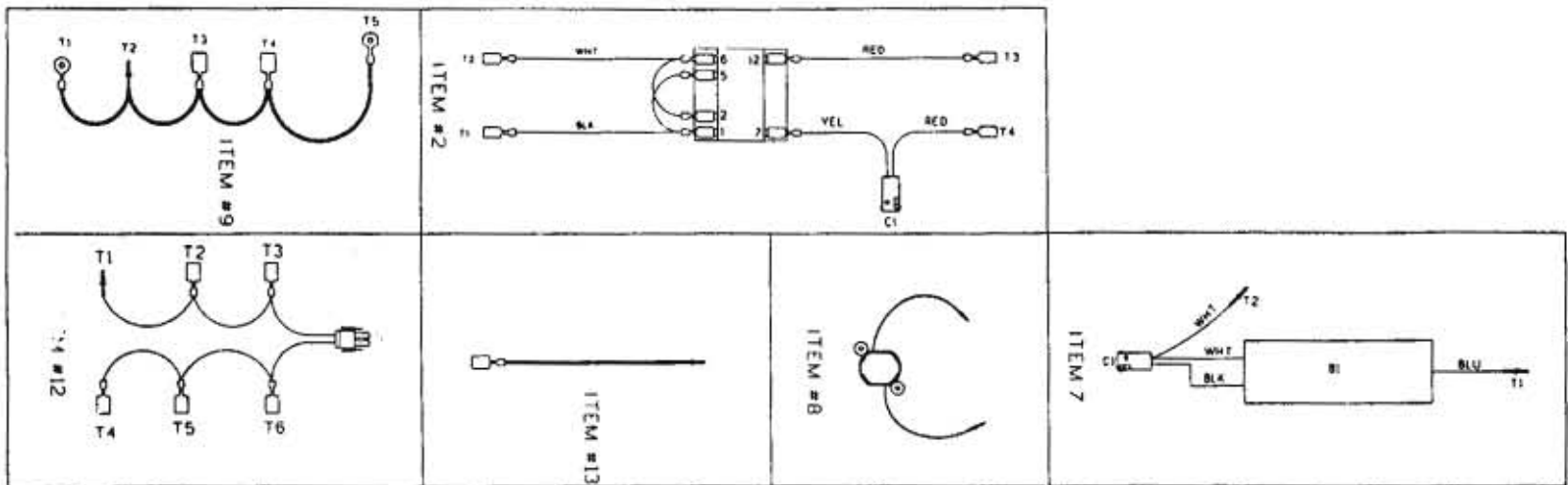

WIRING CONNECTIONS

ITEM	PART NO	FROM TERM. / TO TERM.
9	099-5575	STUD/4-3/5-2/6-GRD/20
2	099-5571	BLK/5-5 . WHT/5-4 . RED/3-1 . RED/3-2. C1-1
7	099-5574	T1/10-3, C1/12-P1
12	099-5576	P1/7-C1, T1/4-2/T2/5-1, T3/6-N, T4/23-2, T5/6-C, T6/5-2
13	099-5577	4-L/23-1
8	098-5204	10-5 . 10-6

PART NO	USAGE	QTY
13140	DELIVERY TRAY TRIM AND HORIZONTAL TRIM AS SHOWN	20
539C818-12	AROUND DISPLAY GLASS	20
540C620-B	SERVICE DOOR SIDE TRIM AND SERVICE DOOR END TRIM	40

NOTE: THIS DETAIL APPLIES TO LEKTROVEND AND POLYVEND "A" / "C" MODEL SNACK MACHINE TRIM INSTALLATION ONLY. SEE TRIM AND PANEL ASSEMBLIES FOR STYLE, SERIES AND MODEL.

PT NO 540C620-B
SCREW, SHEET METAL,
PHILLIPS PAN HEAD,
TYPE "B" #6-20 x 1/2

PT NO 539C818-12
SCREW, SHEET METAL,
PHILLIPS PAN HEAD,
TYPE "B" #8-18 x 3/4

PT NO 540C620-B
SCREW, SHEET METAL,
PHILLIPS PAN HEAD,
TYPE "B" #6-20 x 1/2

PT NO 13140
SCREW #10-24 x 5/16
PANHD PHIL
TYPE "F"

HORIZONTAL TRIM
NOTE PT NO 13140 USED
(4) PLACES MARKED "A"

PT NO 13140
SCREW #10-24 x 5/16
PANHD PHIL
TYPE "F"

FRONT DOOR TRIM SCREWS

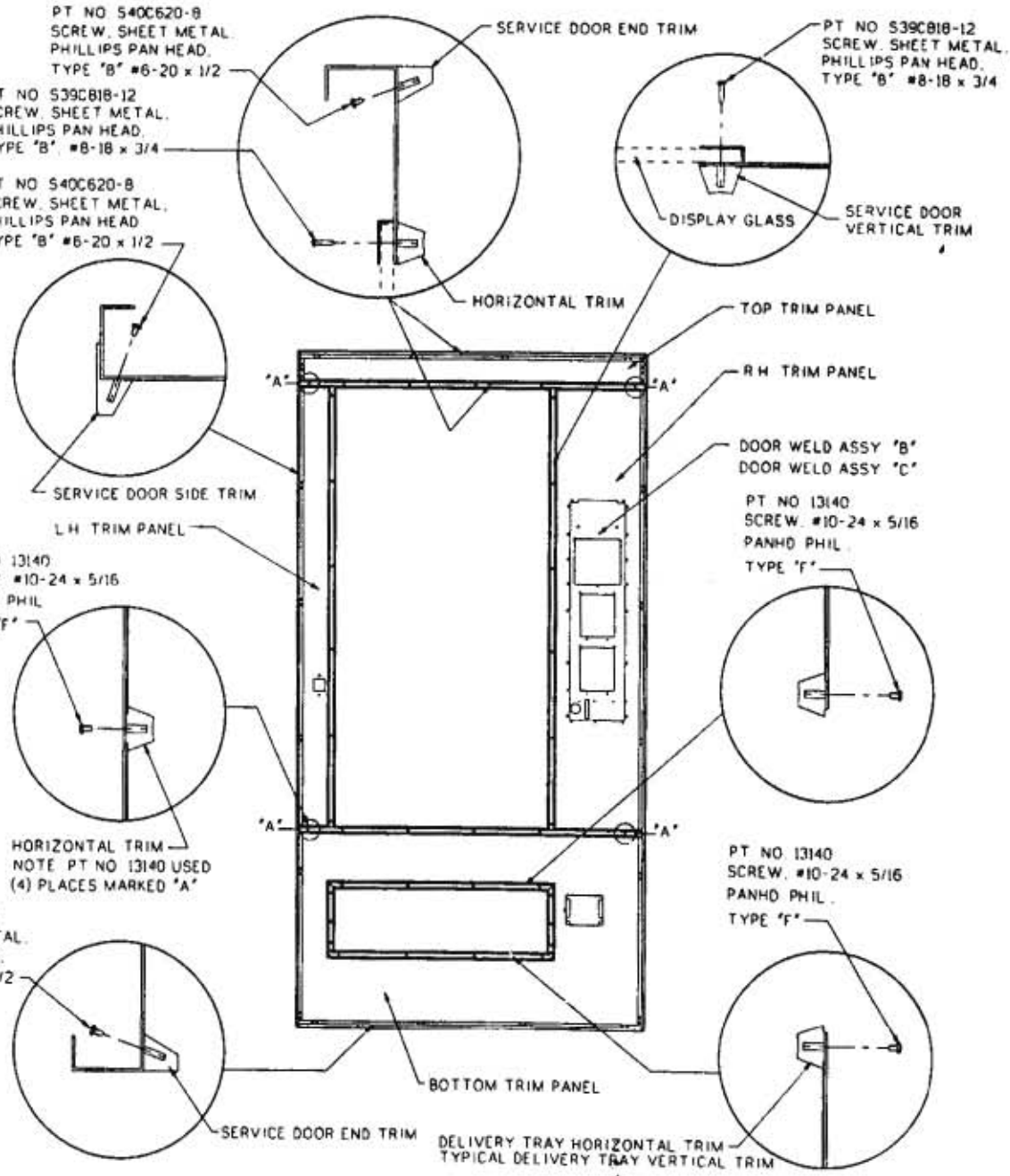

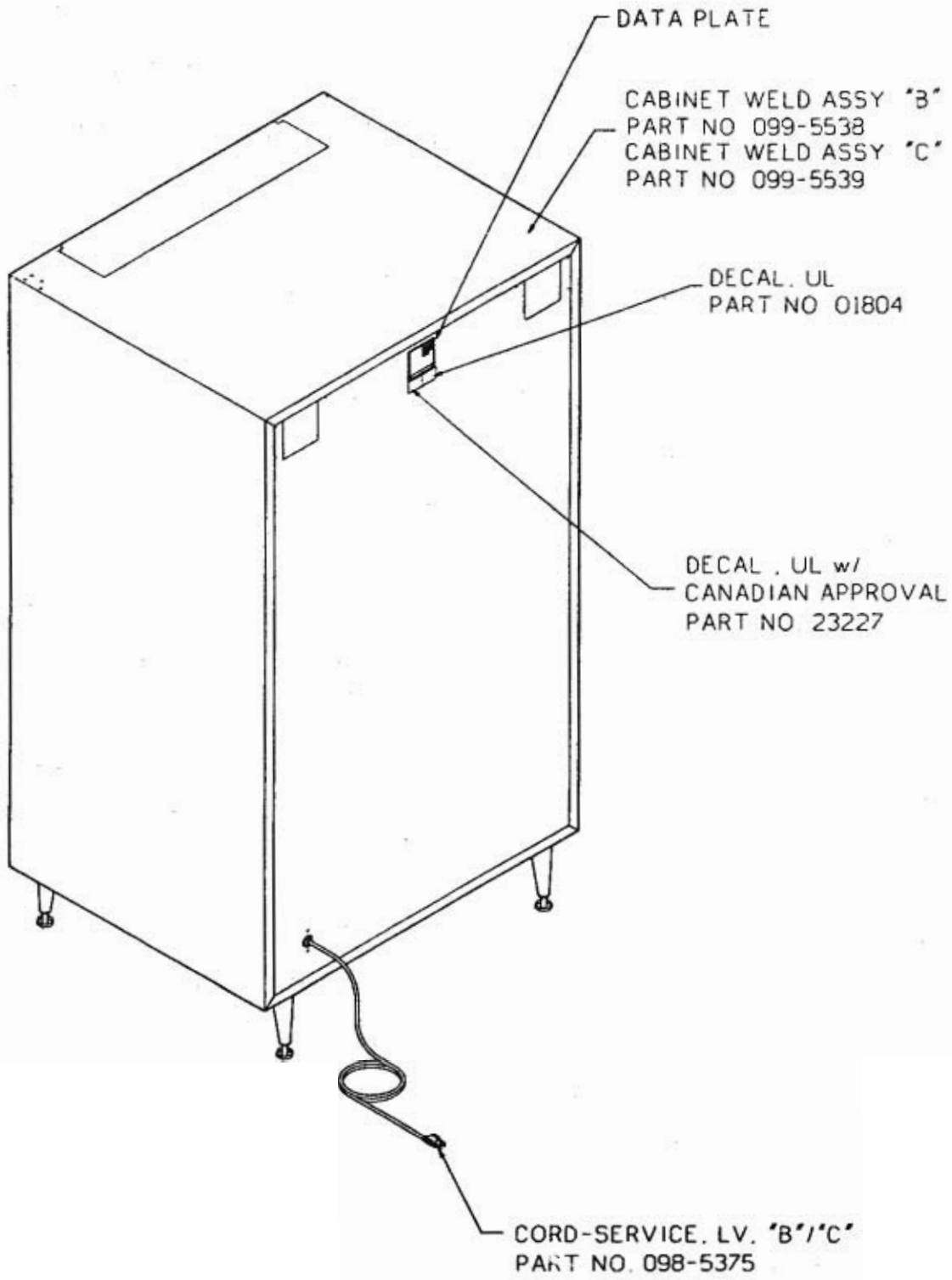

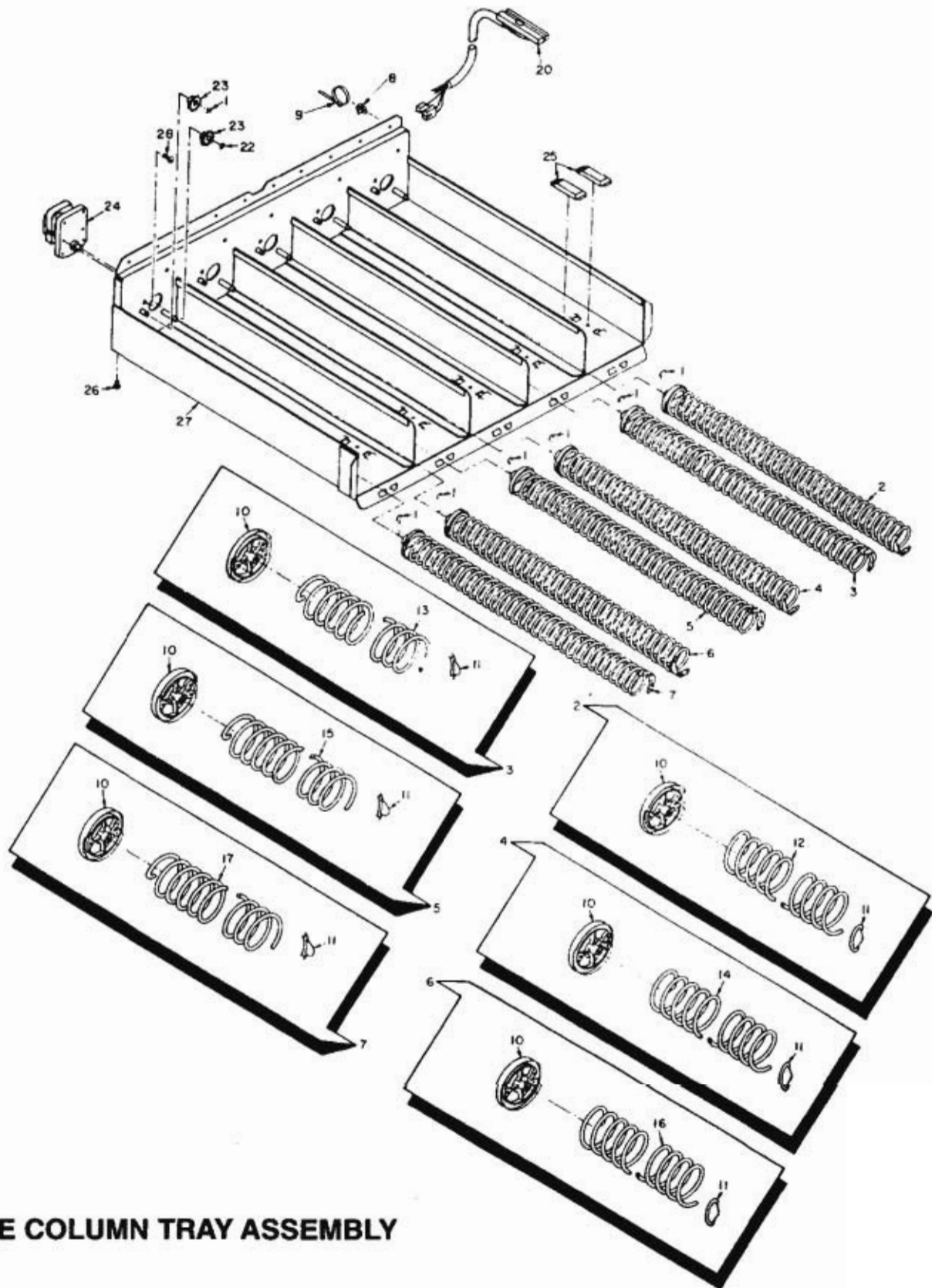

WIDE COLUMN TRAY ASSEMBLY

WIDE COLUMN TRAY ASSEMBLY

ITEM	DESCRIPTION	PART NO.	QTY.	
			Model B	Model C
1	RETAINING RING 5/16	R10K312	12	15
2	RIGHT HAND SPRING AUGER ASSEMBLY 1 1/2" PITCH	210-5123	0-4	0-5
3	LEFT HAND SPRING AUGER ASSEMBLY 1 1/2" PITCH	210-5124	0-4	0-5
4	RIGHT HAND SPRING AUGER ASSEMBLY 1 3/4" PITCH	210-5125	0-4	0-5
5	LEFT HAND SPRING AUGER ASSEMBLY 1 3/4" PITCH	210-5126	0-4	0-5
6	RIGHT HAND SPRING AUGER ASSEMBLY 2" PITCH	210-5127	0-4	0-5
7	LEFT HAND SPRING AUGER ASSEMBLY 2" PITCH	210-5028	0-4	0-5
8	PUSH MOUNT	099-8062	1	1
9	TY RAP	001-8103	1	1
10	DRIVE GEAR - HELIX	210-3006	8	10
11	EJECTOR	210-3020	8	10
12	RIGHT HAND SPRING AUGER 1 1/2" PITCH	210-7015	0-4	0-5
13	LEFT HAND SPRING AUGER 1 1/2" PITCH	210-7016	0-4	0-5
14	RIGHT HAND SPRING AUGER 1 3/4" PITCH	210-7011	0-4	0-5
15	LEFT HAND SPRING AUGER 1 3/4" PITCH	210-7012	0-4	0-5
16	RIGHT HAND SPRING AUGER 2" PITCH	210-7017	0-4	0-5
17	LEFT HAND SPRING AUGER 2" PITCH	210-7018	0-4	0-5
20	TRAY WIRE HARNESS - 4 COLUMN	2146301	1	0
	TRAY WIRE HARNESS - 5 COLUMN	2146401	0	1
22	PUSHNUT	210-8017	4	5
23	DRIVE GEAR	210-3005	8	10
24	DRIVE MOTOR	099-8017	4	5
25	WEAR PAD	210-3010	8	10
26	CANOE CLIP .100 ROUND HEAD	210-8021	2	3
27	MAIN TRAY WELDMENT - 4 COLUMN	099-5053	1	0
	MAIN TRAY WELDMENT - 5 COLUMN	099-5055	0	1
28	SCREW NO. 8-32X3/8	S41C832-6	8	10

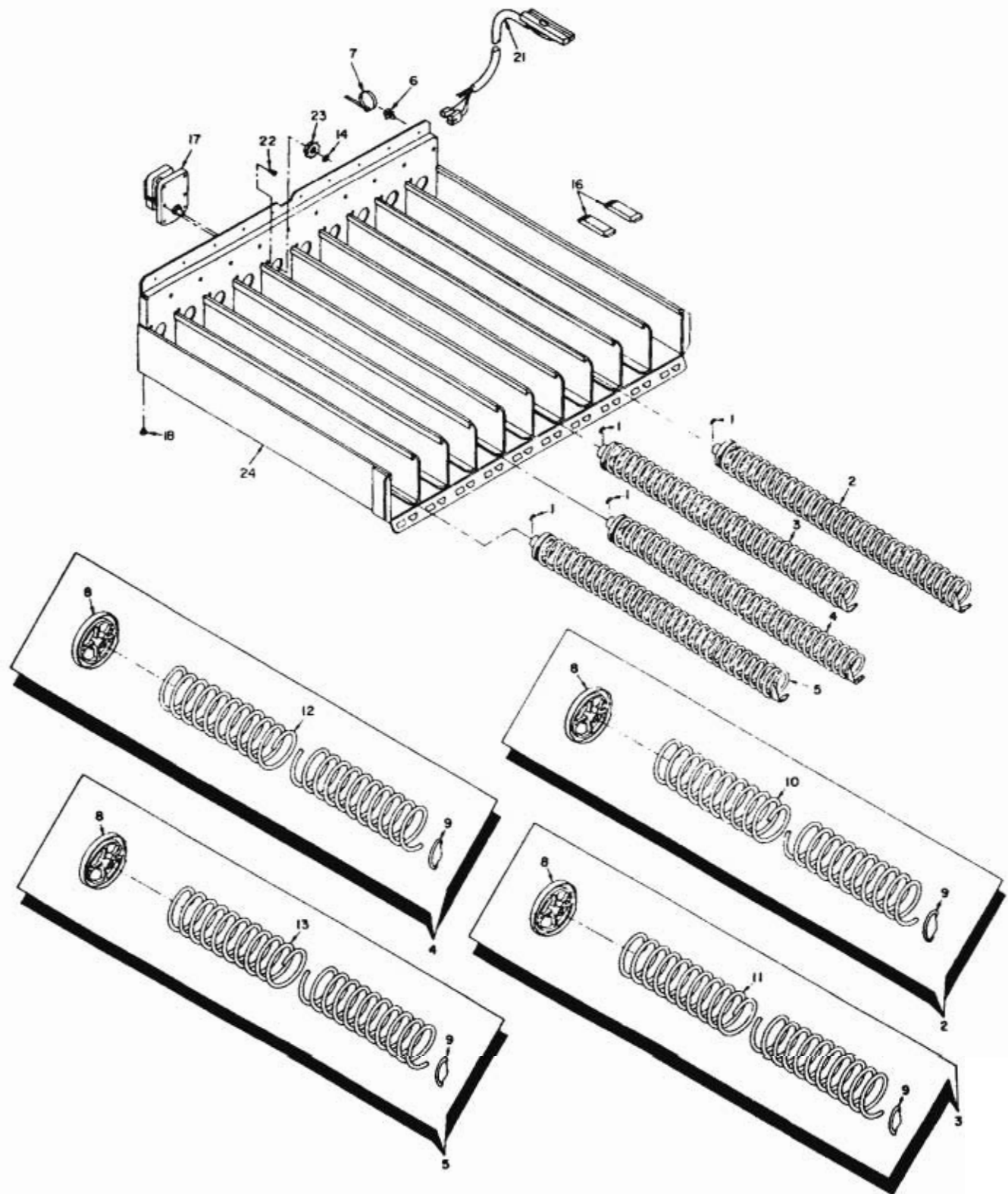

NARROW COLUMN TRAY ASSEMBLY

NARROW COLUMN TRAY ASSEMBLY

ITEM	DESCRIPTION	PART NO.	QTY.	
			Model B	Model C
1	RETAINING RING 5/16	R10K312	8	10
2	RIGHT HAND SPRING AUGER ASSEMBLY 13/16" PITCH	210-5120	1	1
3	RIGHT HAND SPRING AUGER ASSEMBLY 1" PITCH	210-5121	3	5
4	RIGHT HAND SPRING AUGER ASSEMBLY 1 13/16" PITCH	210-5122	3	3
5	RIGHT HAND SPRING AUGER ASSEMBLY 1 1/2" PITCH	210-5123	1	1
6	PUSH MOUNT	099-8062	1	1
7	TY RAP	001-8103	1	1
8	DRIVE GEAR - HELIX	210-3006	8	10
9	EJECTOR	210-3020	8	10
10	RIGHT HAND SPRING AUGER 13/16" PITCH	210-7013	1	1
11	RIGHT HAND SPRING AUGER 1" PITCH	210-7010	3	5
12	RIGHT HAND SPRING AUGER 1 3/16" PITCH	210-7014	3	3
13	RIGHT HAND SPRING AUGER 1 1/2" PITCH	210-7015	1	1
14	PUSHNUT	210-8017	8	10
16	WEAR PAD	210-3010	8	10
17	DRIVE MOTOR	099-8017	8	10
18	CANOE CLIP .100 ROUND HEAD	210-8021	2	3
21	TRAY WIRE HARNESS - 8 COLUMN	2146501	1	0
	TRAY WIRE HARNESS - 10 COLUMN	2146201	0	1
22	SCREW NO. 8-32X3/8	S41C832-6	16	20
23	DRIVE GEAR	210-3005	8	10
24	TRAY WELDMENT - 8 COLUMN	099-5057	1	0
	TRAY WELDMENT - 10 COLUMN	099-5058	0	1

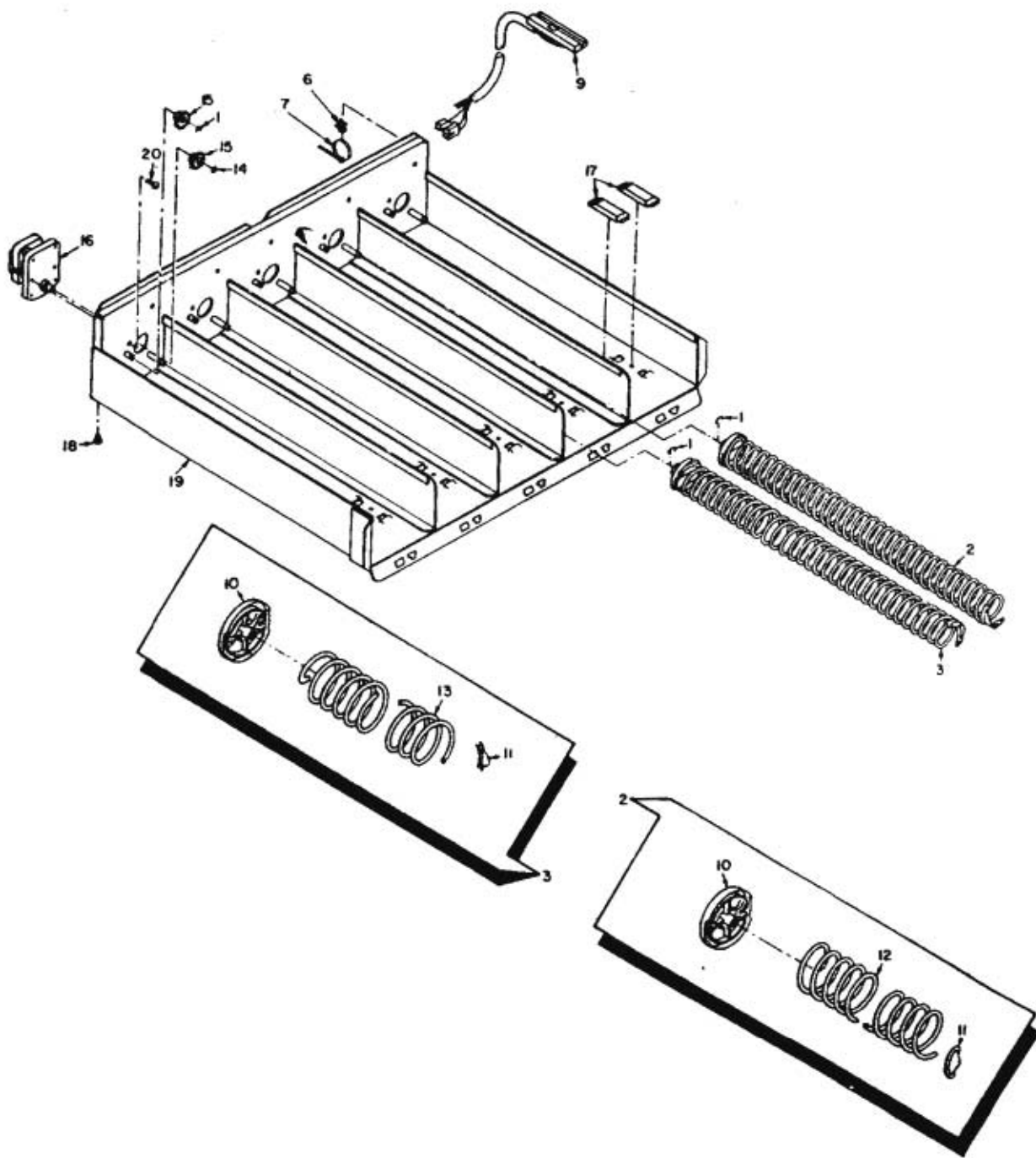

TOP TRAY ASSEMBLY COMPLETE

TOP TRAY ASSEMBLY COMPLETE

ITEM	DESCRIPTION	PART NO.	QTY.	
			Model B	Model C
1	RETAINING RING 5/16	R10K312	12	15
2	RIGHT HAND SPRING AUGER ASSEMBLY 1 3/4" PITCH	210-5125	4	5
3	LEFT HAND SPRING AUGER ASSEMBLY 1 3/4" PITCH	210-5126	4	5
6	PUSH MOUNT	099-8062	1	1
7	TY RAP	001-8103	1	1
9	TRAY WIRE HARNESS - 4 COLUMN	2146301	1	0
	TRAY WIRE HARNESS - 5 COLUMN	2146401	0	1
10	DRIVE GEAR HELIX	210-3006	8	10
11	EJECTOR	210-3020	8	10
12	RIGHT HAND SPRING AUGER 1 3/4" PITCH	210-7011	4	5
13	LEFT HAND SPRING AUGER 1 3/4" PITCH	210-7012	4	5
14	PUSHNUT	210-8017	4	5
15	DRIVE GEAR	210-3005	8	10
16	DRIVE MOTOR	099-8017	4	5
17	WEAR PAD	210-3010	8	10
18	CANOE CLIP .100 ROUND HEAD	210-8021	2	3
19	MAIN TRAY WELDMENT - 4 COLUMN TOP	099-5052	1	0
	MAIN TRAY WELDMENT - 5 COLUMN TOP	099-5054	0	1
20	SCREW NO. 8-32X3/8	S41C832-6	8	10

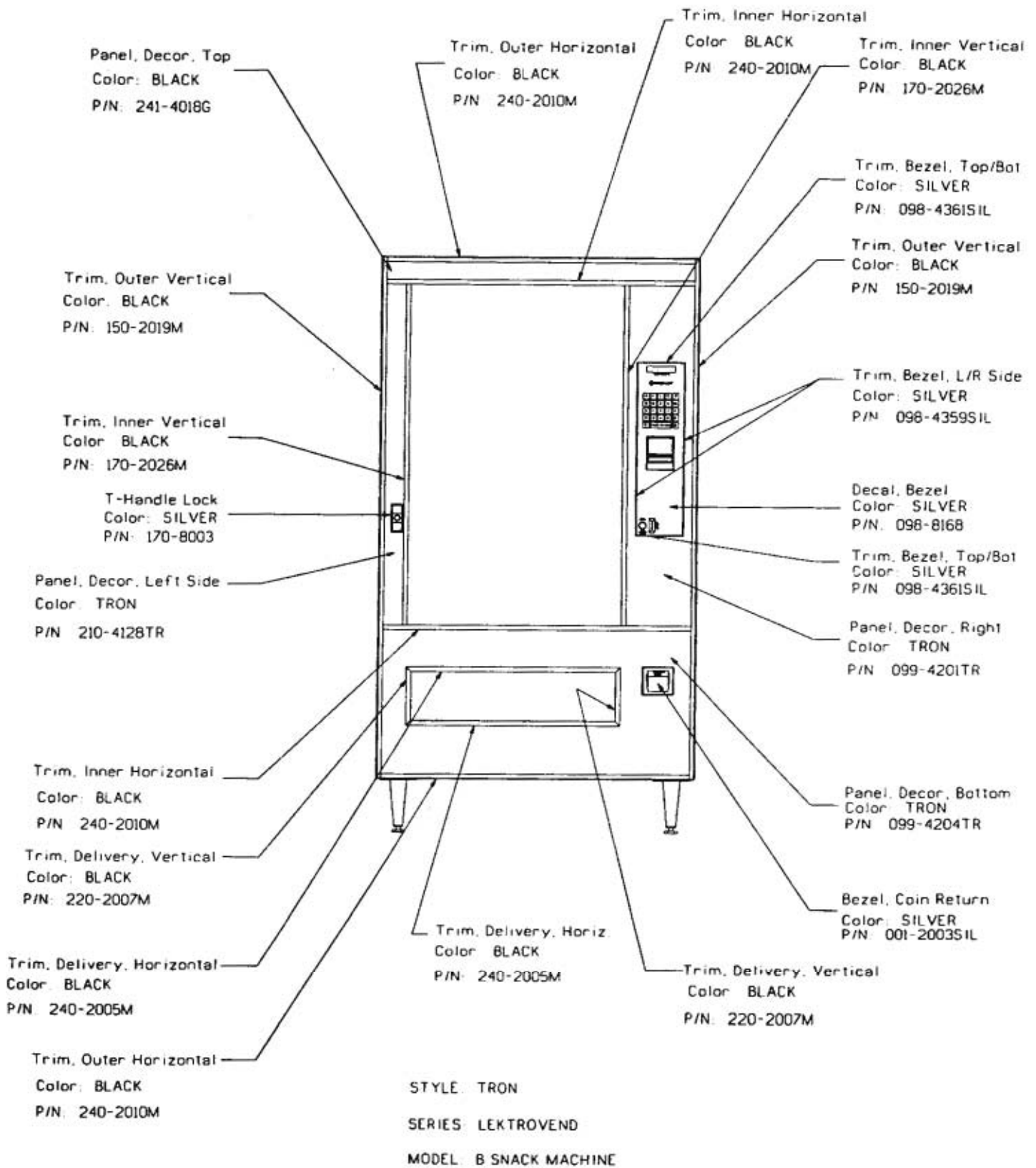

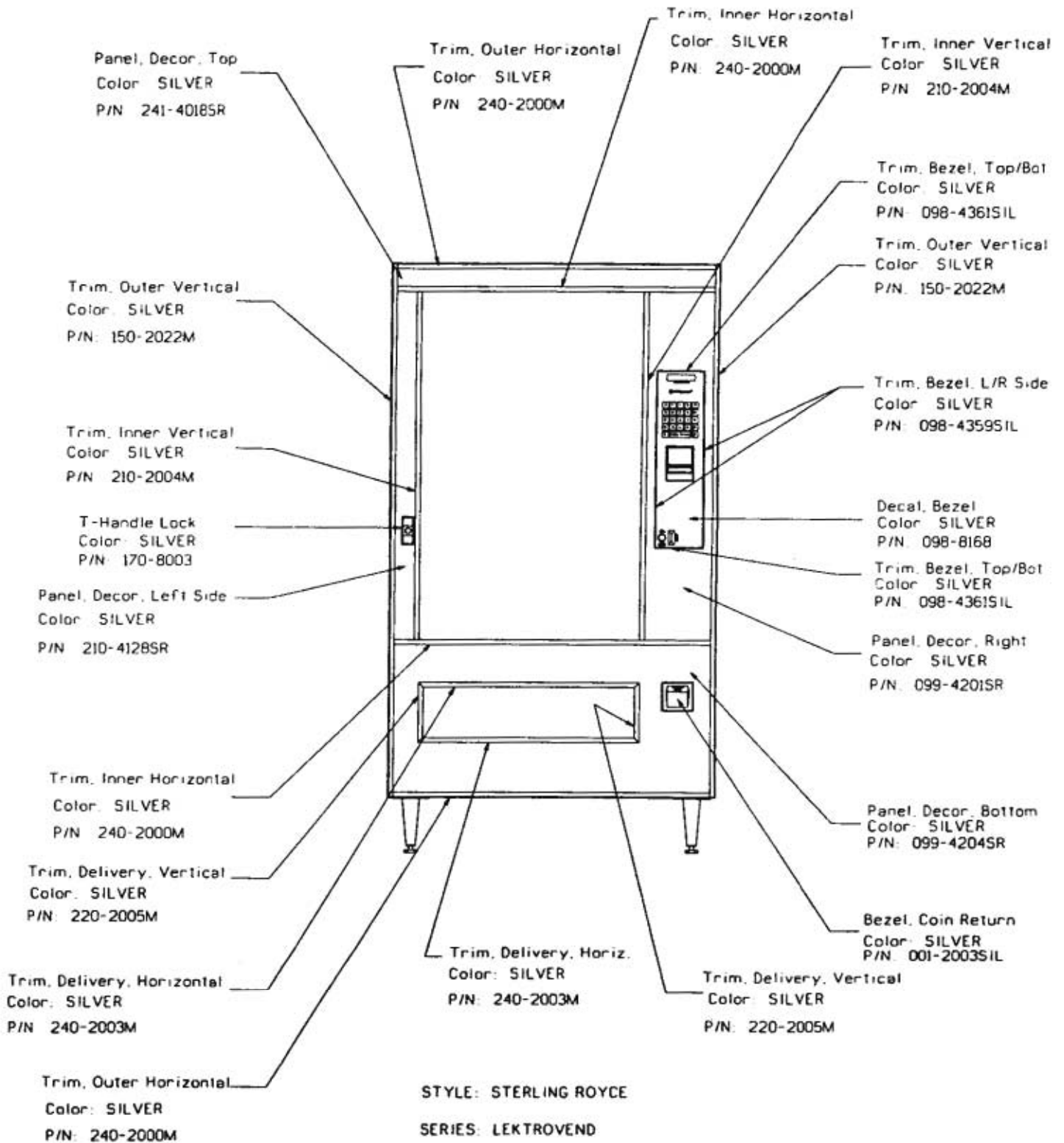

STYLE: STERLING ROYCE
 SERIES: LEKTROVEND
 MODEL: B SNACK MACHINE

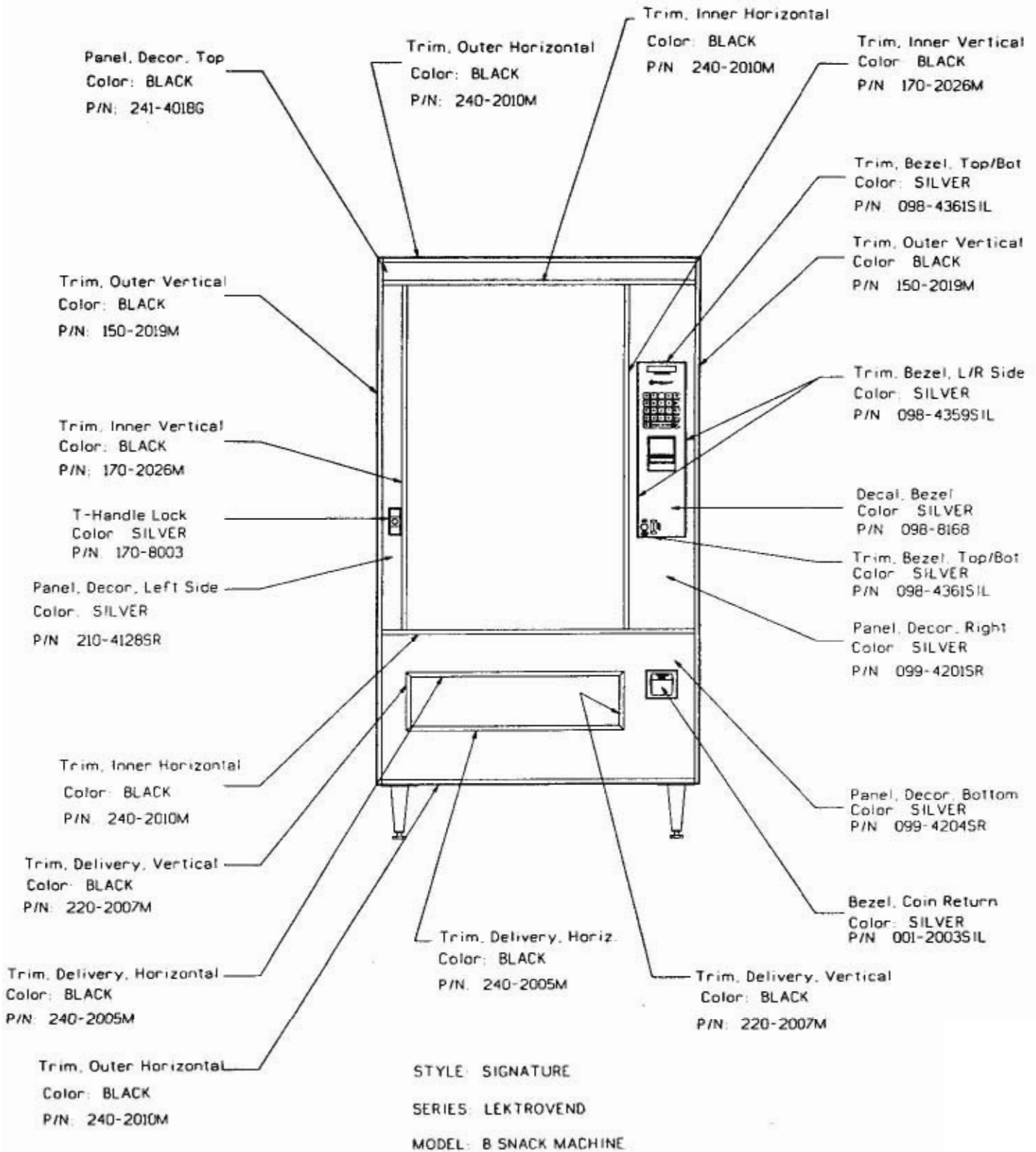

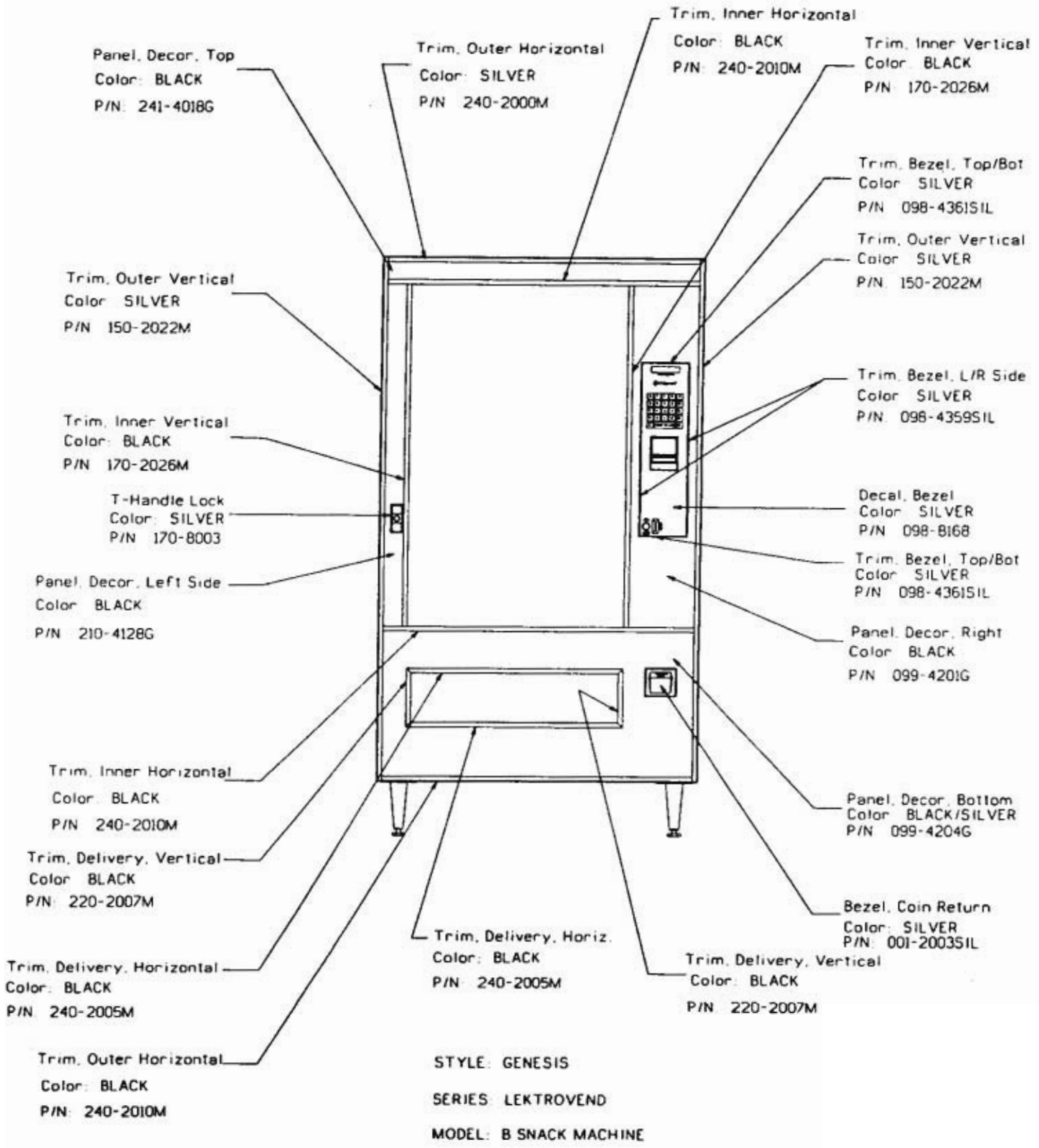

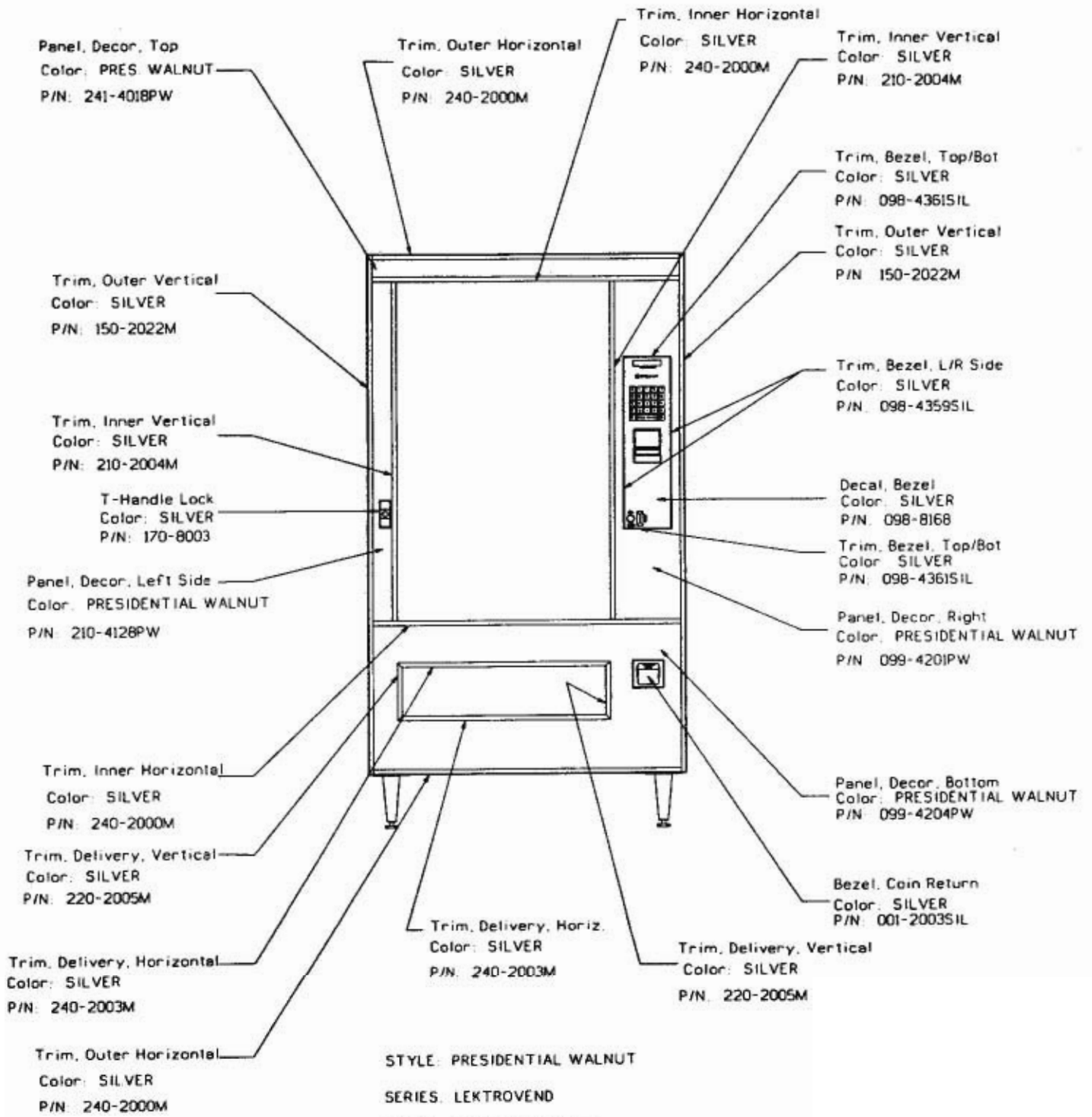

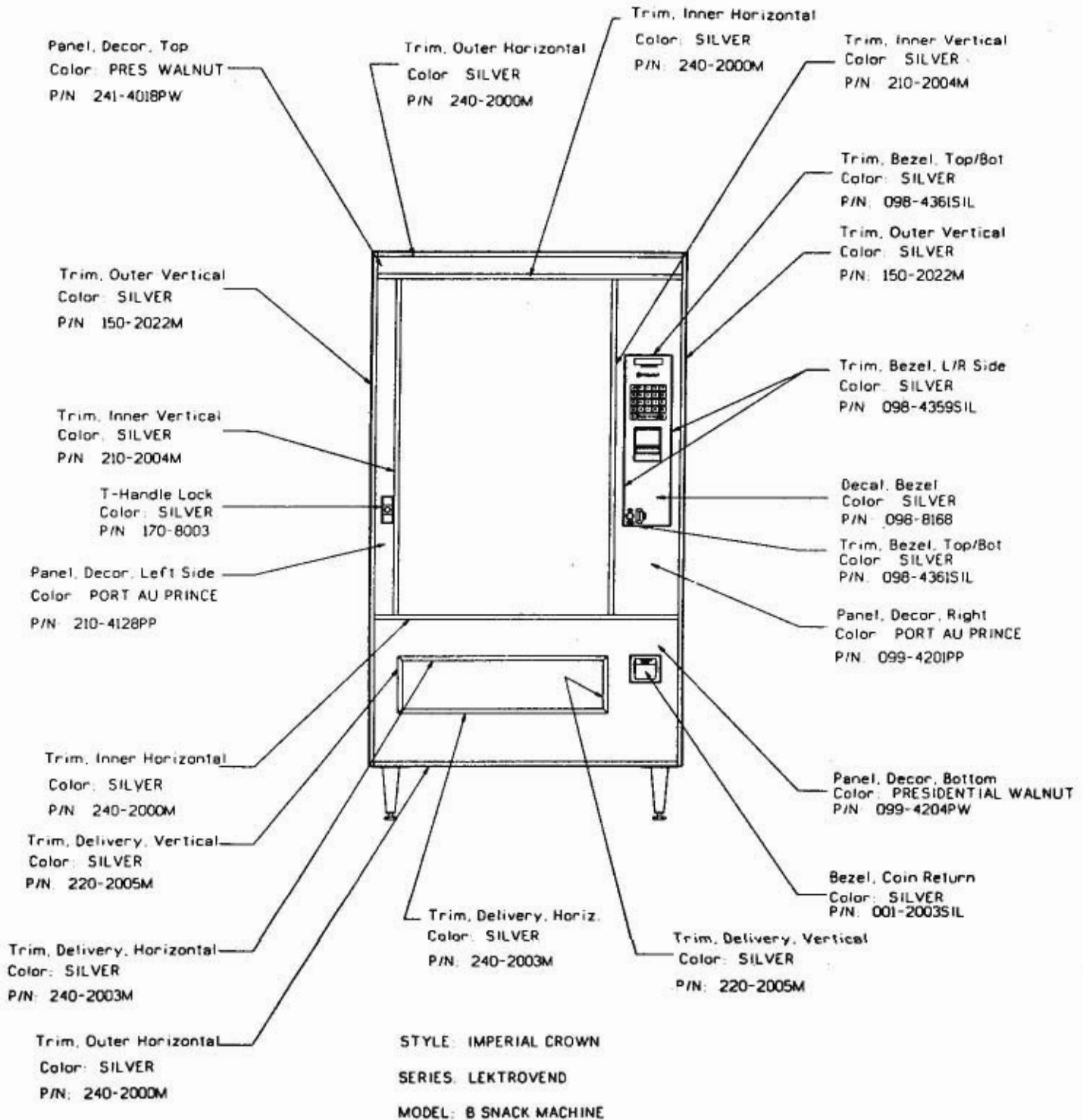

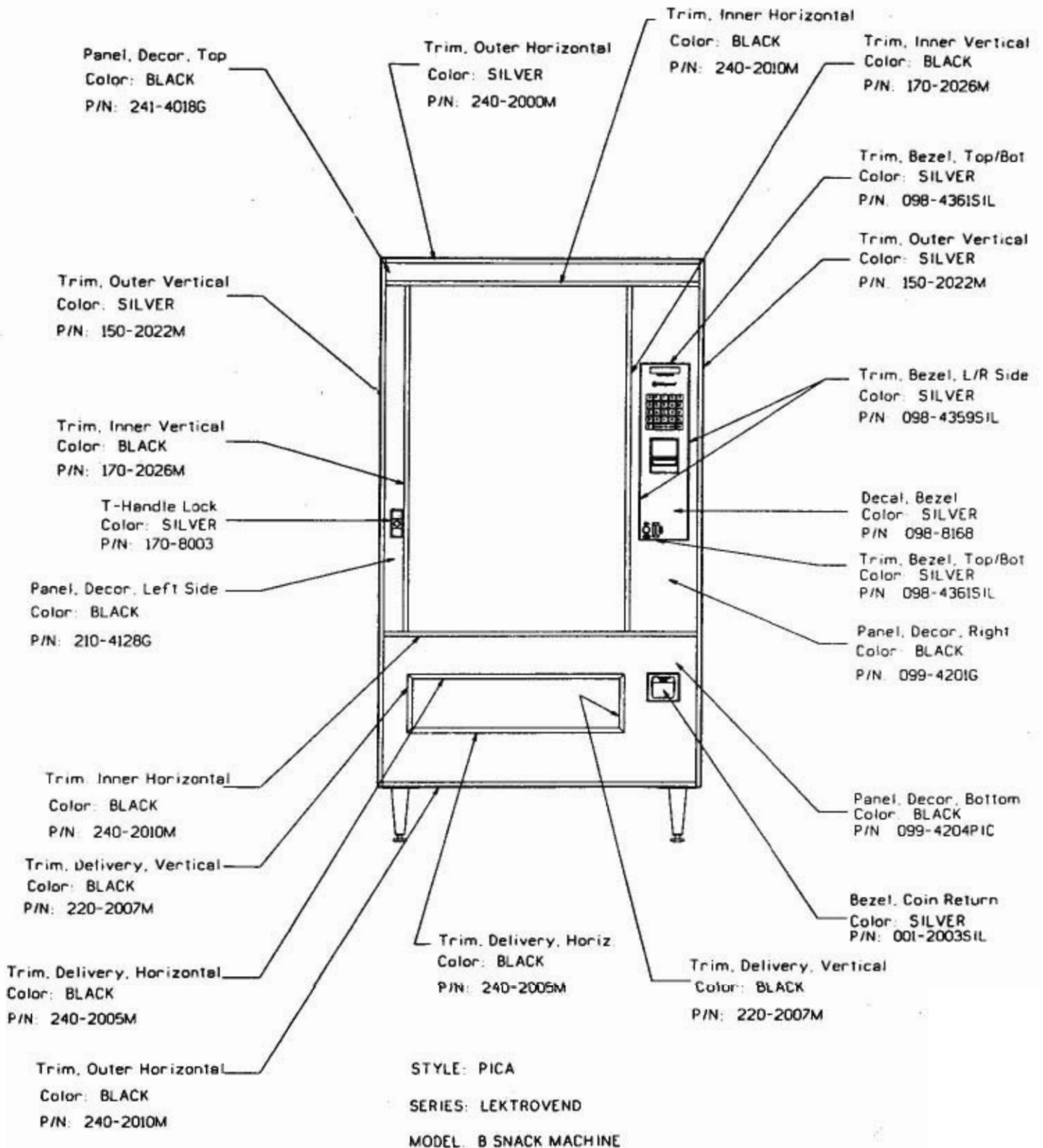

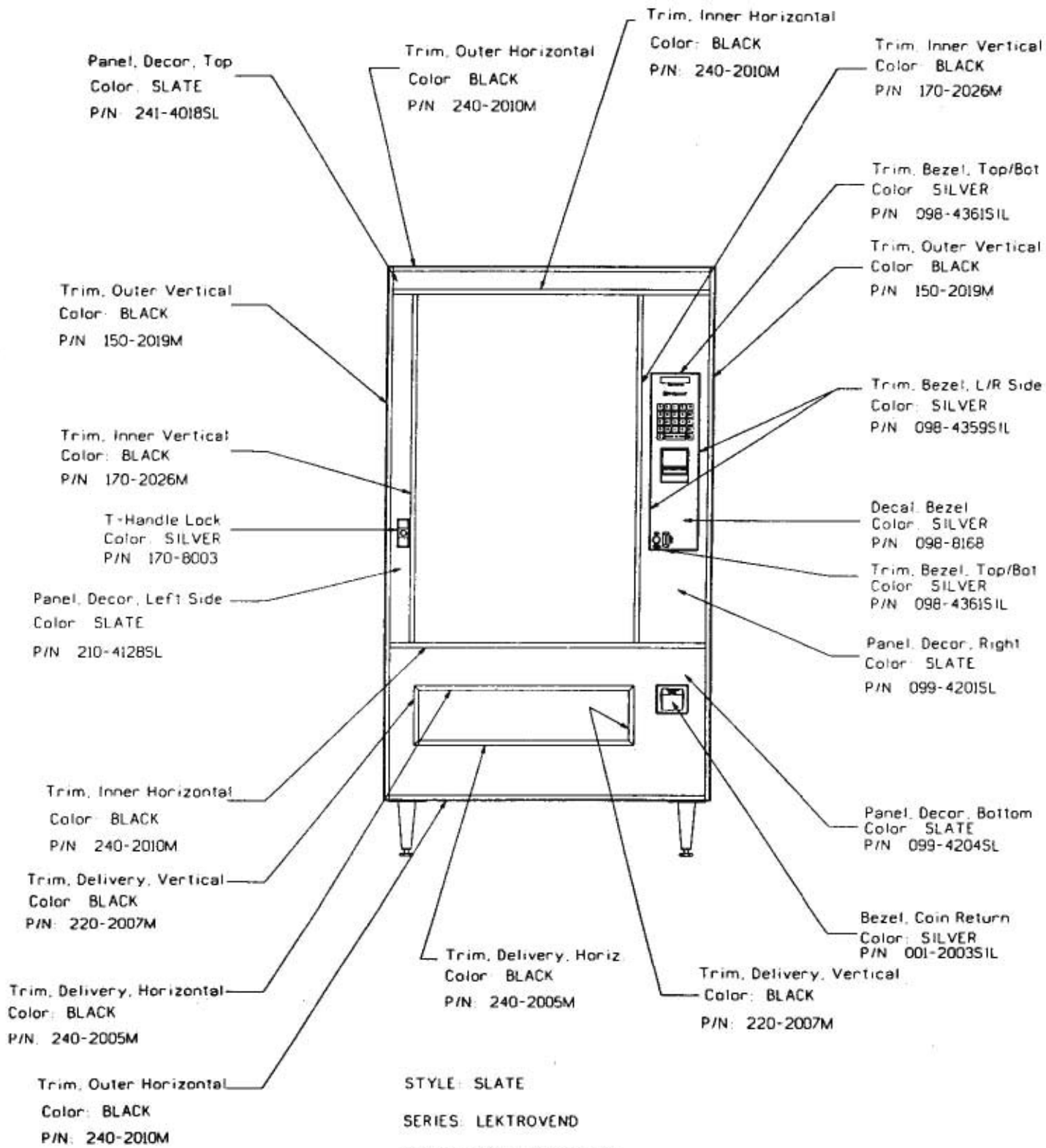

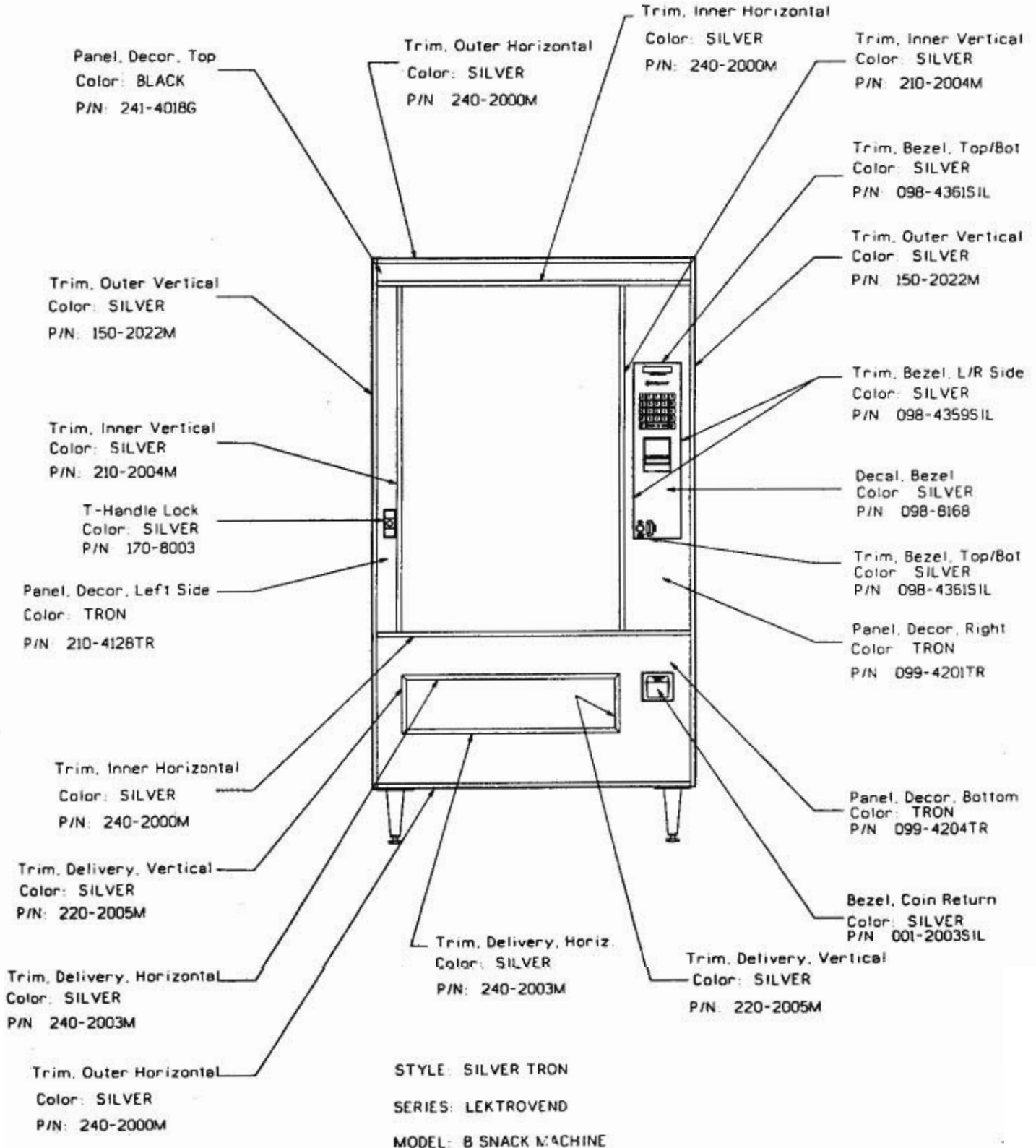

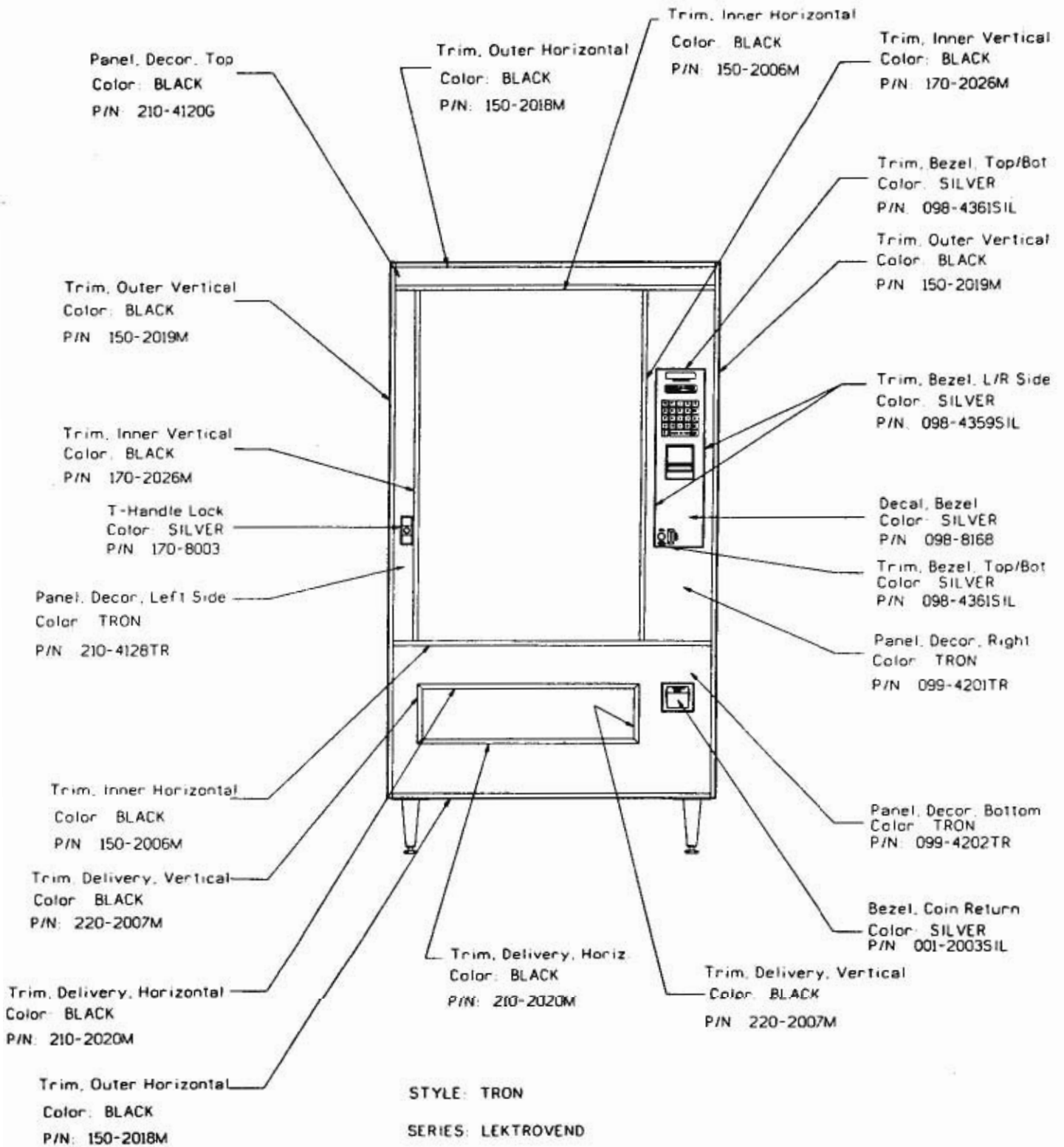

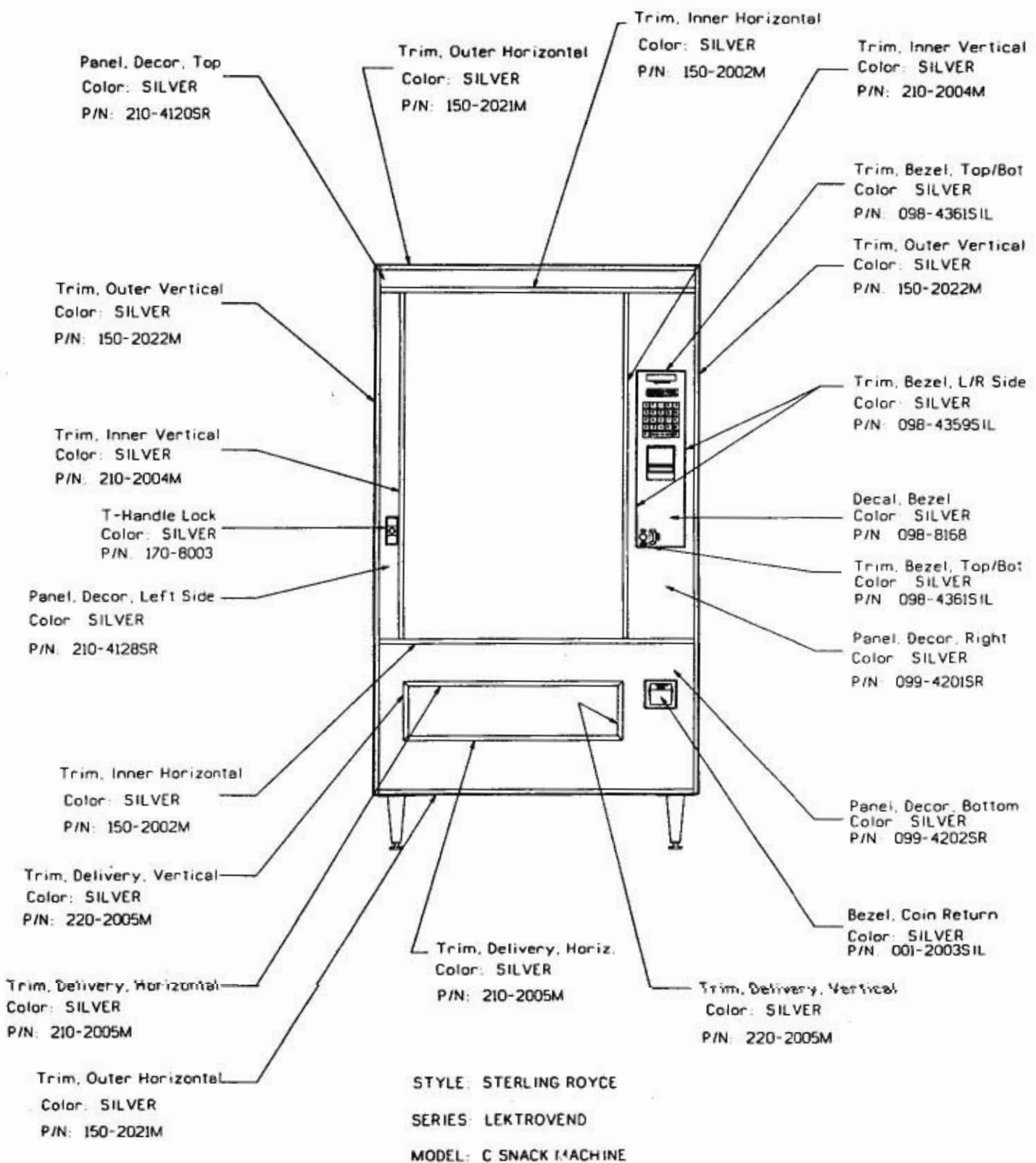

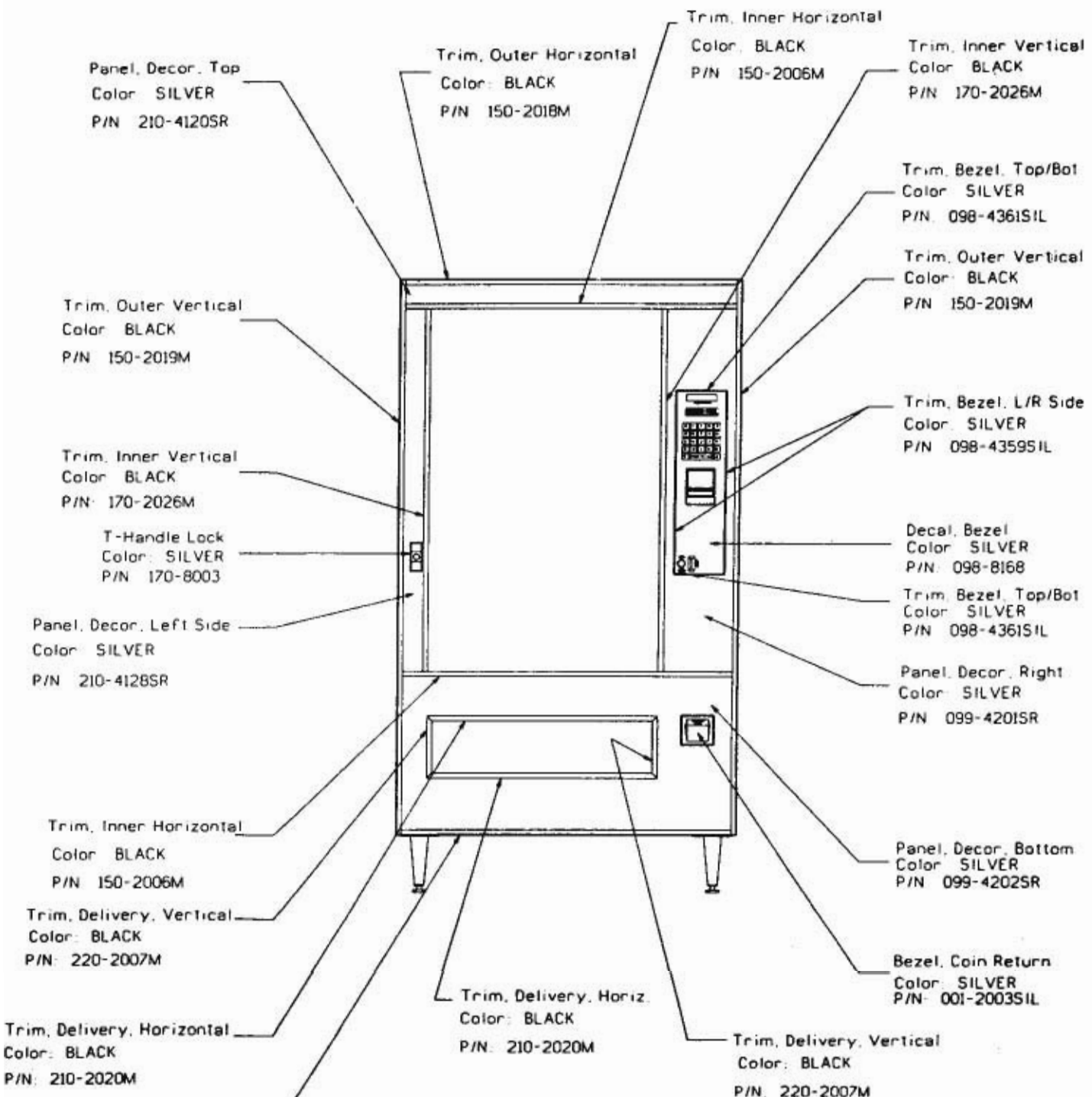

STYLE: SIGNATURE
 SERIES: LEKTROVEND
 MODEL: C SNACK MACHINE

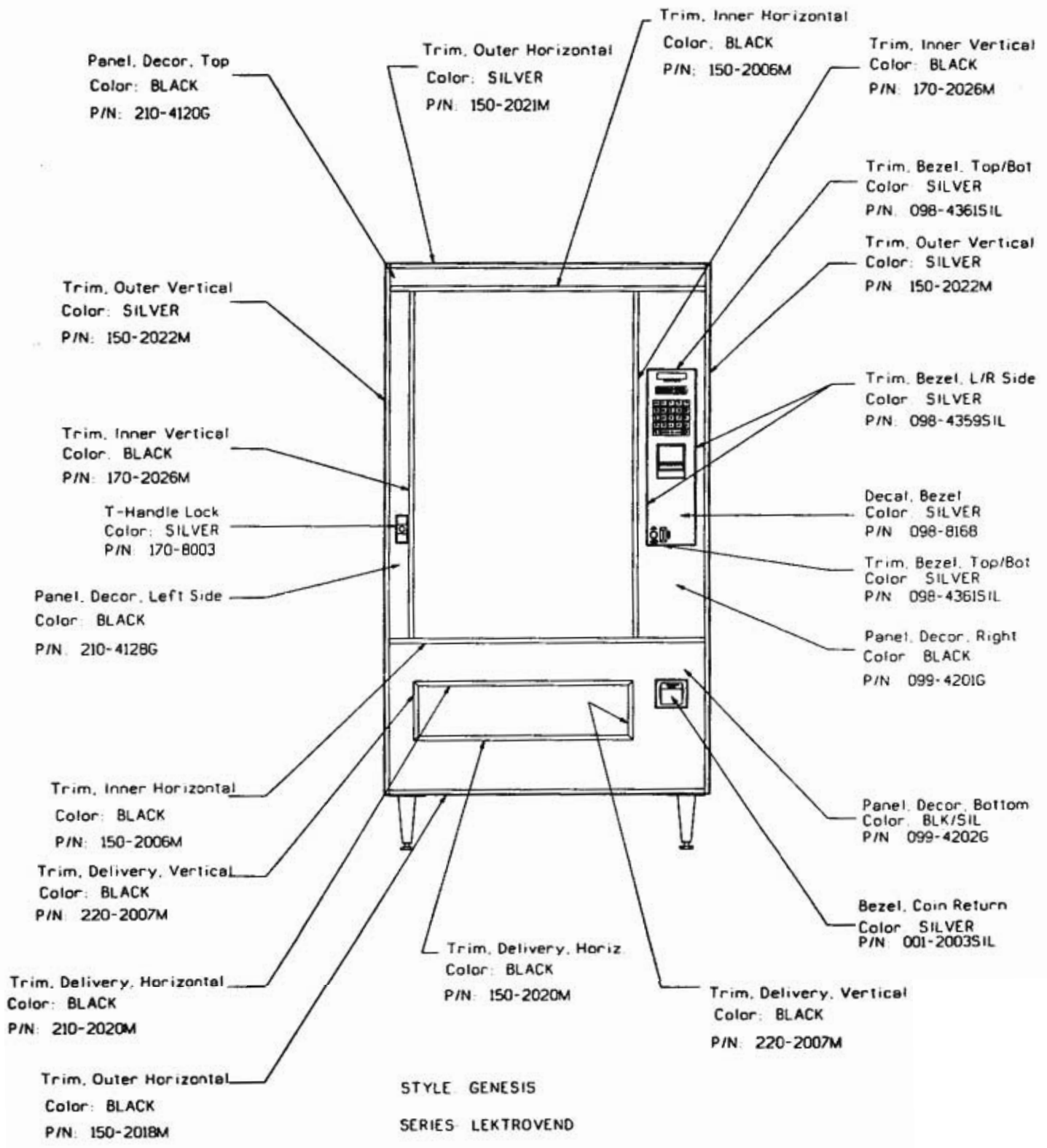

STYLE: GENESIS
 SERIES: LEKTROVEND
 MODEL: C SNACK MACHINE

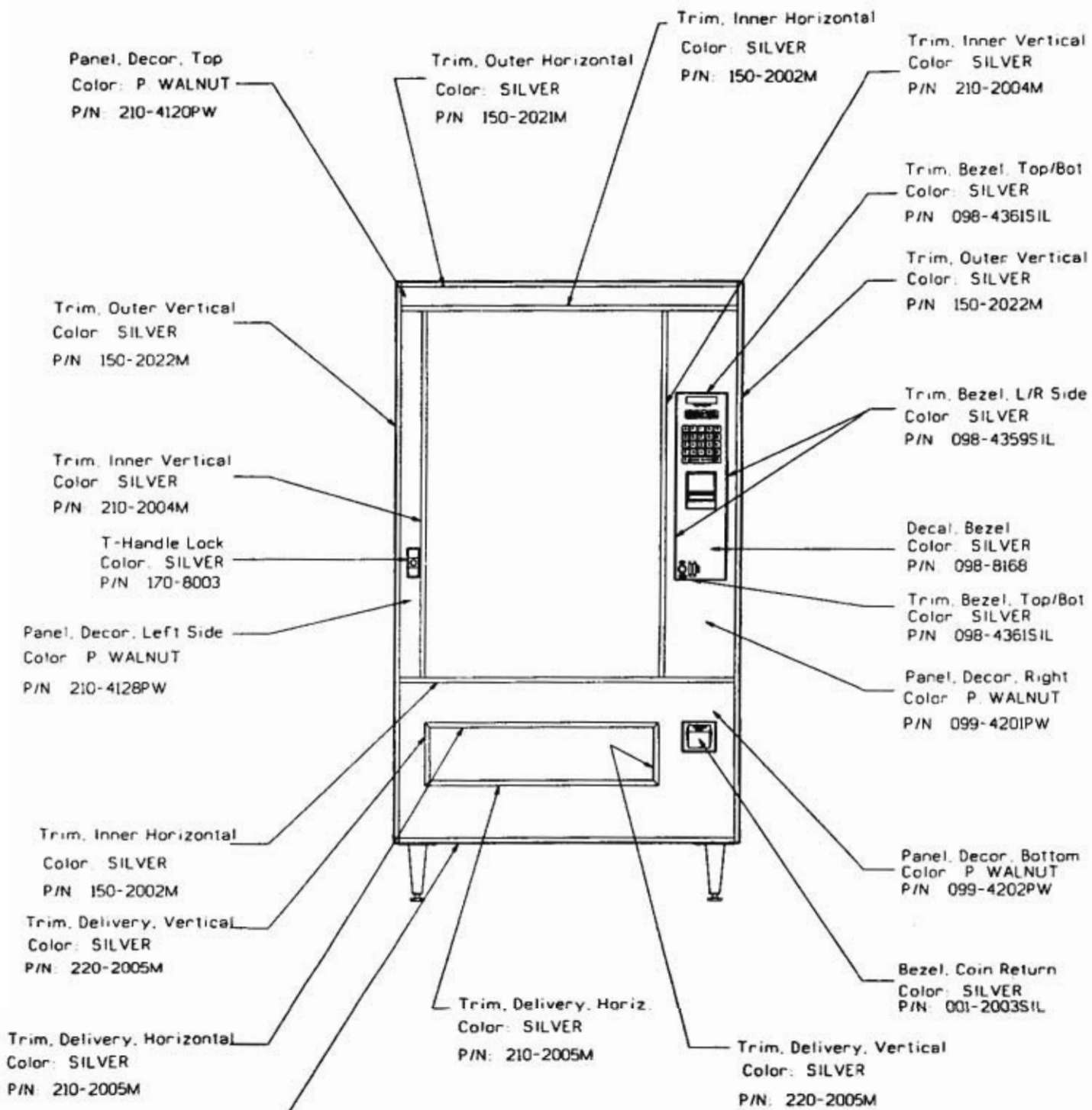

STYLE: PRESIDENTIAL WALNUT
 SERIES: LEKTROVEND
 MODEL: C SNACK MACHINE

