

## Flash Diagnostic Codes

The EX3000 Bill Acceptor has two LEDs that are located on the bezel (**Coin Resistant Style Bezel units only**). The bezel lights aid in determining the status of the bill acceptor. Below is a chart that lists all the flash codes of the EX3000 Bill Acceptor and a description of each code.

| FLASH CODE      | DESCRIPTION OF CODE   |
|-----------------|---|
| Steady Flashing | Ready To Accept   |
| Rapid Flashing  | Magazine or Cassette Full (Remove Bills)                                  |
| LEDs Off        | No power to unit, unit in Flash Download Mode or unit in Calibration Mode |
| 1               | Not used  |
| 2               | Disabled By Interface   |
| 3               | Configuration Coupon Ready Mode   |
| 4               | Bill Jam (Remove Jammed Bill)   |
| 5               | Lockable Removable Cassette (LRC) Removed                                 |
| 6               | Tamper Detected (unit will reset after 15 minutes)                        |
| 7               | End of Stacker Switch Blocked (Remove Blockage)                           |
| 8               | Bill Held in Unit (No Credit Given)                                       |
| 9               | Needs Cleaning  |
| 10              | Needs Cleaning  |
| RAPID BLINKING  | Cassette Full   |

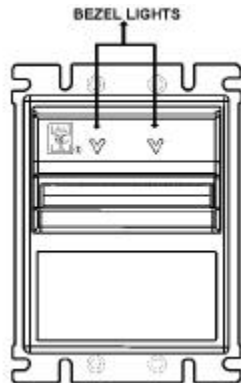

## EX3000 SERIES BILL ACCEPTORS

### INSTALLATION GUIDE

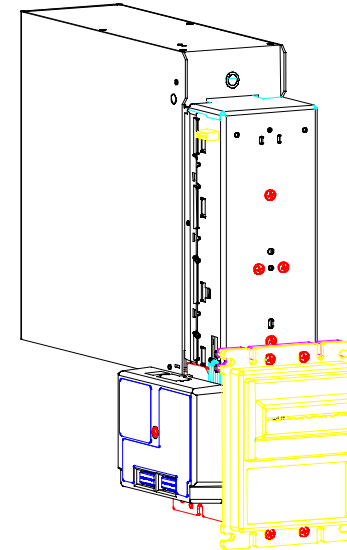

## TABLE OF CONTENTS

|                            |             |
|----------------------------|-------------|
| General information        | Page 3      |
| Option Switches            | Page 4      |
| Setting Option Switches    | Page 5      |
| Mounting the Bill Acceptor | Page 6      |
| Check Operation            | Page 7      |
| Coupon Configuration       | Page 8      |
| Coupon                     | Page 9      |
| Notes                      | Page 10     |
| Calibration                | Page 11     |
| Trouble Shooting Section   | Page 12     |
| Dimensions                 | Page 13     |
| Connector Information      | Page 14, 15 |
| Flash Diagnostic Codes     | Page 16     |

## CONNECTOR INFORMATION

### 18-Pin Mating Connector

AMP "MODU" 18 pin MT Receptacle  
AMP Part #102398-7      IDC Connector Housing  
AMP Part #102536-7      Back Cover  
AMP Part #102681-4      Latching Front Cover  
#22 or 24 Gauge wire recommended

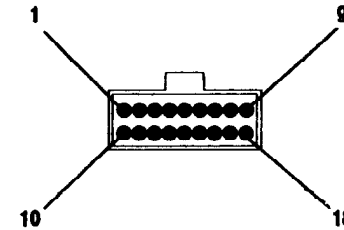

Figure 12.  
18 Pin Interface Connector

### 9-Pin Mating Connector

AMP "MATE-N-LOCK" 9 pin plug  
AMP Part #172161-1      Shell  
AMP Part #170364-1      Male Pin  
#22 Gauge wire recommended

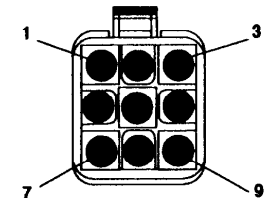

Figure 13.  
9 Pin Power Connector

### 2-Pin Mating Connector

AMP Part #770342 -1      Shell  
AMP Part #640392 -1      Male Pin  
#22 Gauge wire recommended

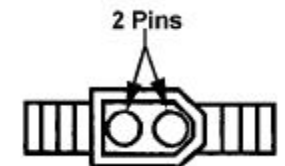

Figure 14.  
2 Pin Connector

## CONNECTOR INFORMATION

### Serial Interface

**NOTE: Bold type indicates those connections required for Serial Interface to operate.**

#### Pinout of EX3000 18-pin Connector (Figure 12.)

|                     |   |
|---------------------|---|
| Pin 1 Reserved      | Pin 10 Out-of - Service                                     |
| Pin 2 Reserved      | Pin 11 <b>Serial Data Output</b>                            |
| Pin 3 Reserved      | Pin 12 Reserved   |
| Pin 4 <b>Ground</b> | Pin 13 Out-of-Service LED Power Source<br>(200 ohm to 5VDC) |
| Pin 5 Reserved      | Pin 14 Reserved   |
| Pin 6 Reserved      | Pin 15 Reserved   |
| Pin 7 Reserved      | Pin 16 <b>Serial Data Receive</b>                           |
| Pin 8 Reserved      | Pin 17 Calibrate (Connect to GND)                           |
| Pin 9 Reserved      | Pin 18 Reserved   |

#### Pinout of EX3000 9-pin Connector (Figure 13.)

##### 115VAC Model

|       |                                |
|-------|--------------------------------|
| Pin 1 | Reserved                       |
| Pin 2 | <b>Heater - 115VAC Hot</b>     |
| Pin 3 | <b>Heater - 115VAC Neutral</b> |
| Pin 4 | <b>115VAC HOT (Power)</b>      |
| Pin 5 | Reserved                       |
| Pin 6 | <b>115VAC Neutral (Power)</b>  |
| Pin 7 | Reserved                       |
| Pin 8 | Reserved                       |
| Pin 9 | Reserved                       |

##### 24VAC Model

|                               |
|-------------------------------|
| <b>Heater - 24VAC</b>         |
| Reserved                      |
| <b>Heater - 24VAC Neutral</b> |
| Reserved                      |
| <b>24VAC HOT (Power)</b>      |
| <b>24VAC Neutral (Power)</b>  |
| Reserved                      |
| Reserved                      |
| Reserved                      |

#### Pinout of EX3000 2-pin Connector (Figure 14).

This optional connector is not biased and may be wired either way to detect the presence of the LRC.

## GENERAL INFORMATION

The Mars Electronics EX3000 Series Bill Acceptors are designed for use in gasoline and unattended outdoor sales applications. The EX3000 is designed to be used with a 600 or 1200 bill Lockable Removable Cassette (LRC).

### Power Requirements

65 Watts at  
115 VAC, 60 Hz or  
24 VAC, 60Hz  
Optional 33 Watt Heater,

### Features

- High security against tampering and fraudulent bills.
- Enhanced acceptance of quality bills.
- One, two or four way bill acceptance.
- Lockable Removable Cassette (LRC) for increased security during cash handling.
- Uses Bi -Directional Serial Interfaces(BDS).
- Optional escrow of last bill with Bi - Directional Serial Interface.
- Optional Heater for extremely cold environments.
- Power supply is protected from rain and condensation.
- Optic components are sealed against contaminants.
- Gears are permanently lubricated and sealed from dirt and moisture.
- Fast transport of bill.
- Flash download software memory upgrades.
- Uses Coupon Configuration.
- Extended Temperature Operating Range

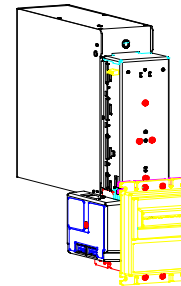

Figure 1.  
EX3000 Bill Acceptor

## OPTION SWITCHES

The EX3000 Bill Acceptor has two banks of switches. Reference Figure 2 below for descriptions of switch settings for the EX3000. To enable bill acceptance, move the appropriate switch on Switch Bank 1 to the **ON** position.

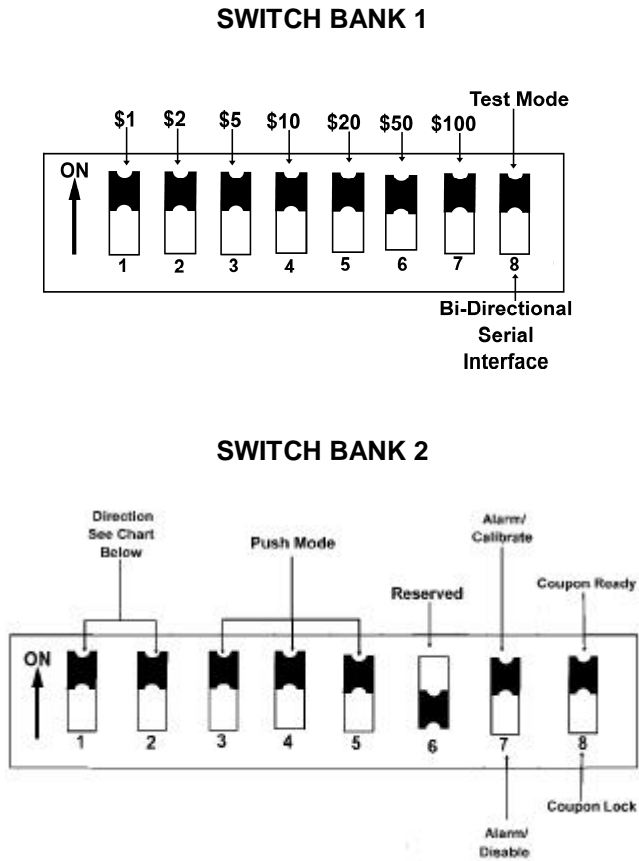

Figure 2. EX3000 Option Switches

| Bill Direction | 1 WAY | 2 WAY | 4 WAY |
|----------------|-------|-------|-------|
| SWITCH 1       | ON    | OFF   | ON    |
| SWITCH 2       | OFF   | ON    | ON    |

## DIMENSIONS

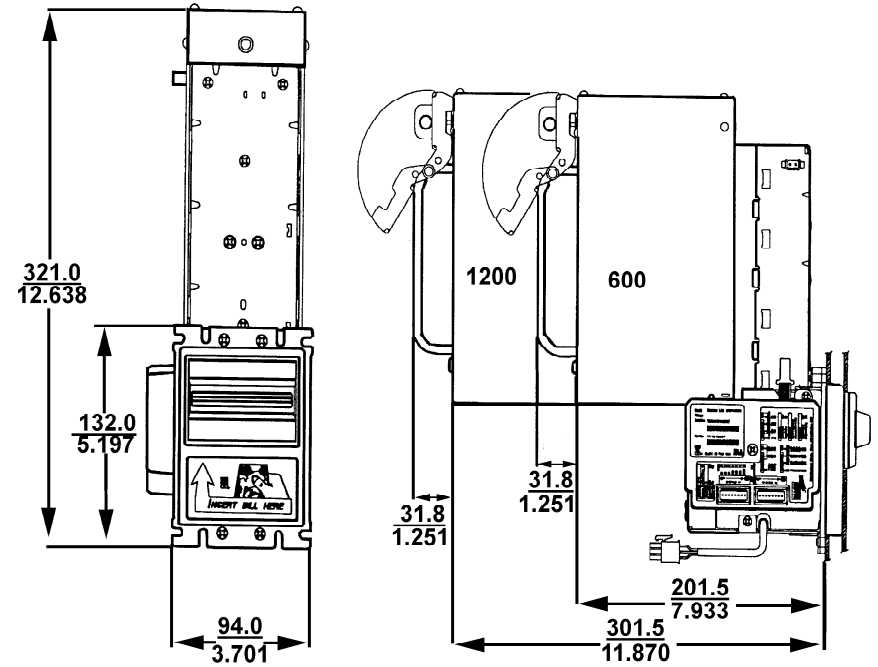

Figure 11. Dimensions for LRC Units, Front and Side View

## TROUBLE SHOOTING SECTION

| EX3000 CHECK LIST   |   |  |
|---|---|--|
| If a problem occurs   | Possible cause  | Please check the following   |
| <b>Acceptor does not run and stack when power is applied.</b> | Unit is not getting power.                                | Check the voltage being supplied to the unit.  |
|   | Unit in calibration mode.                                 | Insure that DIP switch 7 on bank 2 is OFF on power up.   |
| <b>Acceptor does not give credit for bills accepted.</b>      | The acceptor is in "test/pulse" mode.                     | Insure that DIP switch 8 on bank 1 is OFF and cycle power.   |
| <b>Acceptor won't pull in a bill (motor does not start).</b>  | There is no cassette (LRC) present.                       | Install a cassette (LRC).  |
|   | The cassette (LRC) is installed incorrectly.              | Insure that a cassette (LRC) is mounted correctly with the knob turned completely to the install position and not beyond.  |
|   | Unit is disabled by control system.                       | Ensure that the Acceptor is enabled by the control system.   |
| <b>Acceptor has excessive bill jams.</b>                      | The tab of the acceptor is bent.                          | The tab that a cassette locks onto should be in line (flat) with respect to the top of the stacker housing. If it is bent (up or down), bend it back until it is flat. |
|   | The cassette (LRC) is installed incorrectly.              | Insure that a cassette (LRC) is mounted correctly with the knob turned completely to the install position and not beyond.  |
| <b>Acceptor rejects all bills.</b>                            | The acceptor has had a failure of one or more components. | Replace Acceptor.  |
|   | The acceptor is out of calibration.                       | Calibrate the Acceptor.  |

## SETTING OPTION SWITCHES

- Option switches are shown on the side of the unit (**See Figure 3**).
- Set the switches with a small screw driver or equivalent device.  
**DO NOT USE A GRAPHITE PENCIL POINT.**

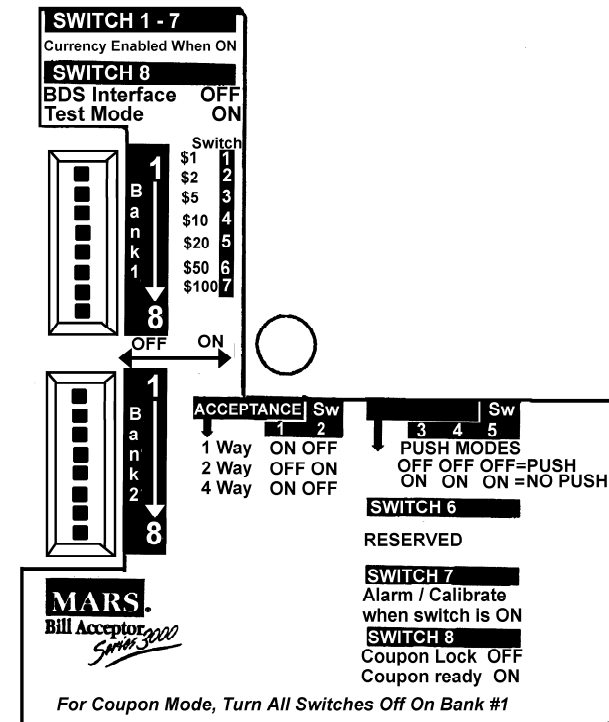

Figure 3. Setting The Option Switches

## MOUNTING THE BILL ACCEPTOR

### NOTE: REMOVE POWER BEFORE MOUNTING THE BILL ACCEPTOR

1. Connect the power harness to the 9 pin power connector of the Bill Acceptor (Figure 4). Connect the 18 pin connector of the interface harness to the 18 pin connector socket on the control board (Figure 4). Connect the 2 pin cassette present harness (if applicable) to the cassette present connector (Figure 4).

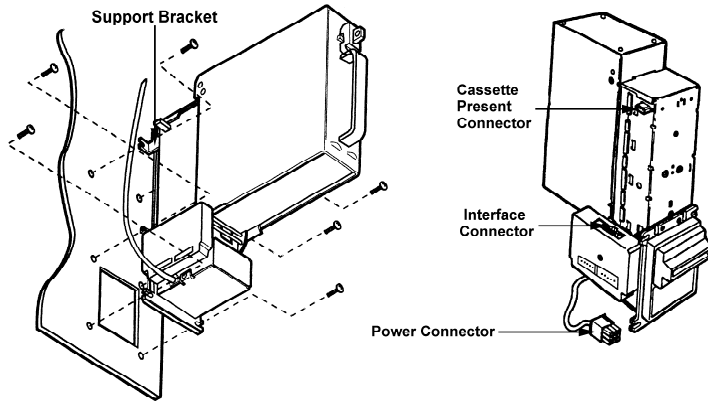

Figure 4. Mounting / Harness Connections  
*Shown With Optional LRC12*

2. It is recommended to use a *Support Bracket* (kit # 111638145) for the stacker housing when using any cassette larger than 600 bills, see figure 4.
3. Line up the Bezel Mounting Screw Holes with the Mounting Screw Holes and install 4 Mounting Screws. Follow the same procedure for mounting the optional Support Bracket and install 2 Bezel Screws.
4. With one end of the harness connected to the Bill Acceptor, route the harness through the machine and make the necessary connections. Dress all harness wires to avoid interference with equipment operation.

## CALIBRATION

### REMOVE POWER BEFORE PERFORMING THE FOLLOWING PROCEDURE

NOTE: MEI Kit # 111636021 required for calibration.

1. Unplug both the power (9 pin) and interface (18 pin) connectors from the unit.
2. Move DIP switch # 7 (Bank 2) to the **ON** position. (MEI does not recommend calibrating the Acceptor in direct sunlight)
3. Connect the calibration jumper plug to the interface connector (18 pin) on the control board.
4. Reconnect the power connector (9 pin). The red bezel lights will illuminate, but the acceptor will not reset (run and stack) until the calibration is complete.
5. Insert a piece of hole-punched or date stamped calibration paper into the mouth of the bill acceptor. The hole or date stamp (face up or face down) should be at the trailing edge of the insertion. The bill acceptor will pull the calibration paper into the unit in segments. After a pause, the calibration paper will be rejected by the bill acceptor, remove calibration paper and the stacker push plate will cycle indicating a successful calibration.  
**NOTES:** Should the stacker push plate fail to cycle, remove power and repeat Steps 5. Do not use bent, scratched, or dirty calibration paper.
6. After the unit has been calibrated, turn DIP switch # 7 (Bank 2) to its original position.
7. Test bill acceptance with the calibration jumper plug (Test Mode). The calibration jumper plug automatically enables test mode. When the Bill Acceptor is in test mode, the unit may be tested without altering the site accounting.
8. After bill acceptance has been tested, remove the calibrations plug. Insert 18 pin connector and cycle power to the bill acceptor (restart the bill acceptor).

---

## NOTES

---

---

## CHECK OPERATION

---

### REMOVE POWER BEFORE PERFORMING CHECKOUT PROCEDURE

Verify proper operation using instructions as provided by the equipment manufacturer.

Bill Acceptance may be tested without interfering with site accounting by using the following steps:

1. Disconnect the power harnesses from the 9 pin and the 18 pin connectors.
2. Set all DIP switches (Bank 1) to the **ON** position.
3. Connect the power harness to the 9 pin connector and apply power.
4. Verify stacker actuation and bill acceptance.
5. **REMOVE POWER**, then disconnect the power harness from the 9 pin connector.
6. Return the option switches to their original settings.
7. Connect the power harnesses to the 9 pin and the 18 pin connectors.
8. Apply power and procedure with normal operational tests.

---

## COUPON CONFIGURATION

---

### COUPON CONFIGURATION

1. **Make copies of the coupon with a standard copier.** Copies of the coupon are usable if cut to match the size of the attached coupon.
2. Fill out the coupon using a #2 pencil to fill in the blocks for desired options. For correct operation, all 8 lines must be completed. Fill in only one block per line. **Do not mark the back of the coupon.**
3. Complete lines 1 thru 7 to enable desired bill denominations. Fill in one block for each denomination. High Accept enables maximum bill acceptance. High security may be desired for locations where a higher level of discrimination is desired. Off will reject bills of the selected denomination.
4. Complete line 8 to enable desired bill direction. Enable 1 or 2 way face up, or 4 way acceptance (which allows acceptance in all directions).

### TO ENABLE THE COUPON CONFIGURATION MODE

1. Turn DIP switches #1 thru 7 (switch bank 1) to the **OFF** position. Turn DIP Switch #8 (switch bank 1) **ON** if the 18 pin interface harness is disconnected.
2. To enter the coupon mode turn DIP switch # 8 (switch bank 2) to the **ON** position and cycle power. The bill acceptor will give a flash code of 3, when this occurs insert the coupon into the bill acceptor. After using the coupon return DIP switches #8 to their original position.

### INSERT COUPON AND VERIFY SETTINGS WERE ACCEPTED

**ACCEPTED:** If the coupon is accepted, it will be hold in escrow mode for about 3 seconds then returned.

**REJECTED:** If the coupon is rejected, it will be immediately returned. If rejected, review instructions or try new coupon.

---

## COUPON CONFIGURATION

---

**" USE COPIES ONLY"**