

Snack Center 1

147/148

MECHANICAL SET-UP, OPERATION and MAINTENANCE MANUAL

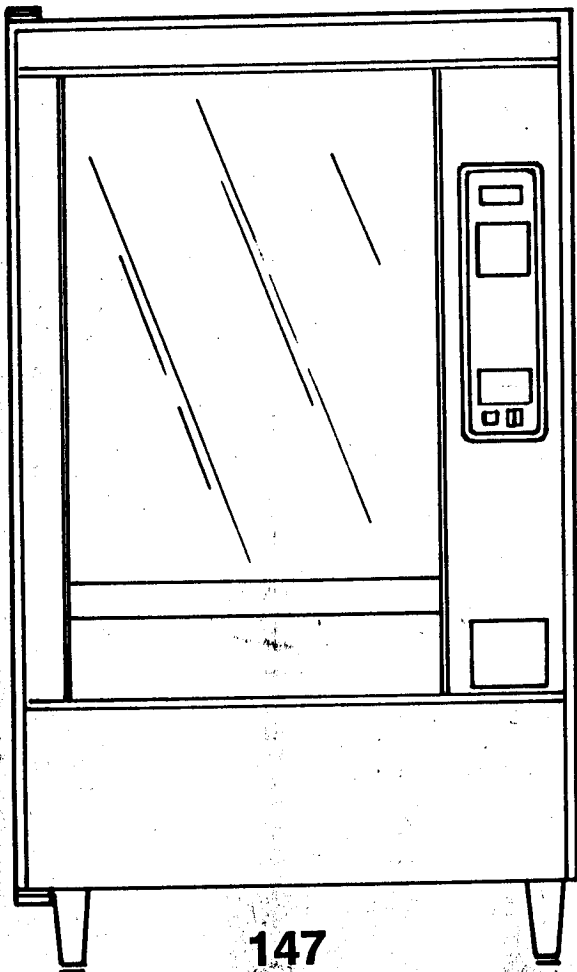

147

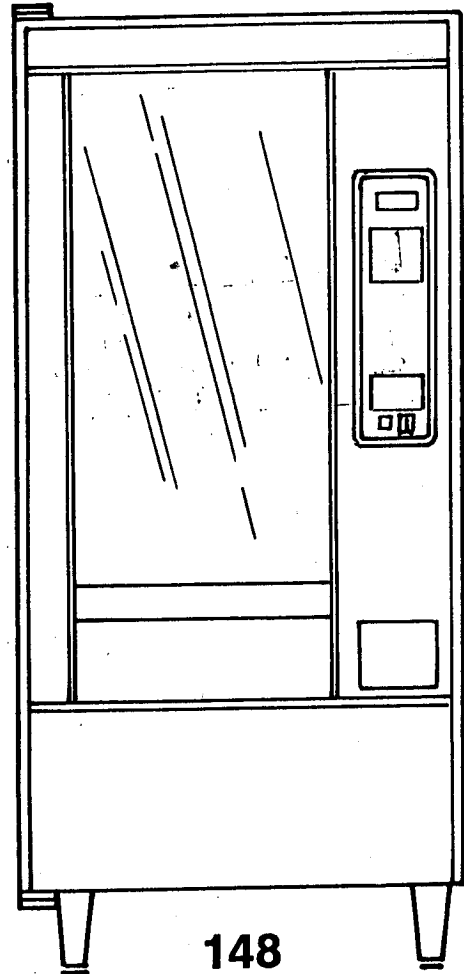

148



CRANE-NATIONAL VENDORS

12955 ENTERPRISE WAY
BRIDGETON, MO 63044



TABLE OF CONTENTS

SNACK CENTER Warranty	ii
Maintenance and Certifications	ii
Table of Contents	iii
MERCHANDISER INSTALLATION PROCEDURES	1
Location and Identification of Major Assemblies	2
Electrical Requirements	4
Moving Merchandiser Through A Narrow Doorway	5
Positioning and Leveling the Merchandiser	7
Installing the Optional Base Plate	8
Turning the Merchandiser ON and OFF	10
MECHANICAL SET-UP PROCEDURES	11
Coin Mechanism Set-Up	12
Tray Set-Up Overview	13
Placing Tray In Loading Position	14
Adjusting Tray to Accommodate Wider Products	15
Removing A Tray From the Merchandiser	16
Removing A Column Divider	17
Changing A Spiral	18
Removing A Spiral Coupler	20
Installing A Spiral Bearing	21
Installing A Gear	22
Installing A Spiral Coupler	23
Returning A Tray To the Merchandiser	24
Disconnecting and Connecting A Motor Harness	25
Installing A Spiral Motor	26
Adjusting Merchandiser To Vend Taller Products	27
Installing, Adjusting and Removing Product Spacers	31
Loading A Tray With Product	32
Returning A Tray To the Vending Position	33
Installing And Adjusting Price Labels	34
Installing Selection ID Labels	36
Gum & Mint Dispenser Overview	38
Putting Gum & Mint Dispenser In Loading Position	39
Removing and Installing Column Reducers	40
Loading Gum & Mint Dispenser With Product	41
Returning Gum & Mint Dispenser To Vending Position	42
Attaching Product Price Labels	43
OPERATIONAL READINESS CHECKING PROCEDURES	45
Operational Readiness Check Overview	46
Anti Hang-Up Procedure Overview	47
Indexing 1 Spiral Used With A Right Hand Motor	48
Indexing 1 Spiral Used With A Left Hand Motor	49
Indexing 2 Spirals Used With 1 Motor	50
Indexing 2 Spirals Used With 2 Motors	51
Installing A Product Pusher	52
Installing and Removing A Spiral Wall Retainer	53
Retrieving A Product Through the Delivery Door	54
Testing the Bill Validator	55

TABLE OF CONTENTS
(Continued)

ROUTINE SERVICE AND MAINTENANCE PROCEDURES	57
Removing and Replacing the 3/4 amp fuse	58
Installing the Optional Cash Box Lock	59
Removal and Replacement of the Cash Box	60
Replacing the Fluorescent Lamp Starter	60
Replacing the Fluorescent Lamp	61
Installing the Optional Exhaust Fan	62
Lubrication	64
Cleaning the Merchandiser	64
Wiring Diagram - SNACK CENTER 1	65
Schematic Diagram - SNACK CENTER 1	66

NOTE

THE INSTRUCTIONS FOR INSTALLING AND OPERATING
THIS MERCHANDISER ARE CONTAINED IN THE FOLLOWING
MANUALS:

Mechanical Set-Up, Operation and Maintenance Manual

Programming Guide

The information in this part of the manual has been provided to help you install the merchandiser on location.

INSTALLATION OF THE MERCHANDISER

- I-1 Location and Identification of Major Assemblies
- I-2 Electrical Requirements
- I-3 Moving Merchandiser Through A Narrow Doorway
- I-4 Positioning and Leveling the Merchandiser
- I-5 Installing the Optional Base Plate
- I-6 Turning the Merchandiser ON and OFF

I-1 Identification and Location of Major Assemblies and Components

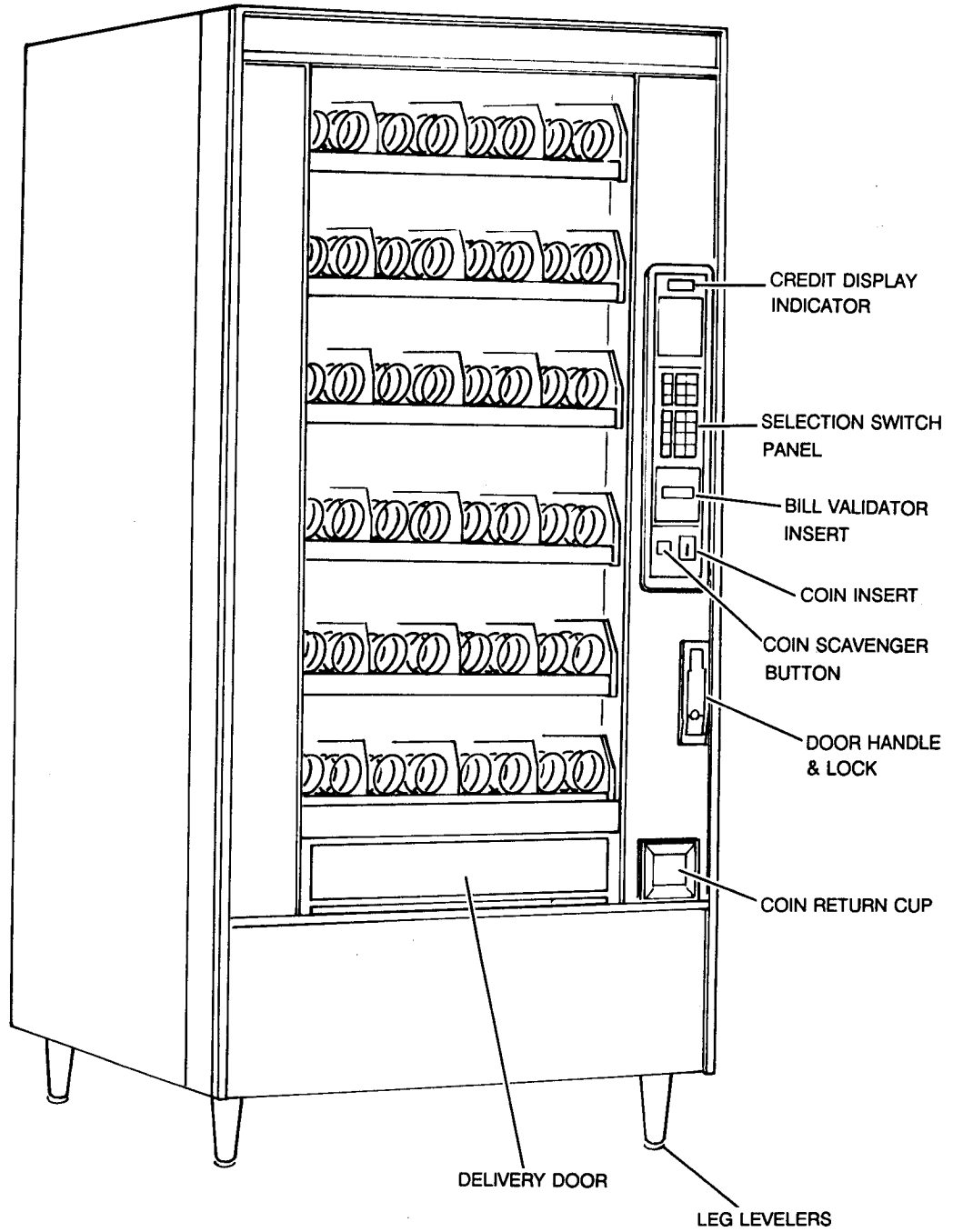

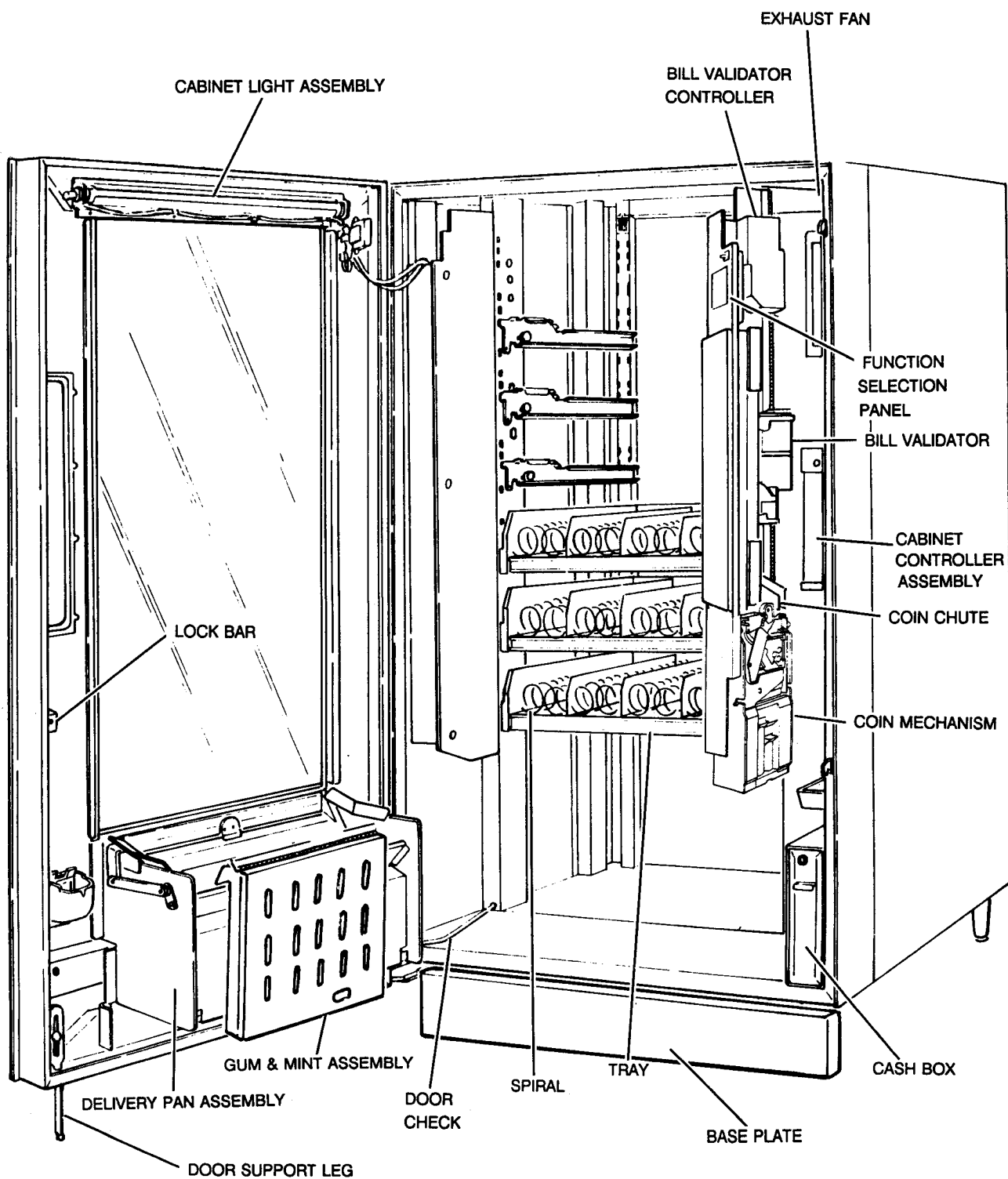

ELECTRICAL SERVICE

*** Power Outlet Requirements**

- 120 volts; not less than 110 volts at peak usage time
- 60 Hz
- Single phase
- 3 amp
- 3-pin, grounded type outlet

NOTE

THE WARRANTY ON THIS MERCHANDISER
IS NULL AND VOID WHEN THE ELECTRICAL
REQUIREMENTS LISTED ABOVE ARE NOT MET.

*** Voltage Check**

- When placed across the **HOT** and **NEUTRAL** terminals, a volt-ohmmeter should indicate 110-130 volts ac.

*** Polarity Check**

- When placed across the **HOT** and **GROUND** terminals, a volt-ohmmeter should indicate 110-130 volts ac.

*** Noise Potential Check**

- When placed across the **NEUTRAL** and **GROUND** terminals, a volt-ohmmeter should indicate 0 volts ac. A reading of greater than 1.5-2.0 volts ac could result in noise problems for the electronic circuitry.

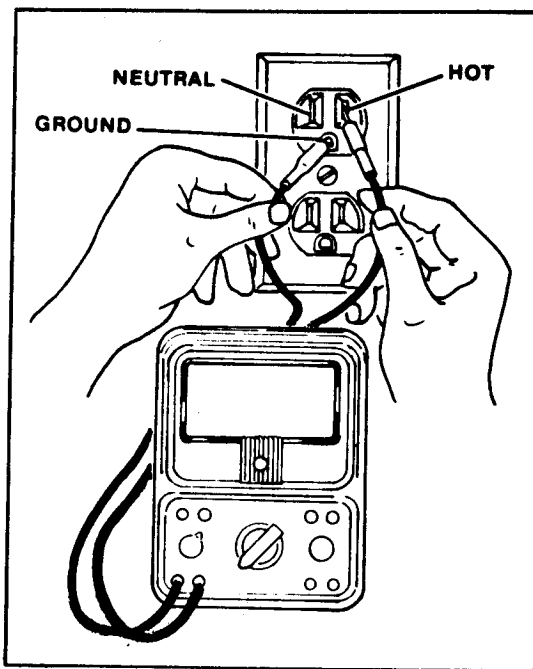

This merchandiser can be moved through an opening as narrow as 30 inches by removing the Cabinet Extensions.

REMOVING THE TOP EXTENSION (Figure -A)

- * Remove the two screws that secure each end of the extension to the sides of the cabinet.
- * Model 147 - Remove the other five screws that secure the extension to the cabinet.
- Model 148 - Remove the other four screws that secure the extension to the cabinet.

- * Pull extension forward to remove it from the merchandiser.

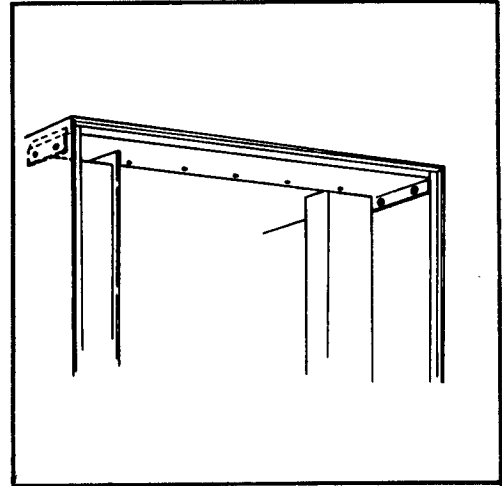

REMOVING THE DOOR CHECK (Figure -B)

- * Remove the nut and bolt that secure the Door Check to the Door Check Plate.
- * Pull the Door Check fully forward, lift upward and pull the short end of the Check from the Door Check Plate and Spring Assembly.

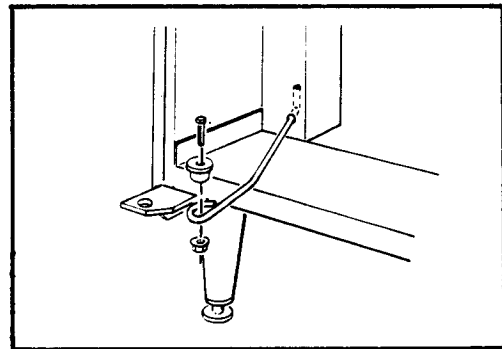

REMOVING THE BOTTOM EXTENSION (Figure -C)

- * Remove the two screws that secure each end of the extension to the sides of the cabinet.
- * Model 147 - Remove the other five screws that secure the extension to the bottom of the cabinet.
- Model 148 - Remove the other four screws that secure the extension to the bottom of the cabinet.

- * Pull the extension forward and remove it from the cabinet.

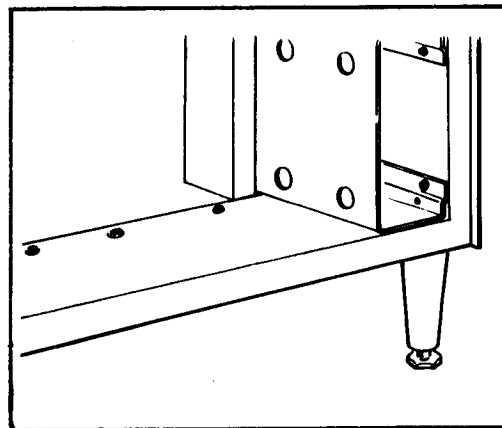

TAKING THE MERCHANDISER THROUGH THE OPENING

- * Open the Cabinet Door and place it square with the left side of the Cabinet.
- * Carefully walk the merchandiser through the opening.

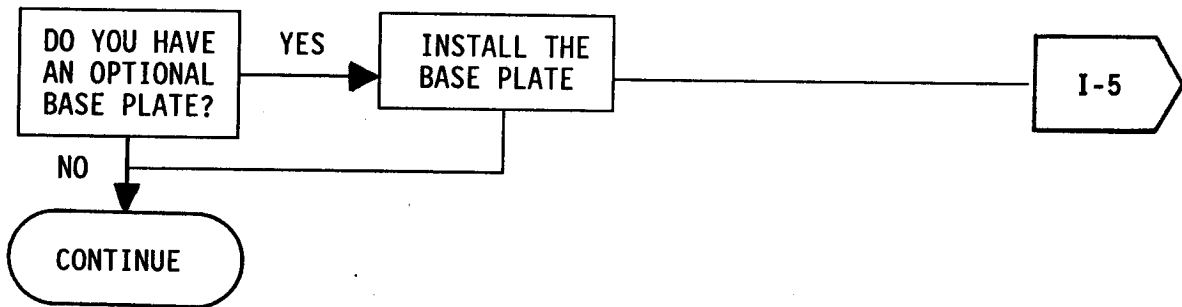
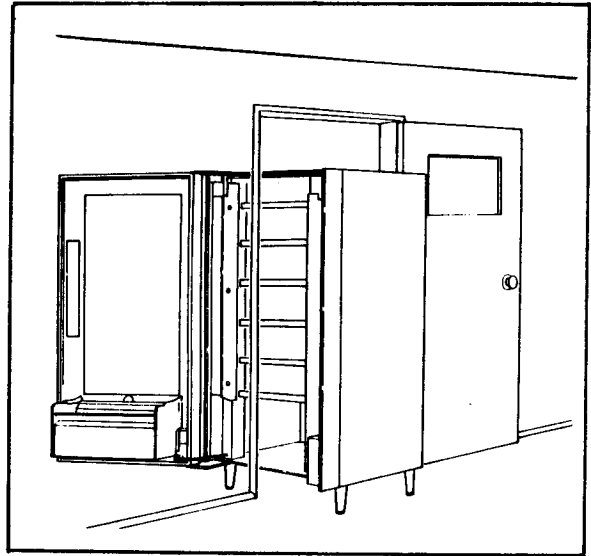

REASSEMBLE THE MERCHANDISER

- * Replace the Upper Extension.
- * Replace the Lower Extension.
- * Replace the Door Check.

POSITIONING THE MERCHANDISER

- * You can position this merchandiser anywhere in a bank of machines. It can even be placed on an end flush against a side wall.
- * To prevent damage to the power cord, the merchandiser should be located at least 1 inch away from the back wall.
- * There should be enough room in front of the merchandiser for the door to move freely. Model 147 requires 39 inches and Model 148 requires 32 inches.

WARNING

This machine is only rated for use in indoor locations.

LEVELING THE MERCHANDISER

IMPORTANT

A level merchandiser is less likely to tip over and cause a personal injury.

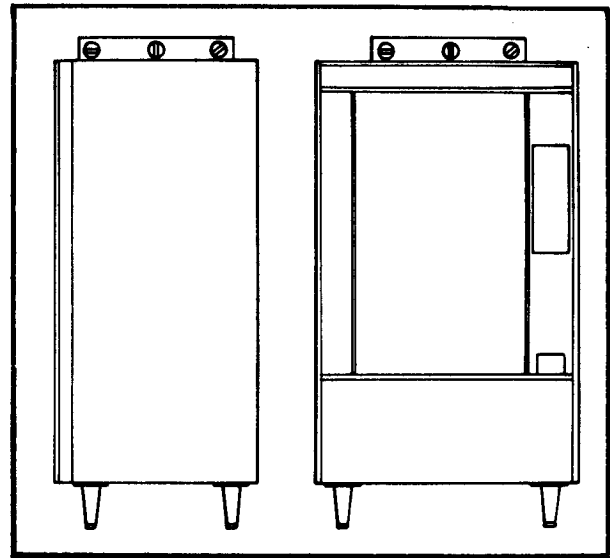

- * Level the merchandiser from right to left and from front to back. Use a spirit level while leveling the merchandiser. See Figure .A.
- * If this merchandiser will be part of a group of machines, it should also be leveled in reference to the other machines.

CAUTION

Have an assistant hold the merchandiser while you adjust the levelers. If the cabinet tips, you may be injured or the merchandiser may be damaged.

- * If the merchandiser is not level, move the Leg Levelers in or out to make it level. See Figure .B.
- * You may need to use pliers or channel locks to loosen the leg leveler.

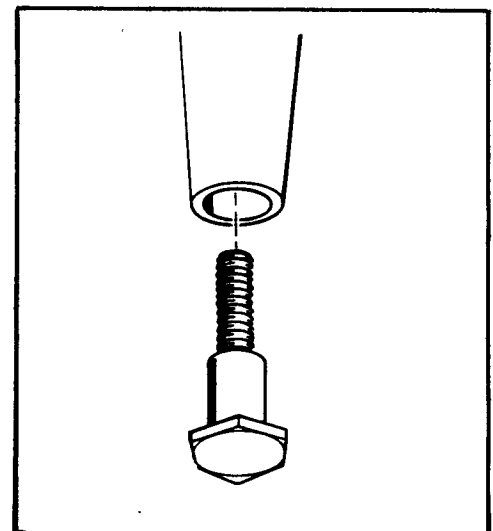

I-5 Mounting The Optional Base Plate

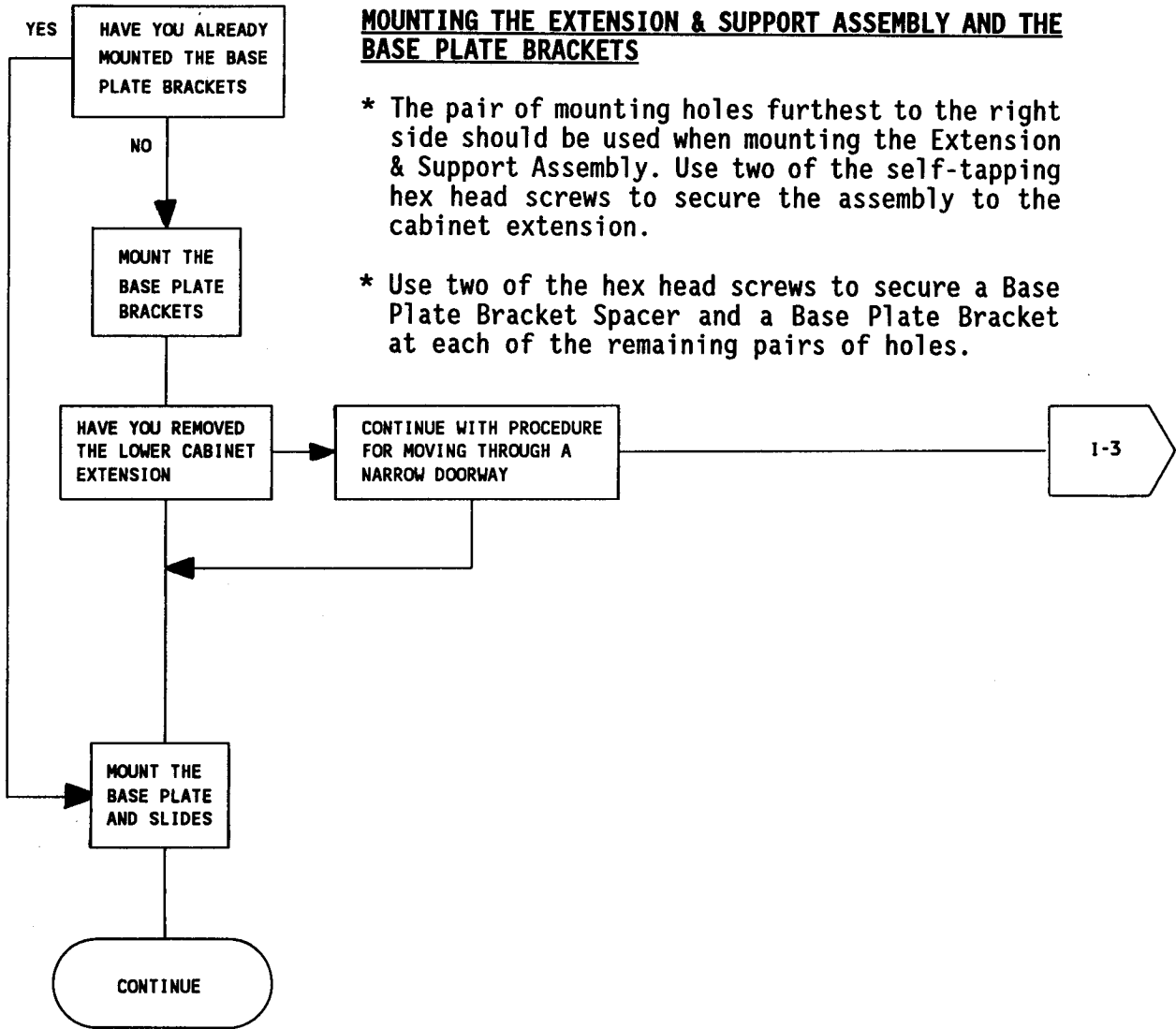

MOUNTING THE BASE PLATE AND SLIDES

- * Insert the short arms of the slides into the hinged tabs of the Base Plate. Position the slide so the notch near the short arm is on the bottom side.
- * Insert the long arms of the slides into the base plate brackets.
- * Insert and secure a cotter pin through the hole in the back end of each of the slides.
- * Push the base plate toward the merchandiser cabinet. The front tab of the base plate bracket should seat in the notch in the long arm of the slide.

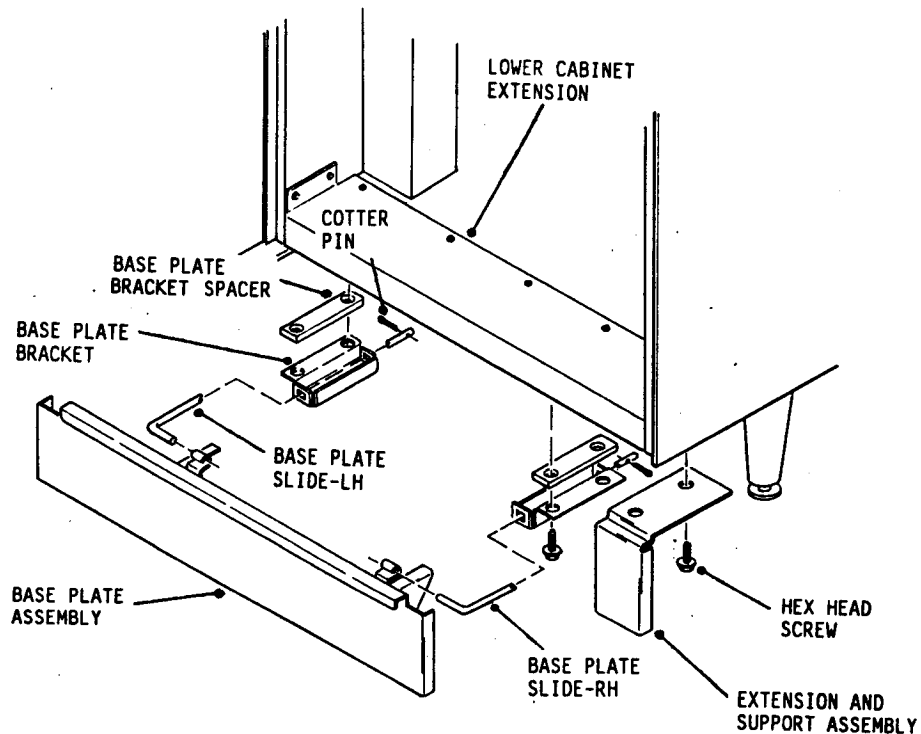

- * Power to the merchandiser is controlled by the Main Power Switch. It is located on the Power Panel.
- * The Power Panel is on the right side of the merchandiser, behind the monetary door.

WARNING

You should unplug the merchandiser whenever you do one of the following:

- Change a fuse
- Change the flourescent lamp
- Change the lamp starter
- Connect or disconnect a harness
(Except a motor harness when the tray has been removed)

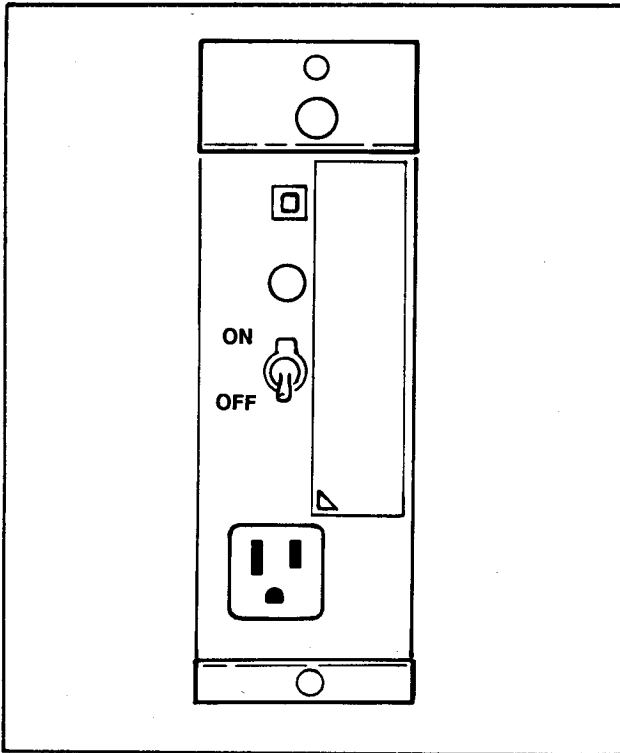

NOTE

The Tray List feature (P4-9) is set at the factory to list the trays that were installed at the time of shipping. If any trays are not locked in place and do not make good electrical contact, the display will alternate between:

ID TRAY - UNLATCHED

when the door is closed. You will hear a beeping sound. This condition will continue for one minute. The normal stand-by message will return to the display at the end of this period of time. You may disable this feature by using procedure P4-9 to remove all trays from the list.

The information in this part of the manual has been provided to help you prepare the merchandiser for vending.

MECHANICAL SET-UP PROCEDURES

COIN MECHANISM SET-UP

TRAY SET-UP

- S-1 Placing Tray In Loading Position
- S-2 Adjusting Tray To Accommodate Wider Products
- S-3 Removing A Tray From the Merchandiser
- S-4 Removing A Column Divider
- S-5 Changing A Spiral
- S-6 Removing A Spiral Coupler
- S-7 Installing A Spiral Bearing
- S-8 Installing A Gear
- S-9 Installing A Spiral Coupler
- S-10 Returning A Tray To the Merchandiser
- S-11 Disconnecting and Connecting A Motor Harness
- S-12 Installing A Spiral Motor
- S-13 Adjusting Merchandiser To Vend Taller Products
- S-14 Installing, Adjusting and Removing Product Spacers
- S-15 Loading A Tray With Product
- S-16 Returning A Tray To the Vending Position
- S-17 Installing and Adjusting Price Labels
- S-18 Installing Selection ID Labels

GUM & MINT DISPENSER SET-UP

- S-30 Putting Gum & Mint Dispenser In Loading Position
- S-31 Removing and Installing Column Reducers
- S-32 Loading Gum & Mint Dispenser With Product
- S-33 Returning Gum & Mint Dispenser To Vending Position
- S-34 Attaching Product Price Labels

- * If the changer is not a MARS TRC 6000, procede to "Loading the Coin Mechanism".
- * If the changer is a MARS TRC 6000, you must set the high quarter switch.

SETTING THE QUARTER SWITCH

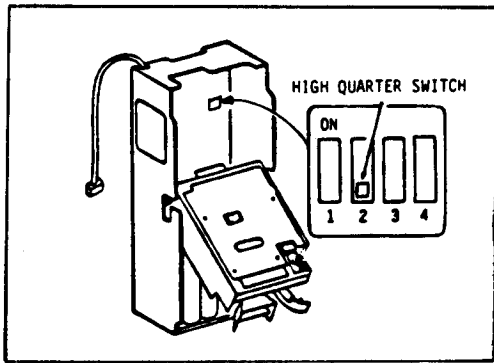

QUARTER SWITCH POSITION	ACTION
LOW	Will accept only one \$1.00 bill.
HIGH	Will accept \$1.00 bills equal in value to first whole dollar above highest vend price.

LOADING THE COIN MECHANISM

- * Open the Cabinet Door.
- * Open the Monetary Door.
- * Insert coins one at a time until each of the coin tubes has been filled.
- * Inspect the tubes for shingled coins and correct if necessary.

MECHANICAL SET-UP OF TRAYS

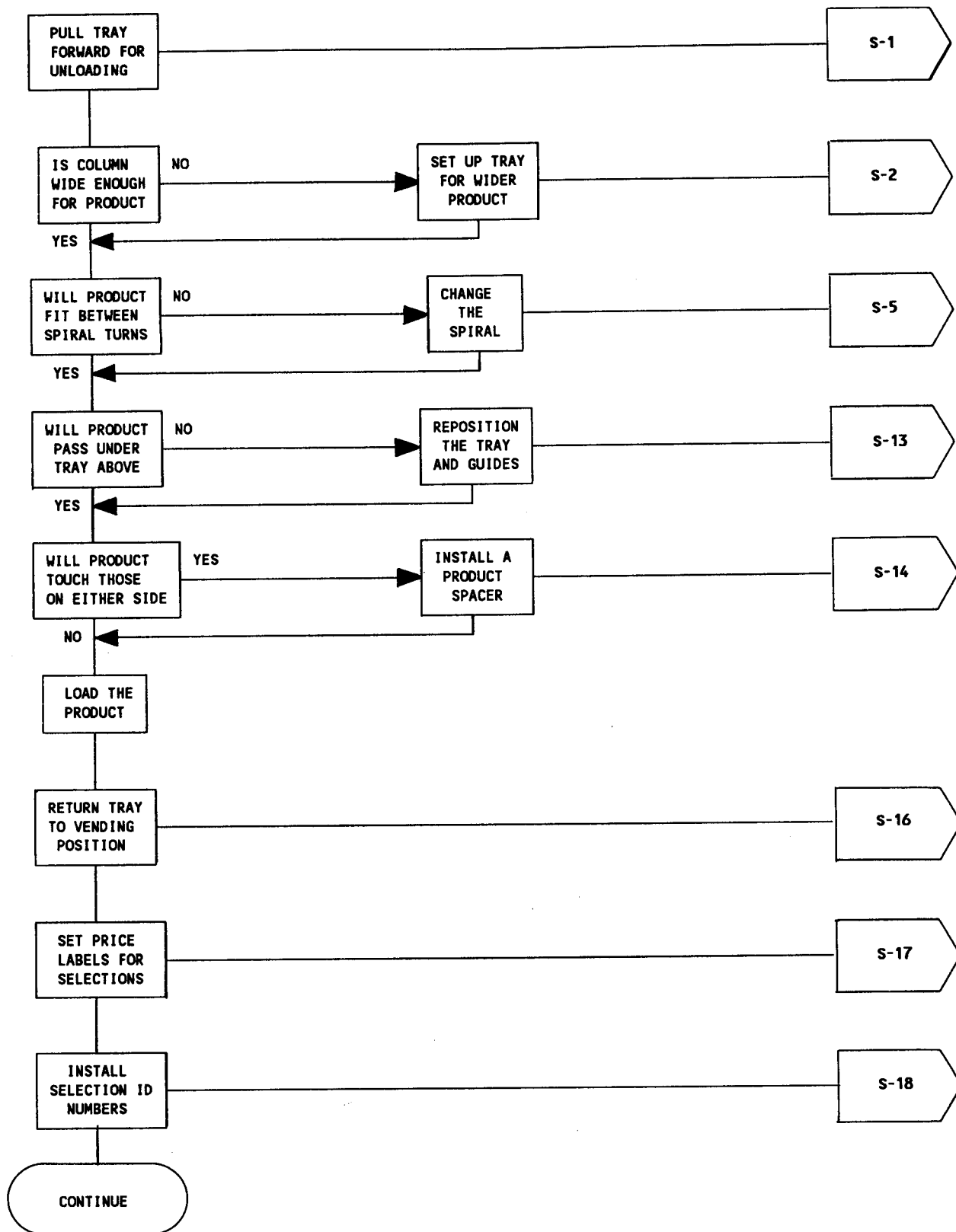

S-1 Putting Tray In Loading Position

- * Place both hands on the Tray as shown in Figure S-1a.
- * Lightly push back on the Tray with your palms. This will release the Tray Catches on the sides of the Tray.
- * Push down on the Tray Catches with your thumbs.
- * Pull the Tray forward until you hear and feel the rear rollers of the Tray drop into a cut-out in the top of the Guide Rail.
- * Continue pulling the Tray forward for another inch. You will then be able to tilt the Tray downward into the loading position as shown in Figure S-1b.

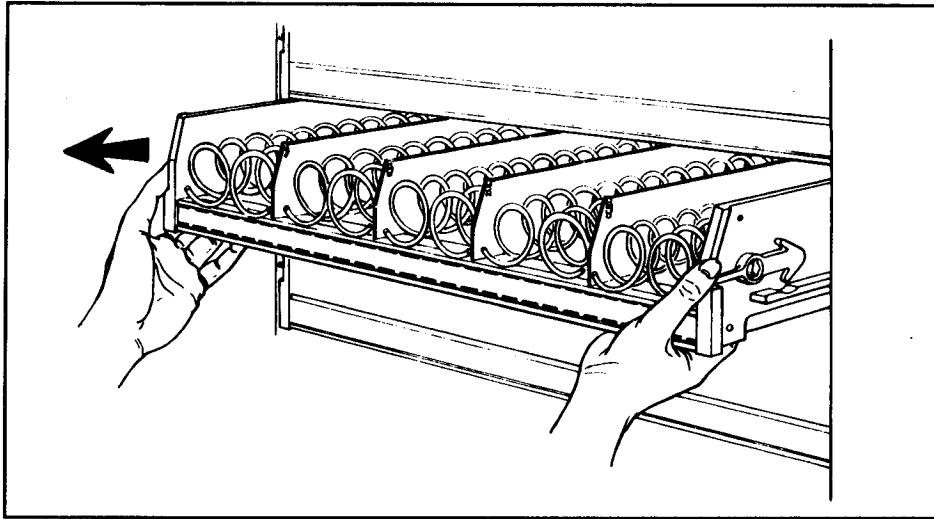

Figure S-1a

NOTE

When the Cabinet Door is not fully open,
the bottom tray will rest on the Delivery Pan Assembly.
Handle the Tray with care to avoid scratching the Delivery Pan Assembly.

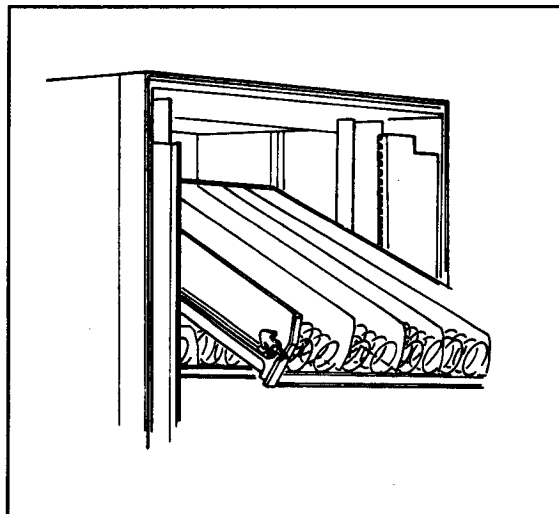
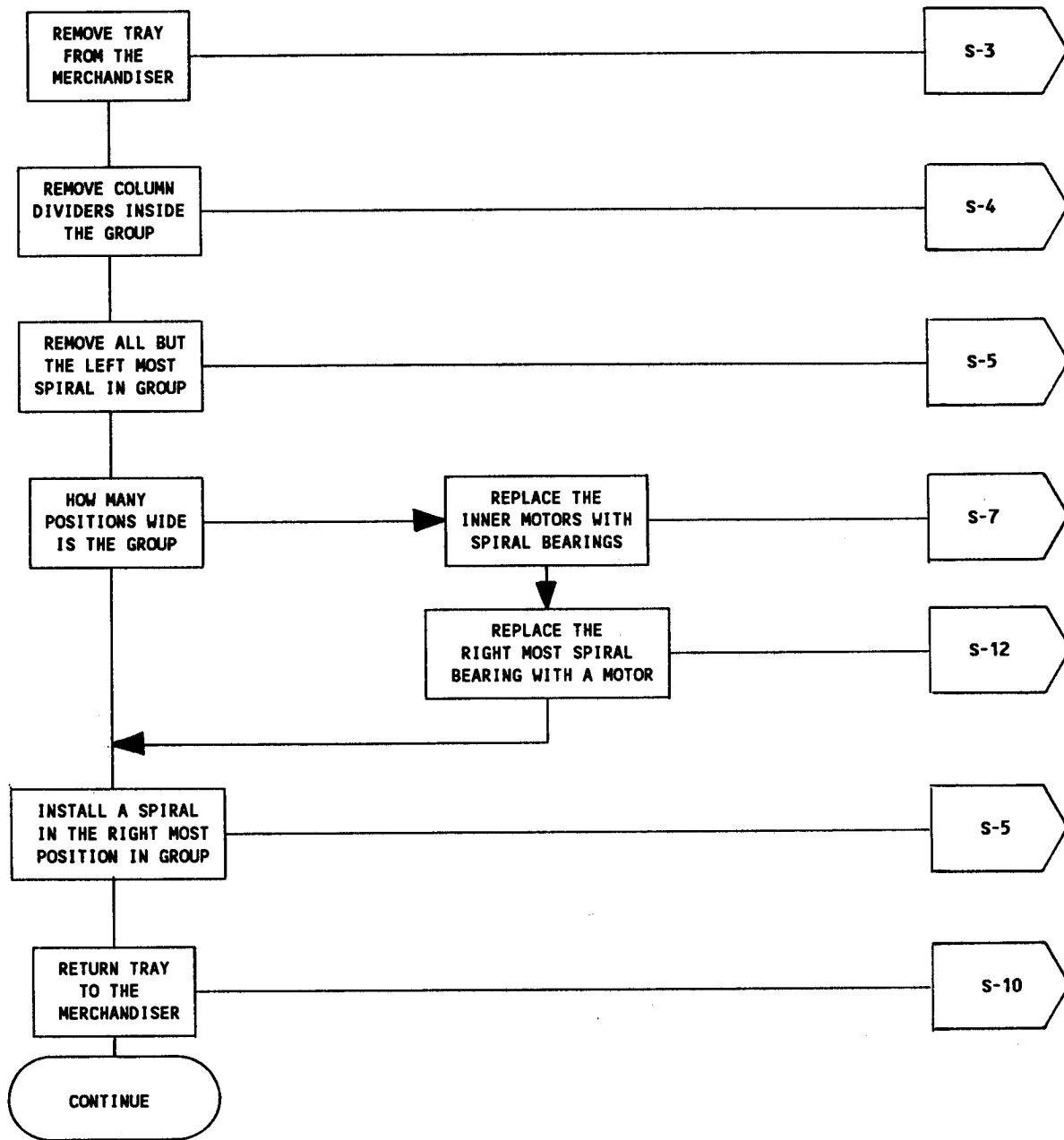

Figure S-1b

**CANDY TRAY
SET-UP FOR WIDER PRODUCTS**



NOTE

The left-most position of a coupled group must be position 0 or an even numbered position.

- * Push back on the tray slightly with with your palms. This releases the the tray catches.
- * Push down on the tray catches with your thumbs.
- * Pull the tray forward until you hear and feel the back rollers of the tray drop into the cut-out in the top of the guide rail. See Figure S-3a.

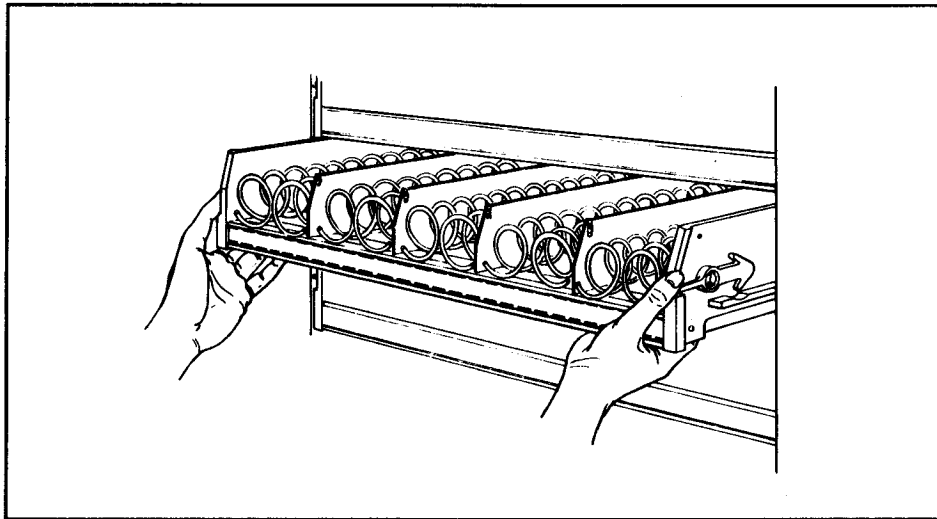

Figure S-3a

- * Lift up on the tray and slide it toward the back. No more than an inch should be needed.
- * The tab near the back of the tray should align with the cut-out in the top of the guide rail. See Figure S-3b.
- * Lift the tray clear of the guide rail and out of the merchandiser.

NOTE

When the cabinet door is not fully open, exercise extra care in removing the bottom tray. Failure to do so may result in damage to the tray or to the delivery pan assembly.

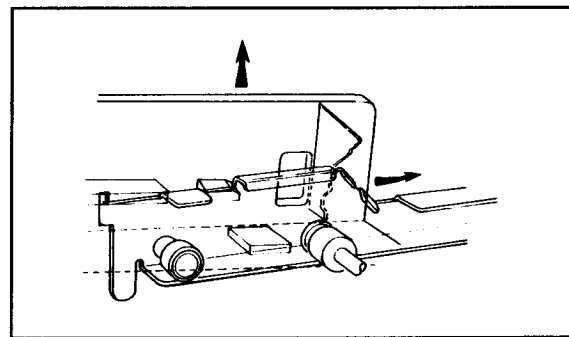

Figure S-3b

* Push the Column Divider toward the back of the Tray. See Figure S-4a.

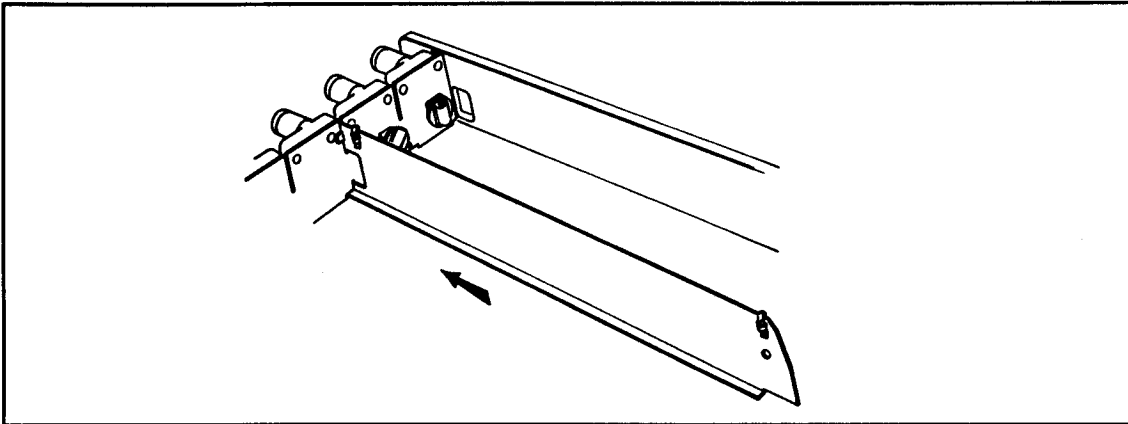

Figure S-4a

* Lift the Column Divider clear of the Tray. See Figure S-4b.

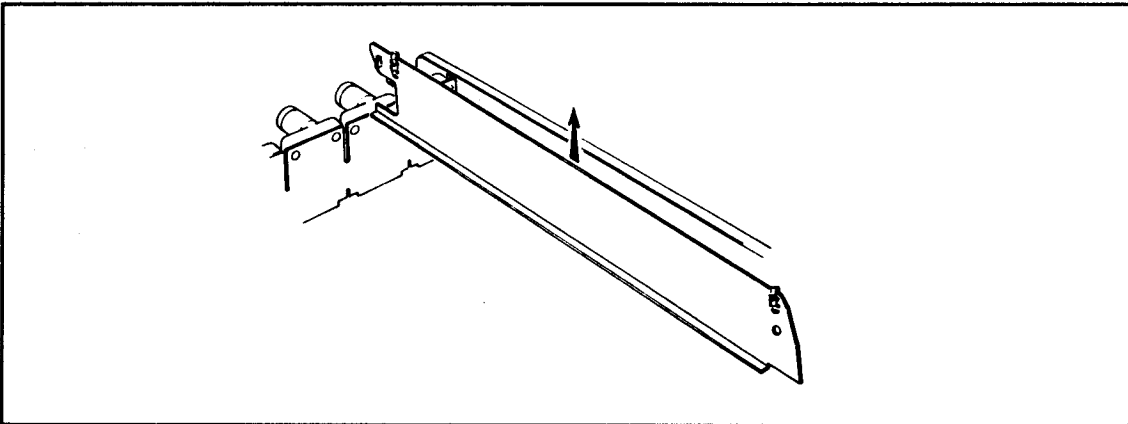
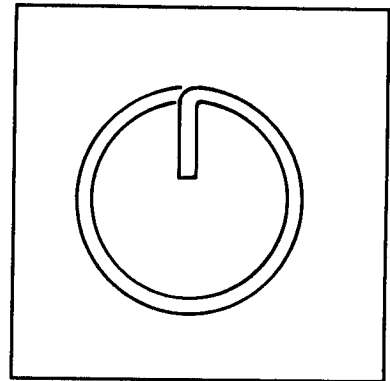

Figure S-4b

* All spirals are the same diameter.



* There are two types of spirals:

COUNTER-CLOCKWISE

CLOCKWISE

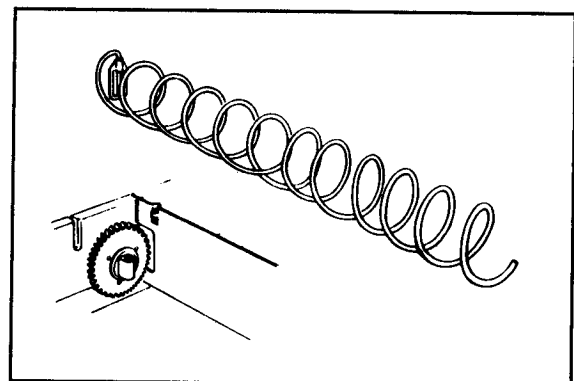
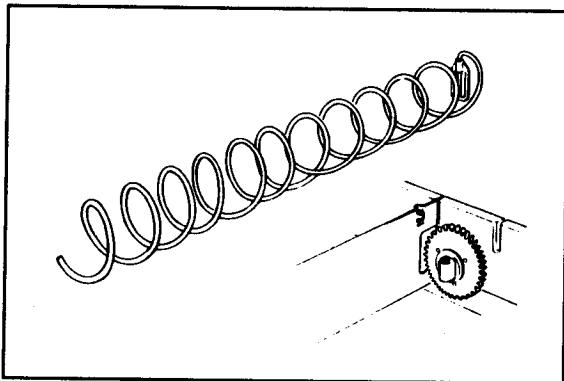

* Spirals are available in seven different capacities. Four of these are standard and three are options.

ITEM CAPACITY OF SPIRAL	PART NUMBER	
	CLOCKWISE (RH)	COUNTERCLOCKWISE (LH)
11 (Standard)	1477027	1477024
13 (Standard)	1477033	1477030
15 (Standard)	1477039	1477036
20 (Standard)	1477045	1477042
25 (Optional)	1477051	1477048
30 (Optional)	1477057	1477054
38 (Optional)	1477063	1477060

TO REMOVE A SPIRAL

- * Pull forward on the retaining clip and remove the end of the spiral from the spiral coupler.
- * Remove the spiral from the tray.

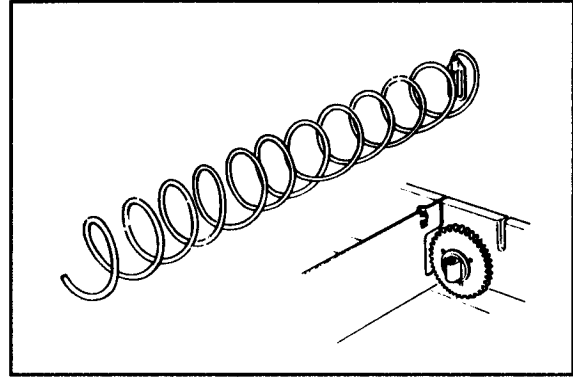
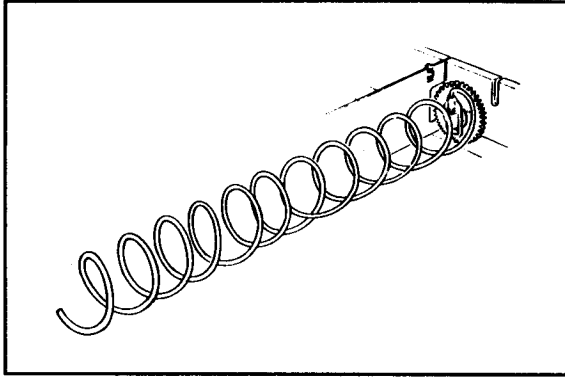

TO INSTALL A SPIRAL

- * Pull the bottom of the retaining clip toward the front of the spiral.
- * Lower the spiral into the tray column and insert the end of the spiral into the spiral coupler.
- * Release the retaining clip.

SHOULD I USE A CLOCKWISE OR A COUNTERCLOCKWISE SPIRAL?

- * The type of spiral used is determined by the column position it will occupy in the tray.
- * Refer to Figure S-5a and Table S-5a to find the correct spiral type.

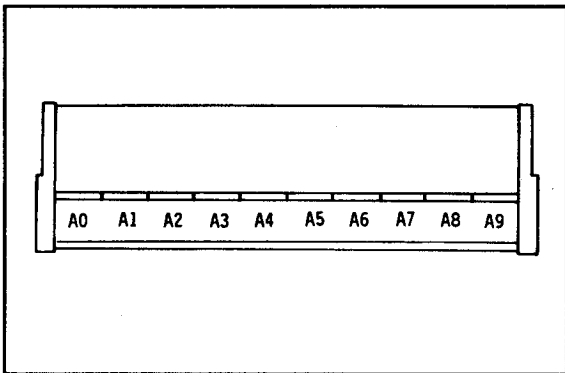

SPIRAL TYPE	COLUMN POSITION				
CLOCKWISE (RH)	A1	A3	A5	A7	A9
COUNTERCLOCKWISE (LH)	A0	A2	A4	A6	A8

Table S-5a

Figure S-5a

REMOVING A SPIRAL COUPLER

- * Pinch together the prongs on the end of the Spiral Coupler.
- * Pull the Coupler forward.

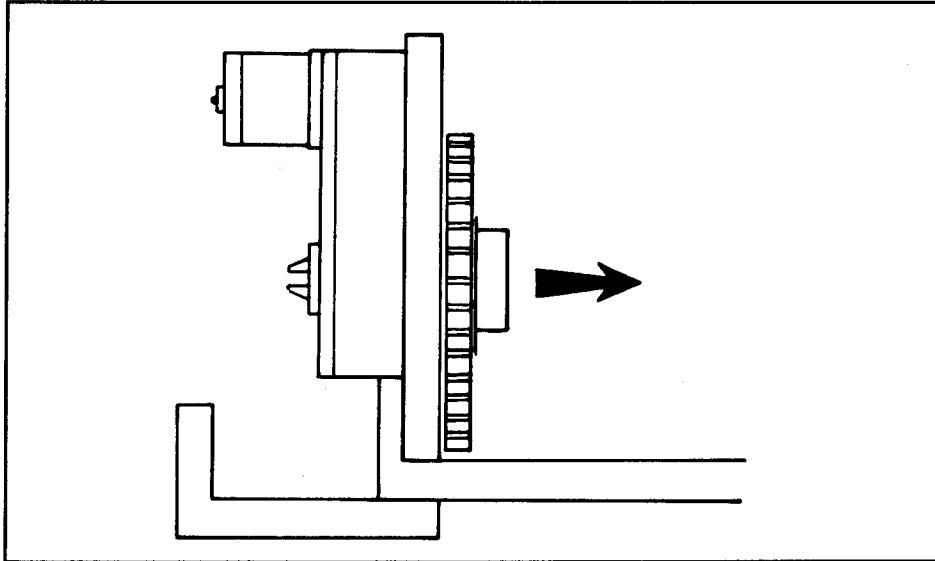

Figure S-6a

REMOVING A MOTOR

- * Disconnect the Harness from the Motor. See S-11
- * Remove the Spiral. See S-5
- * Remove the Spiral Coupler. See S-6
- * Lift the Motor clear of the Tray Assembly.

INSTALLING A SPIRAL BEARING (See Figure S-7a)

- * Put Gear in position if required in this set-up. See S-8
- * Install the Spiral Coupler. See S-9

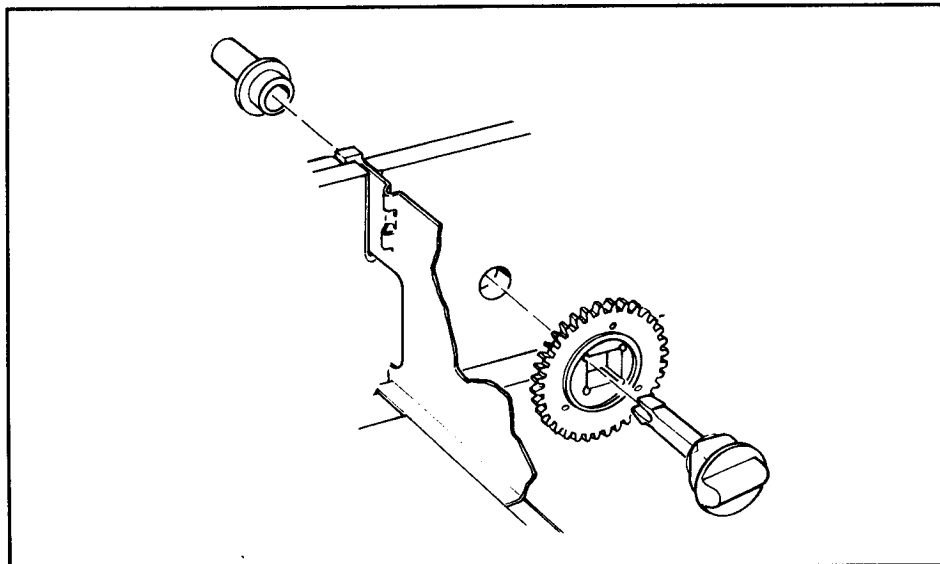

Figure S-7a

WHEN ARE GEARS USED?

- * Gears are used to mechanically couple the Spirals together.
- * This happens whenever you have two Spirals and only one Motor for vending a selection.

WHERE ARE THE GEARS PLACED?

- * The Gear is placed between the back of the Tray and the Spiral Coupler.

HOW IS THE GEAR ORIENTED? (See Figures S-8a and S-8b)

- * There are two possible orientations for the Gear.

ORIENTATION 1

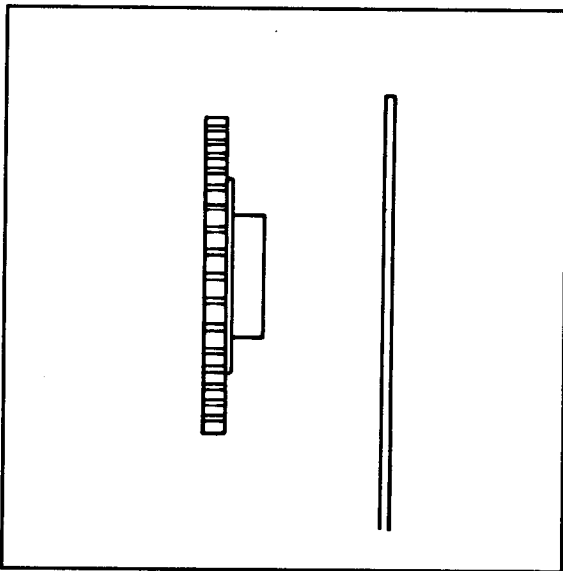

Figure S-8a

ORIENTATION 2

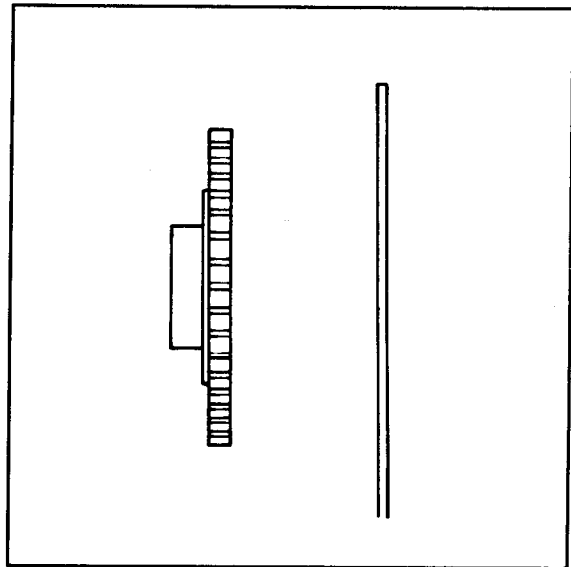

Figure S-8b

- * There are two rules to follow when orienting Gears:

RULE 1 - The Gears for selections next to each other cannot use the same orientation.

RULE 2 - All Gears for a single selection must use the same orientation.

INSTALLING A SPIRAL COUPLER

* Place Gear in position if one is required for this set-up. See S-8

WHEN USED WITH A MOTOR - See Figure S-9a

* Hold Motor in place and push Spiral Coupler through the Motor Gear Box until it licks into position.

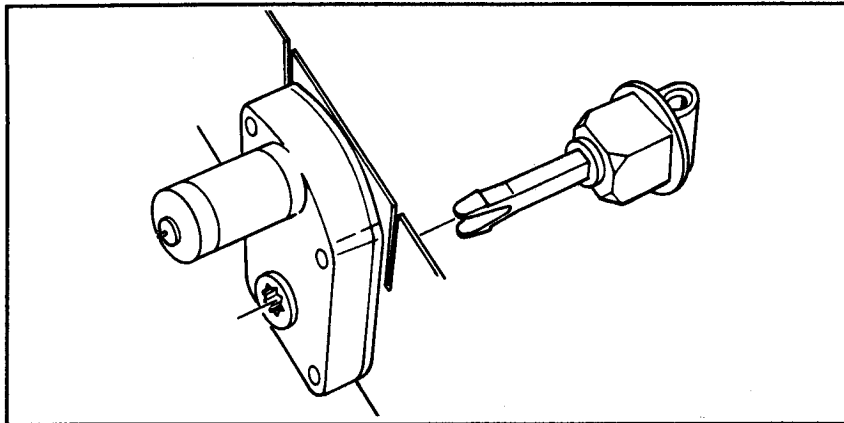

Figure S-9a

WHEN USED WITH A COUPLER BEARING - See Figure S-9b

* Hold the Coupler Bearing in place and push the Spiral Coupler through the Bearing until the Couple locks into position.

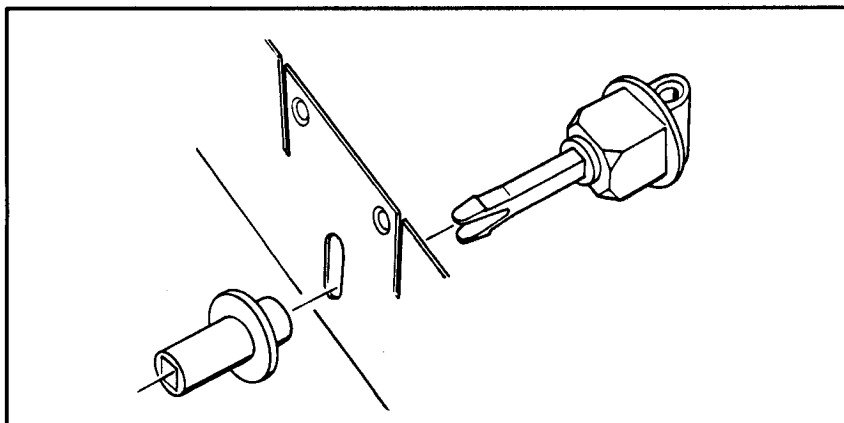
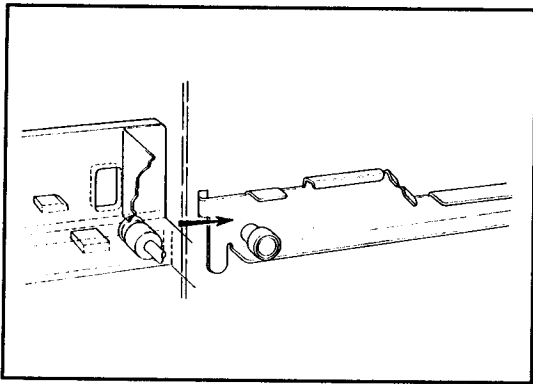

Figure S-9b

INSTALLING A TRAY IN THE MERCHANDISER

- * Study this procedure before you install a tray for the first time.
- * While you are holding the tray you will not be able to see this area.
- * Complete the following procedure when installing a tray:

1. Insert the tray so that the tray rollers pass over the tray-guide rollers.



4. Hold the tray up while pushing it toward the rear. Stop when the tab on the tray aligns with the opening in the tray guide.

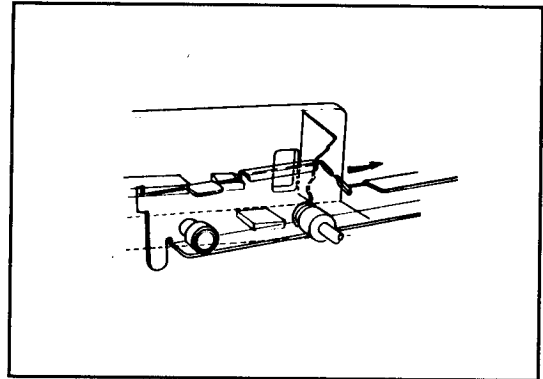

2. Bring the tray roller to rest on the tray guide.

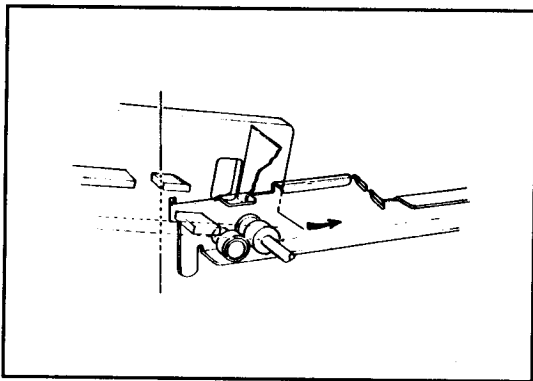

5. Lower the tray until it rests on the tray-guide roller. Push the tray in all the way.

6. The tray retaining clip will fall into the locking position.

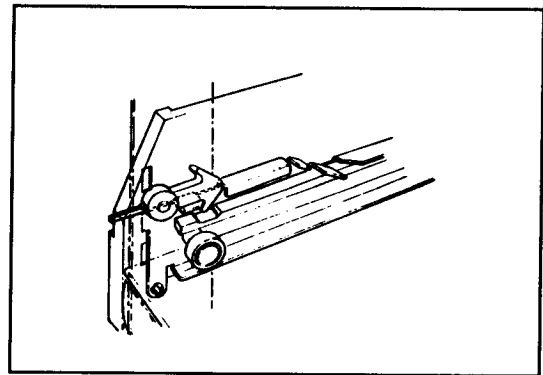

3. Tilt the tray upward.

NOTE

Hold the header on the Motor Circuit Board whenever connecting or disconnecting a Motor Harness. This will help prevent breakage of the Circuit Board.

DISCONNECTING A MOTOR HARNESS

- * Pull the harness connector away from the circuit board.
- * Tuck the unused part of the Harness out of the way in the trough at the back of the Tray.

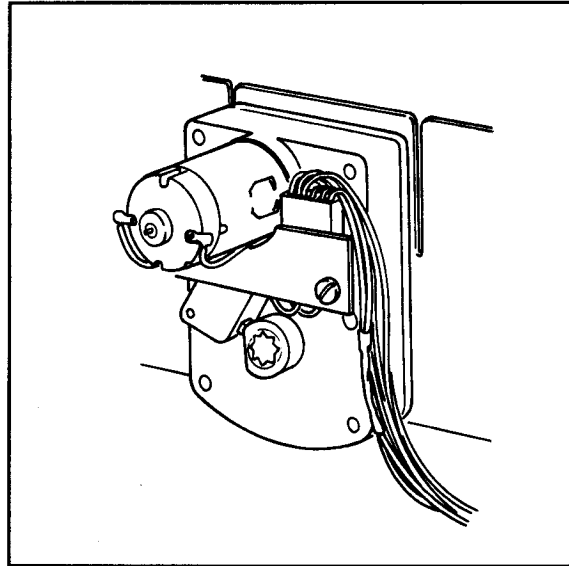

CONNECTING A MOTOR HARNESS

- * Locate the harness connector for the tray position of interest.
- * Push the harness connector over the header pins on the Motor Circuit Board.

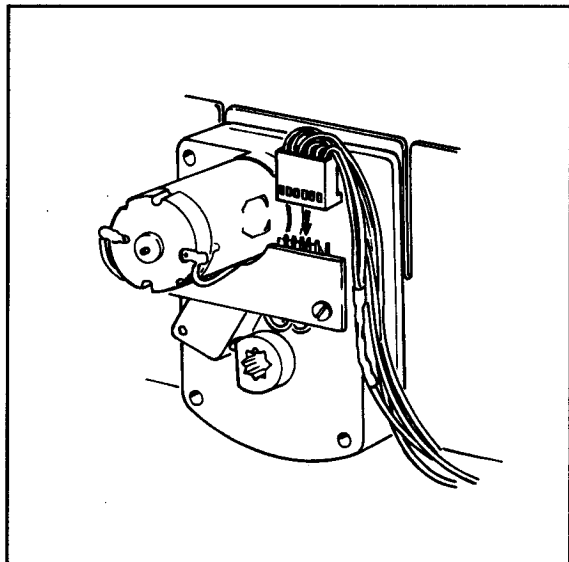

REMOVING A SPIRAL MOTOR

- * Place the Tray in the loading position. See S-1
- * Disconnect the Motor Harness. See S-11
- * Remove the Spiral. See S-5
- * Remove the Spiral Coupler. See S-6
- * Lift the Motor clear of the Tray.

INSTALLING A SPIRAL MOTOR (See Figure S-12a)

- * Place the Tray in the loading position. See S-1
- * Place the Motor in the correct position at the rear of the Tray.
- * Place a Gear in position if required by this set-up. See S-8
- * Install a Spiral Coupler. See S-9

NOTE

*The Spiral Coupler
holds the motor
in place.*

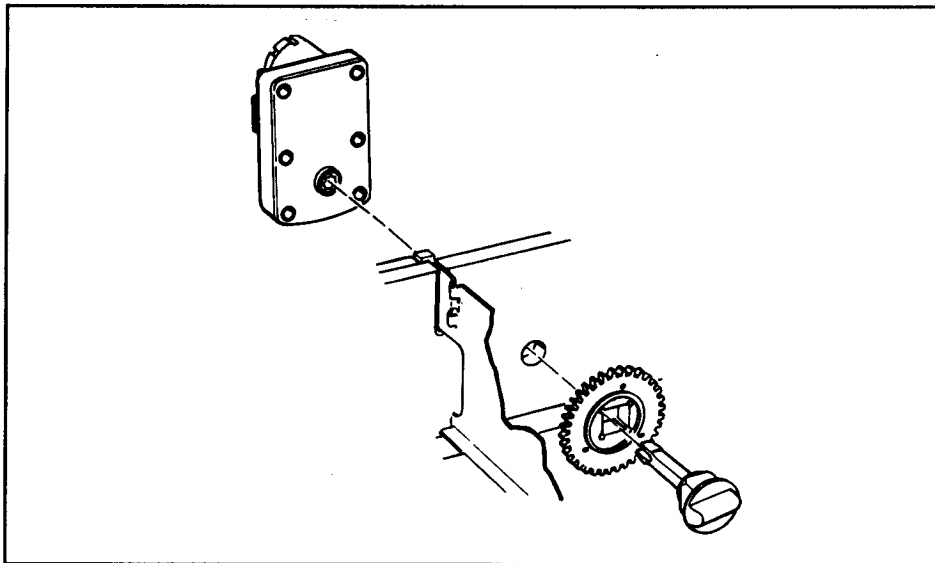

Figure S-12a

- * Connect the Motor Harness. See S-11

- * This merchandiser can be adjusted to vend taller products.
- * When you increase the product height for one tray, you will be decreasing the product height available for the tray below, the tray above or sometimes for both of these trays.
- * The Trays can be relocated as follows:

6-TRAY CONFIGURATION						
TRAY	A (BOTTOM)	B	C	D	E	F
POSSIBLE POSITIONS	1	2	3	3	3	3

* When relocating Trays, the following rules apply:

NEW POSITION OF TRAY BEING MOVED	ALLOWABLE POSITIONS FOR TRAY ABOVE	ALLOWABLE POSITIONS FOR TRAY BELOW
UPPER	MIDDLE UPPER	UPPER MIDDLE LOWER
MIDDLE	UPPER MIDDLE LOWER	UPPER MIDDLE LOWER
LOWER LOWER	UPPER MIDDLE LOWER	MIDDLE LOWER

* The slot number used in the Tray-Guide Mounting Channels will be the same as the slot number used in the Receptacle Mounting Channel.

**FRONT GUIDE
MOUNTING CHANNEL**

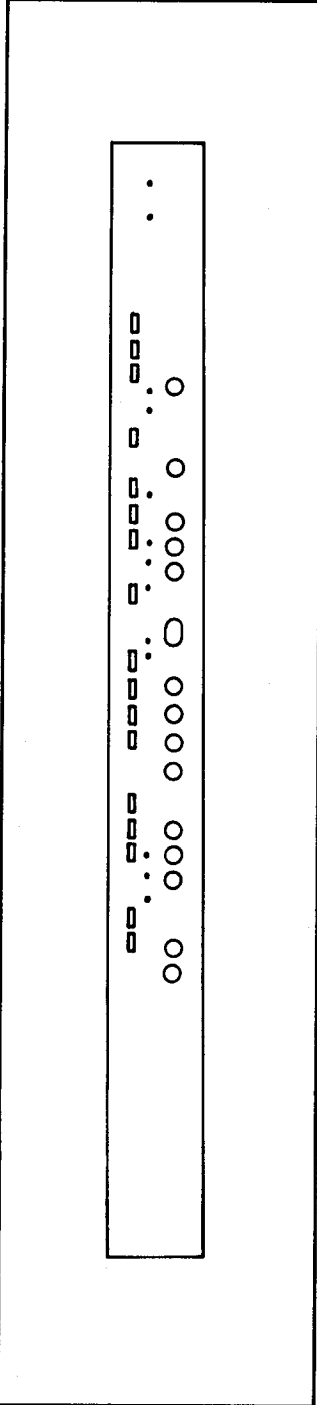

**REAR GUIDE
MOUNTING CHANNEL**

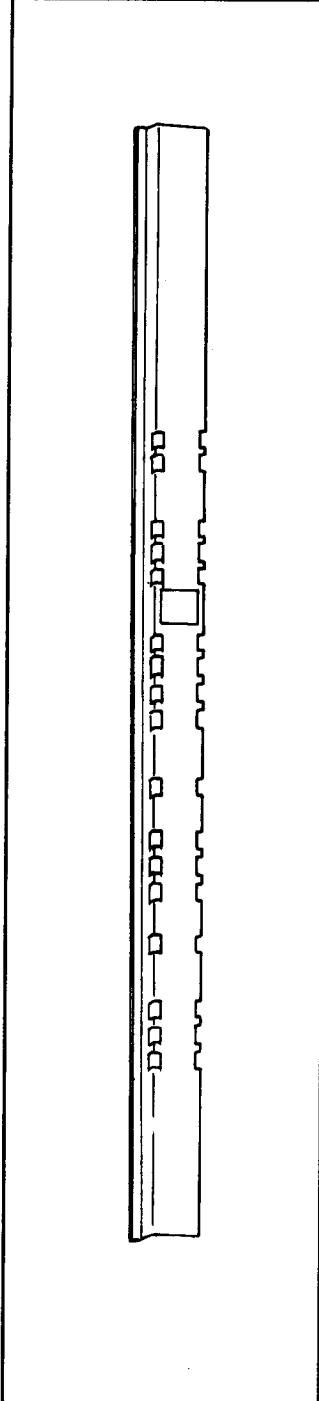

**RECEPTACLE BLOCK
MOUNTING CHANNEL**

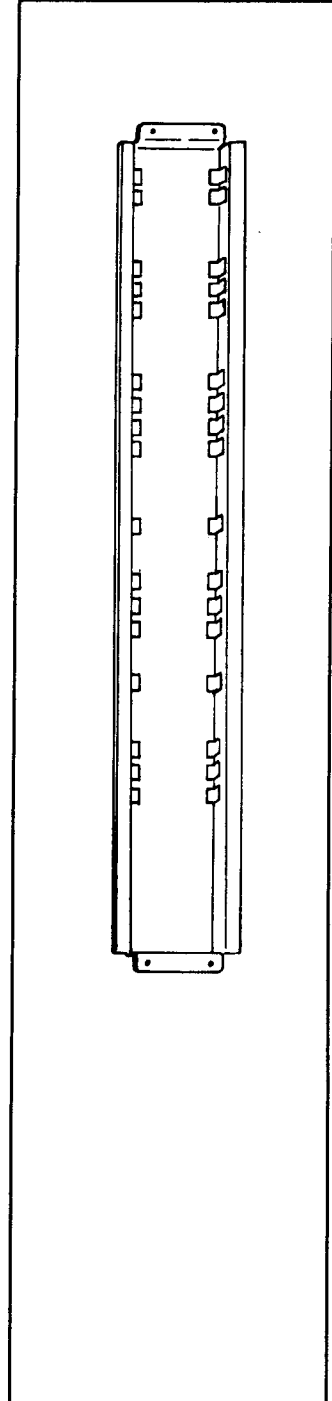

TO RELOCATE A TRAY.

1. Remove the Tray from the merchandiser. See S-3
2. Remove the screw that secures the Left Tray-Guide to the Front Guide-Mounting Channel. See Figure S-13a.

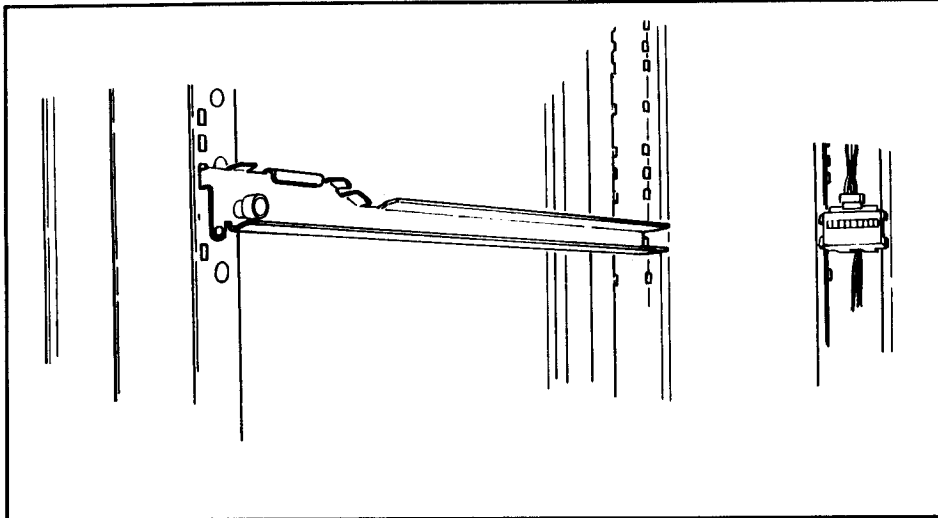

Figure S-13a

3. Tap up on the Tray Guide and unseat the Guide Rail tabs from the channel slots.
4. Pull the Guide Rail away from the Channels.
5. Move the Tray Guide to the desired position.
6. Insert the Guide Rail tabs into the Channel slots. See Figure S-13b.
7. Tap down on the Guide Rail to seat the tabs in the Channel slots.
8. Replace the screw that secures the Guide Rail to the Front Guide-Mounting Channel. See Figure S-13a.
9. Repeat Steps 2-8 for the Right Guide Rail.
10. Disconnect the Harness from the Receptacle Block. See Figure S-13a.
11. Press the blade of a slotted head screw driver between one of the Receptacle Block locking tabs and the Receptacle Mounting Channel. See Figure S-13c. This will unseat the locking tab.
12. Pull the Receptacle Block away from the Channel.
13. Move the Receptacle Block to the desired position.

14. Push the tabs of the Receptacle Block into the slots in the Channel.
15. Reconnect the Harness to the Receptacle Block.
16. Return the Tray to the Merchandiser. See S-10

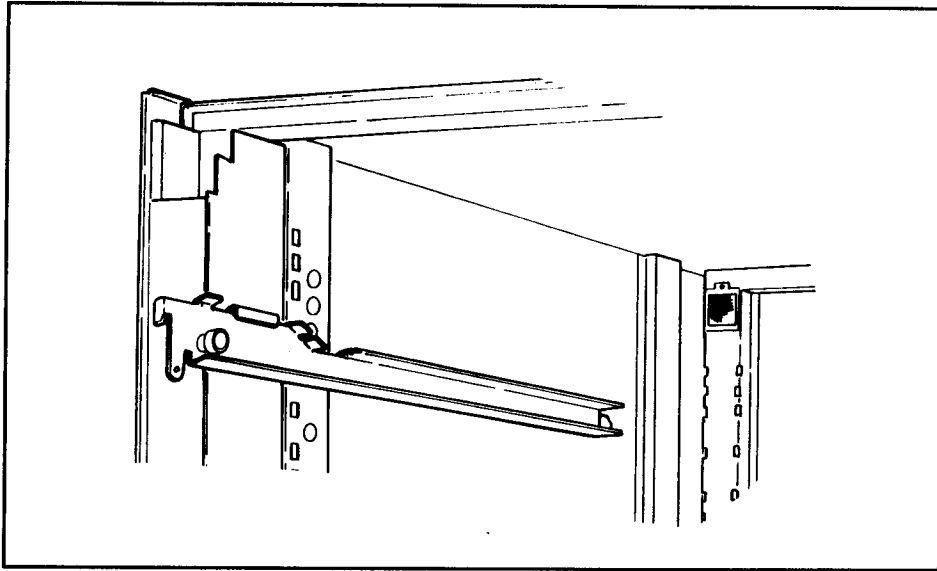

Figure S-13b

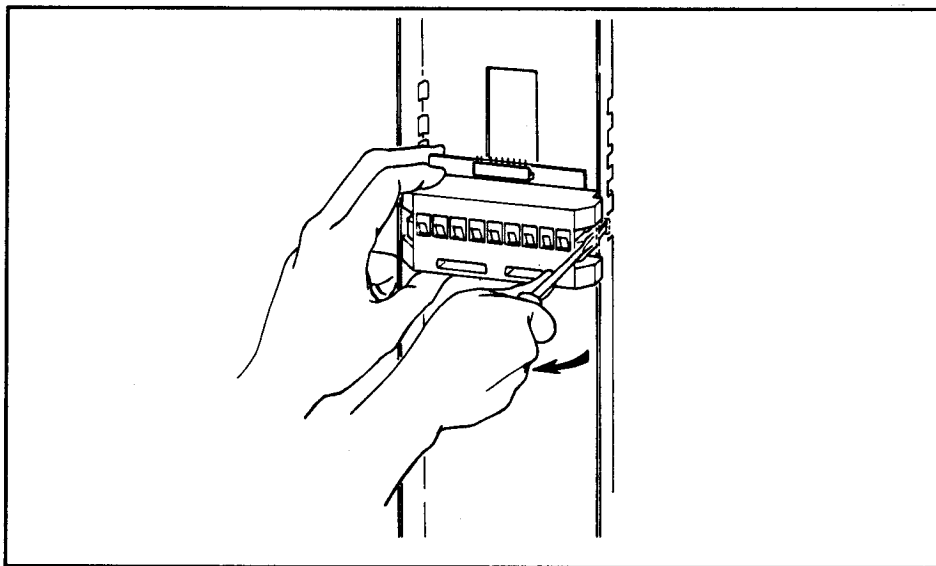

Figure S-13c

INSTALLING A PRODUCT SPACER

Insert the mounting pins of the Product Spacer into the Column Divider. See Figure S-14a

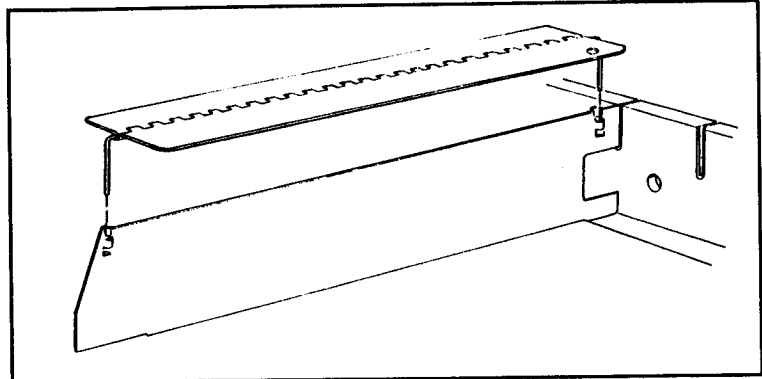

Figure S-14a

ADJUSTING A PRODUCT SPACER

With product loaded in Tray, rotate the Product Spacer up or down to keep the product upright. See Figure S-14b.

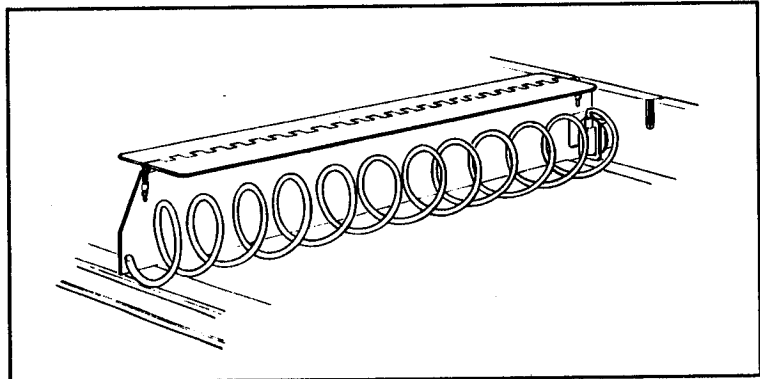

Figure S-14b

REMOVING A PRODUCT SPACER

Pull the mounting pins of the Product Spacer from the Column Divider. See Figure S-14c.

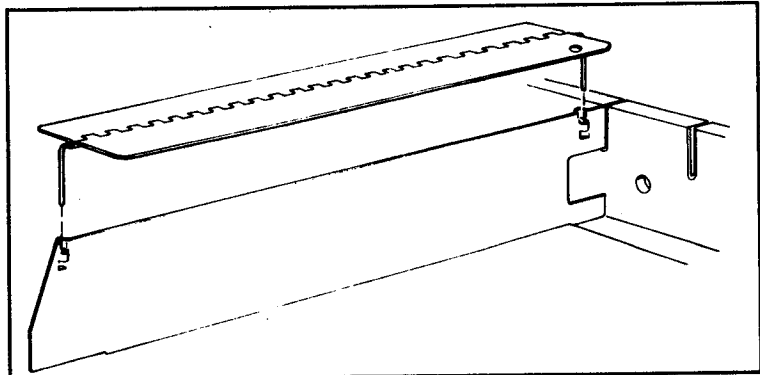
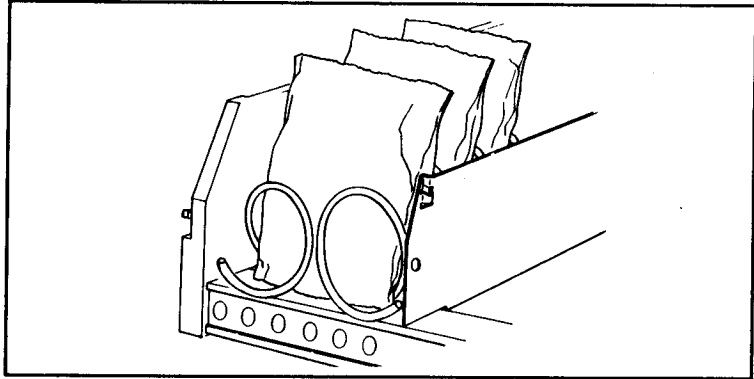

Figure S-14c

- * Place Tray in the loading position. See S-1
- * Begin loading products at the front of the Tray and work to the back.
- * Position the product so the package rests on the tray.

CORRECT LOADING
OF SNACKS



CORRECT LOADING
OF CANDY

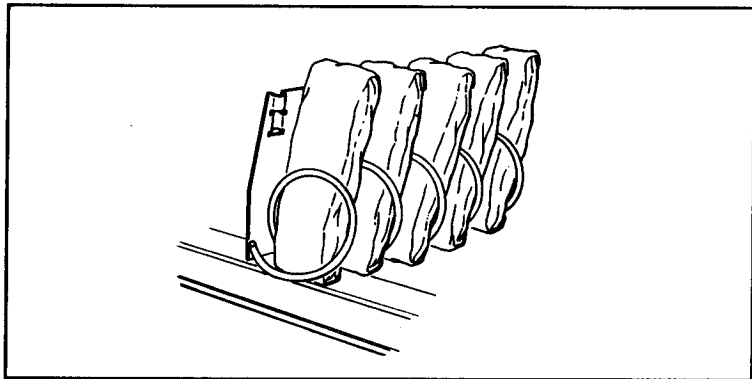

NOTE

*Be sure there are
no empty positions
between products
in each Spiral.*

- * DO NOT force the product into the Spiral.
- * If the product is too tight or too loose, change the spiral size. See S-12

SPECIAL CONSIDERATIONS

Bagged Products - position package upright, then push tops slightly toward the rear of the Tray

Thin Packages - position package upright

KitKat - the two right most candy columns are designed to accept the KitKat candy bar

WHEN THE TRAY IS IN THE LOADING POSITION:

- * Lift the Tray until it is parallel to the floor. See Figure S-16a.

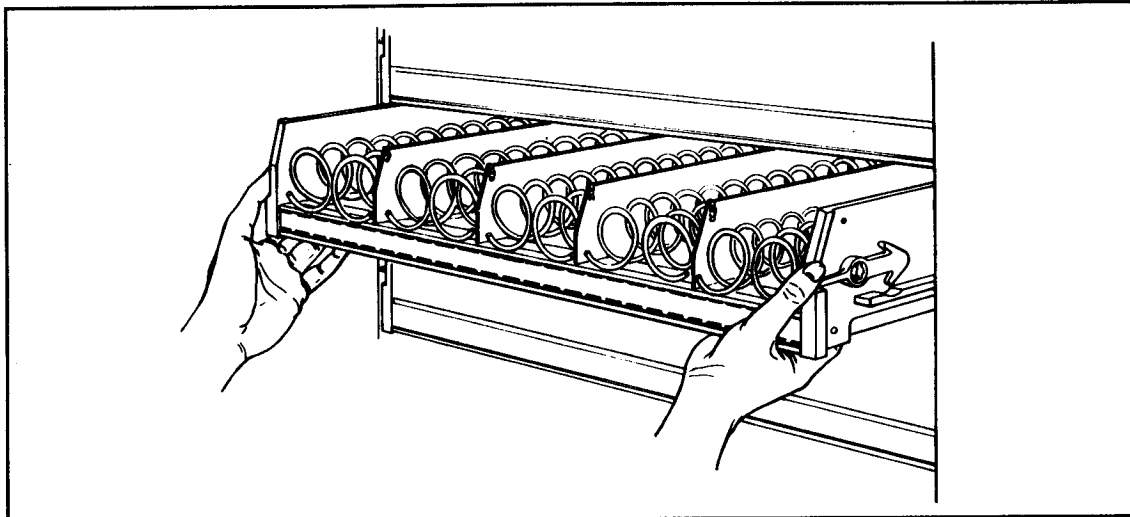

Figure S-16a

- * Push the Tray toward the back of the cabinet.
 - The connector on the back of the Tray mates with the Receptacle Block
 - The retaining clips on the sides of the Tray lock into position.

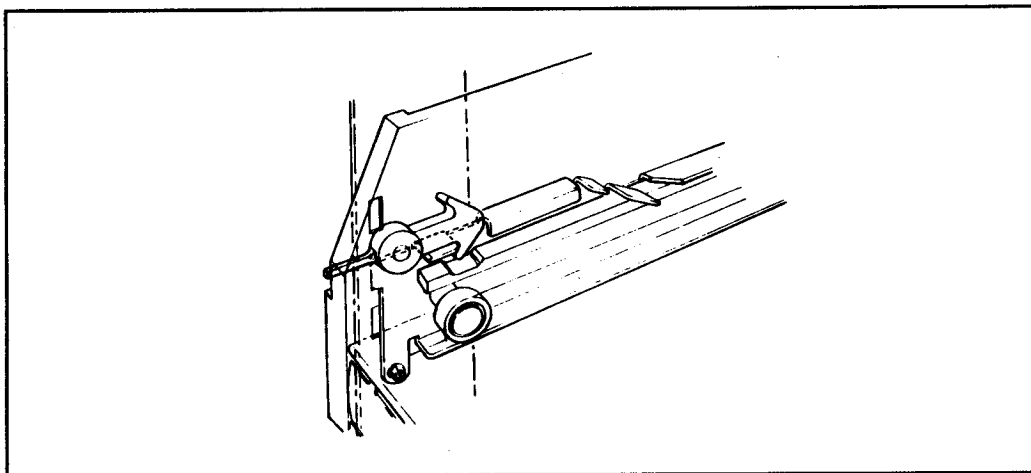

Figure S-16b

Price labels are printed on coiled-up rolls. You will find these in the plastic bag that contained this manual. See Figure S-17a.

There are two types of price rolls:

- * Dollar Roll - 1 to 12 increments of 1
- * Cents Roll - 00 to 95 increments of 05

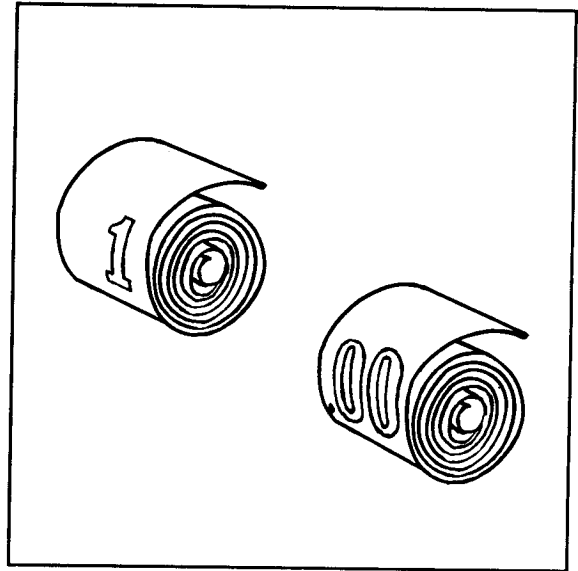

Figure S-17a

INSTALLING PRICE LABELS

- * There are three pairs of slots in the front of the Tray for each column position.
- * Insert the dollar roll in the left-most pair of slots if the price is \$1.00 or more. See Figure S-17b.
- * Insert the cents roll in the center pair of slots. See Figure S-17b.
- * The low-number end of the roll goes in the top slot and the high-number end of the roll goes in the bottom slot.

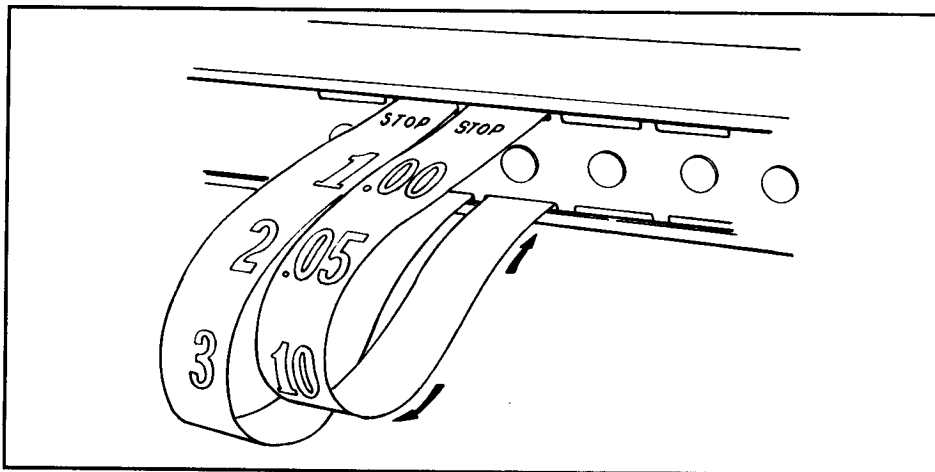

Figure S-17b

ADJUSTING THE PRICE LABELS

* You can set selection prices within the following range:

Minimum Price \$.00

Maximum Price \$12.95

Increment \$.05

* Use your thumb to move each price roll up or down as needed to set the desired price. See Figure S-17c.

NOTE

*You will see the word STOP
near either end of the roll.*

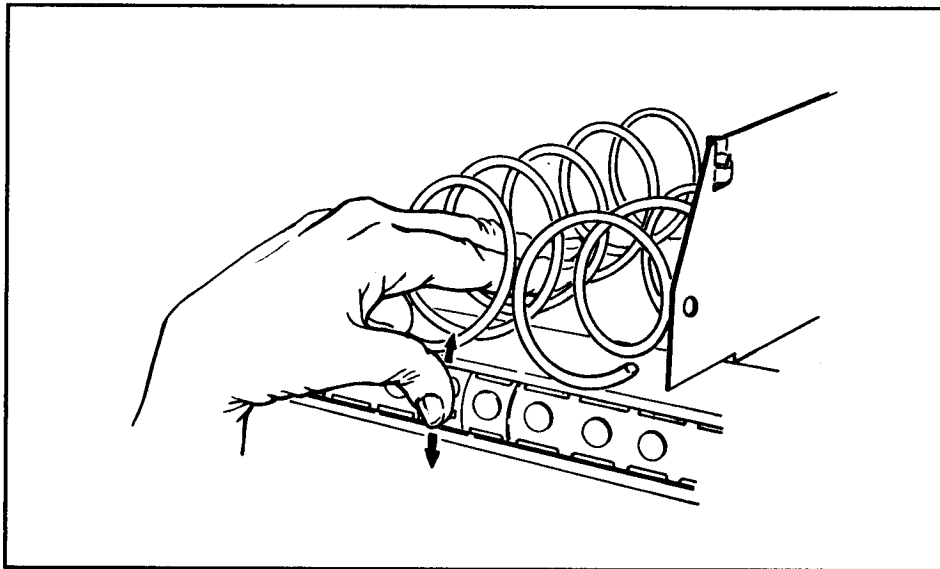

Figure S-17c

Selection ID Numbers are printed on clear plastic labels. You will find these in the plastic bag that contained this manual. See Figure S-18a.

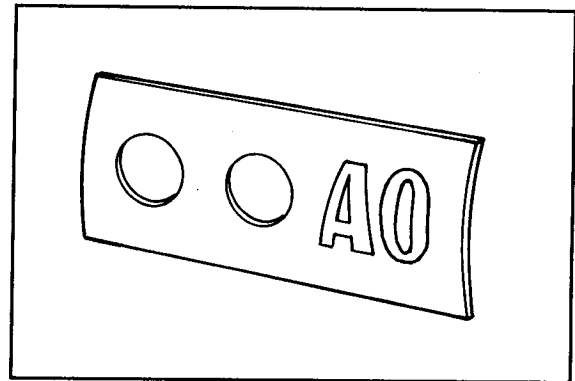

Figure S-18a

INSTALLATION OF SELECTION ID NUMBERS

- * The price label should be installed first.
- * Press the two long edges of the label together.
- * Snap the label into position on the front of the Tray. See Figure S-18b.

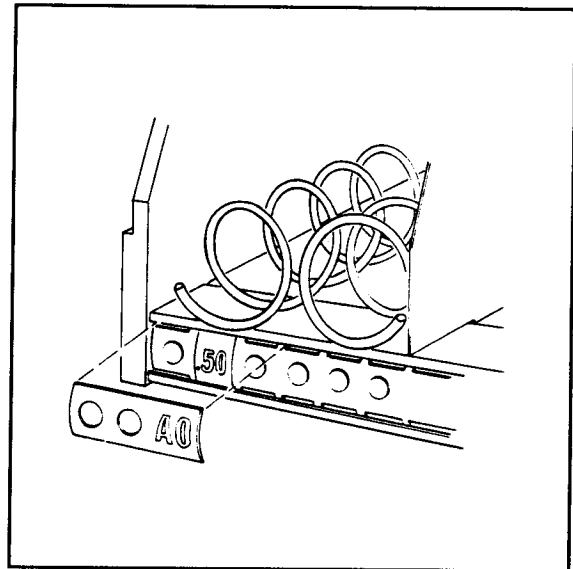

Figure S-18b

WHICH LABEL GOES WITH WHICH SELECTION?

		MOTOR POSITION									
TOP TRAY	TRAY A	A0	A1	A2	A3	A4	A5	A6	A7	A8	A9
	TRAY B	B0	B1	B2	B3	B4	B5	B6	B7	B8	B9
	TRAY C	C0	C1	C2	C3	C4	C5	C6	C7	C8	C9
	TRAY D	D0	D1	D2	D3	D4	D5	D6	D7	D8	D9
	TRAY E	E0	E1	E2	E3	E4	E5	E6	E7	E8	E9
BOTTOM TRAY	TRAY F	F0	F1	F2	F3	F4	F5	F6	F7	F8	F9

EXAMPLE OF A
BASIC SNACK
TRAY

LABEL TO USE

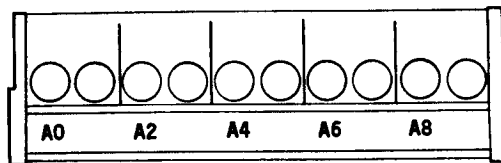

EXAMPLE OF A
BASIC CANDY
TRAY

LABEL TO USE

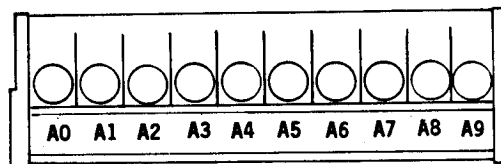

EXAMPLE OF A
COUPLED CANDY
TRAY

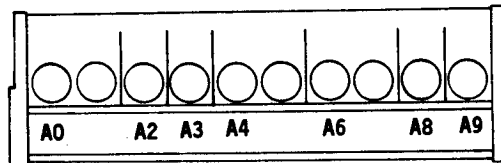

* When motor positions have been coupled together, the *SMALLEST EVEN-NUMBERED* position within the group will be the selection ID Number that you should use for this selection.

MECHANICAL SET-UP OF GUM & MINT DISPENSER

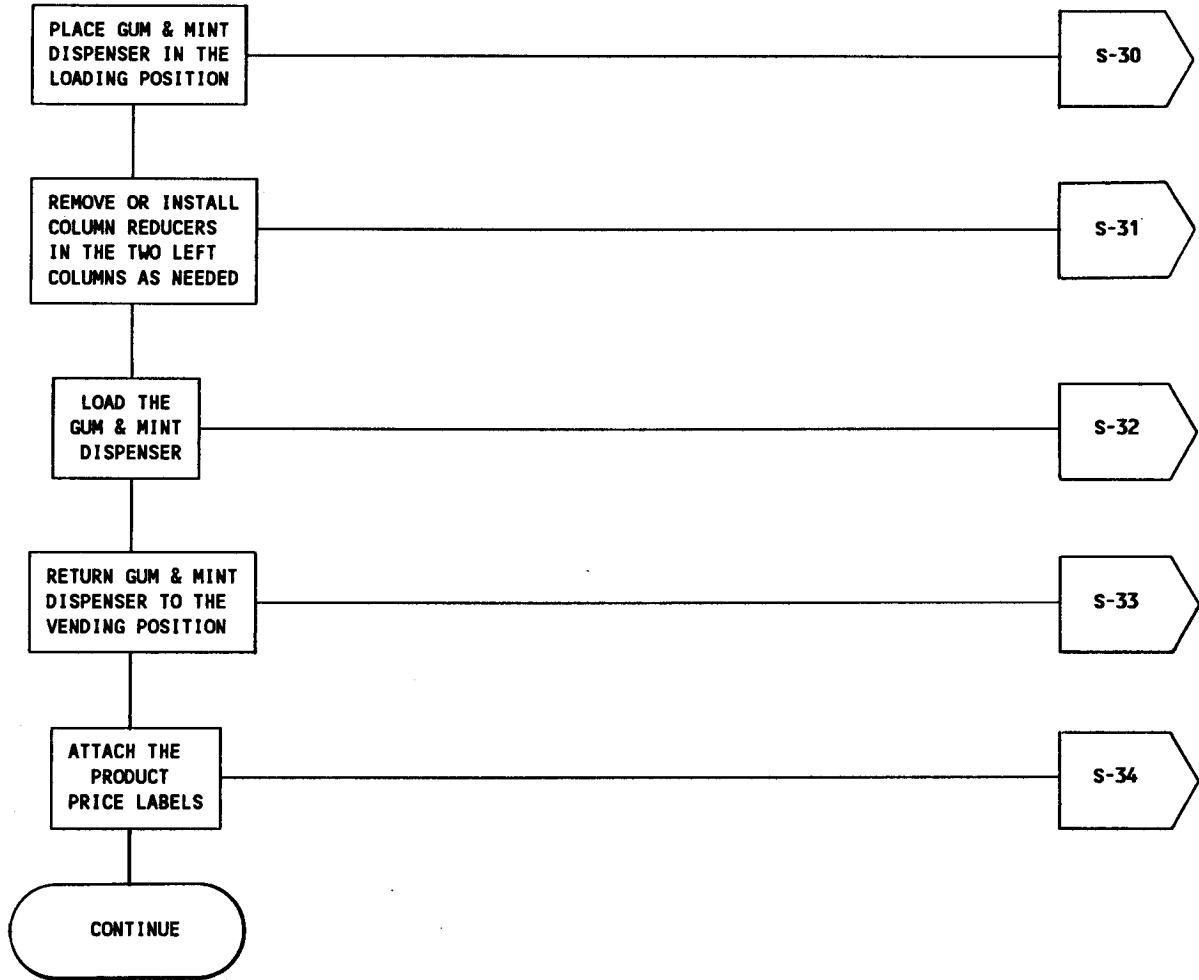

- * The Gum & Mint Assembly is hinged to the Delivery Pan Assembly.
- * The Gum & Mint Assembly is held in the vending position by two magnets.
- * On version number 1, pivot the Gum & Mint Assembly upward until the support arms fall into the locked position. See Figure S-30a below.
- * On version number 2, the Gum & Mint assembly is held in the loading position by a hook and a loop. One end of the hook is attached to the right side of the door. The loop is mounted on the right side of the Gum & Mint assembly. Use the loop as a handle and raise the Gum & Mint magazine with your left hand. Use your right hand to move the free end of the hook so it catches the loop. This will hold the magazine while you are loading it with product. See Figure S-30b below.
- * The lid of the Gum & Mint assembly is held closed by two magnets.
- * Pivot the lid up and back until it is a little past the vertical position.
- * The Gum & Mint Assembly is now in the loading position

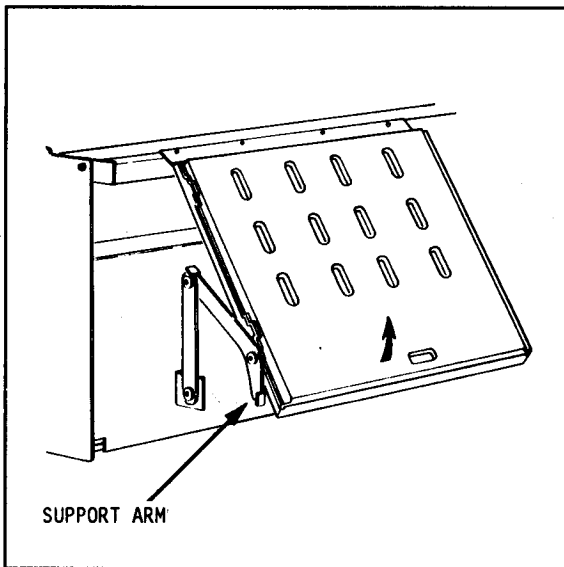

Figure S-30a Version Number 1

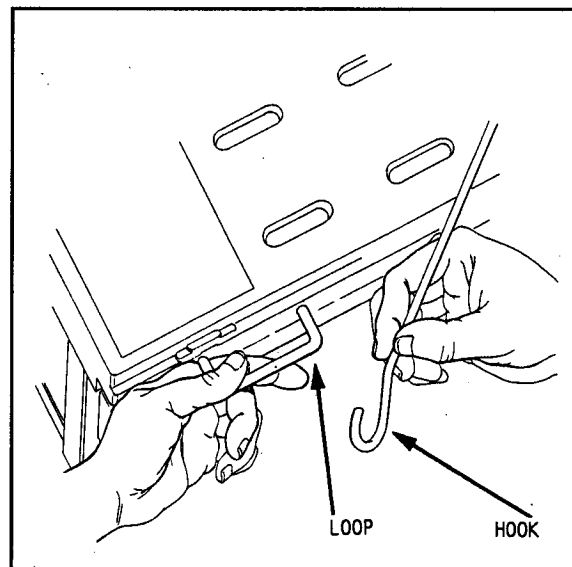

Figure S-30b Version Number 2

- * The two left-most vending columns (as seen from the loading side) can be adjusted for two different widths.
- * When a column reducer is in place, the width of the column will be 3-1/16 inches.
- * When the column reducer is removed, the width of the column will be 3-7/8 inches.

TO REMOVE A COLUMN REDUCER

- * Pull the reducer away from the cabinet door to disengage the locking tabs.
- * Lift up to remove the reducer from the Gum & Mint Assembly.

TO INSTALL A COLUMN REDUCER

- * Place the reducer on the Gum & Mint Dispenser so the locking tabs are in the slots.
- * Push the reducer toward the cabinet door to lock the reducer in position.

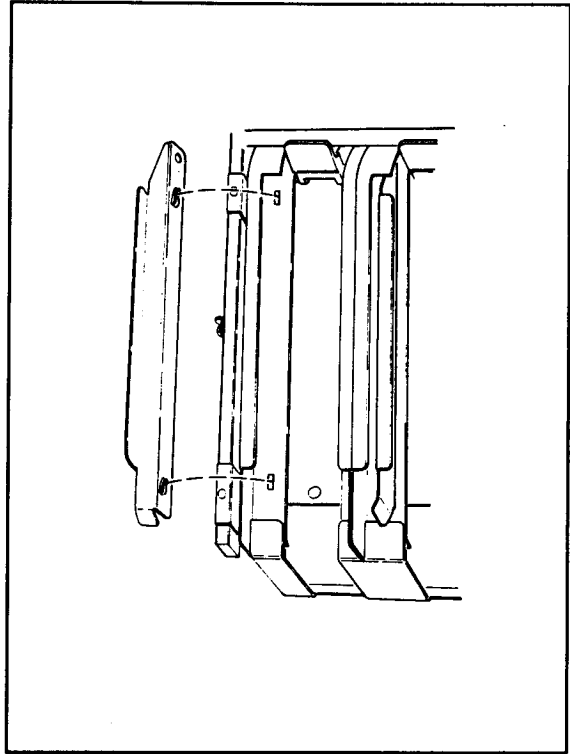

Figure S-31a

* Complete the following steps when loading the Gum & Mint Dispenser:

CAUTION

Keep your hand on the product pusher until it is locked in place. Failure to do so may result in damage to the Dispenser or in personal injury.

1. Move the product pusher into the loading position.
 - Pull back on the pusher.
 - Pull down on pusher and lock the front glide into position.

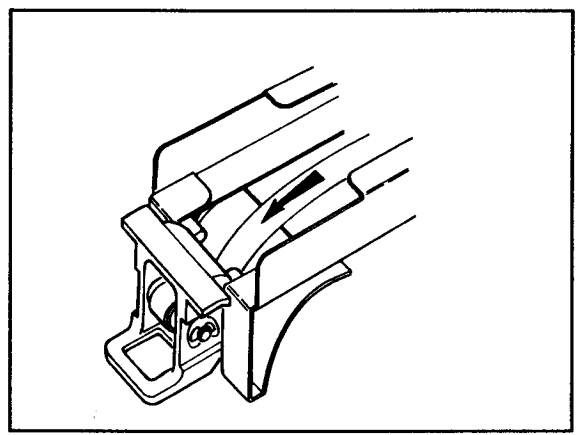

2. Load the product.
 - Push product forward.
 - Be sure last item is completely under the product retaining lip.

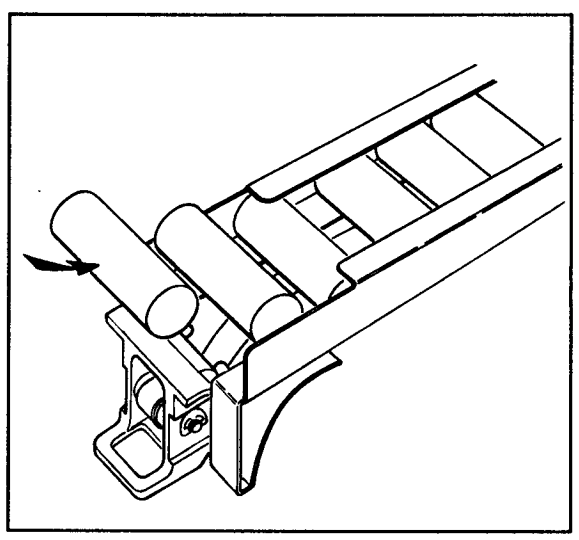

CAUTION

Keep your hand on the product pusher until it comes to rest behind the last item in the column. Failure to do so may result in damage to the dispenser, damaged product or personal injury.

3. Move the product pusher into the dispensing position.
 - Pull pusher down to unlock the front glide.
 - Guide the pusher toward the product.

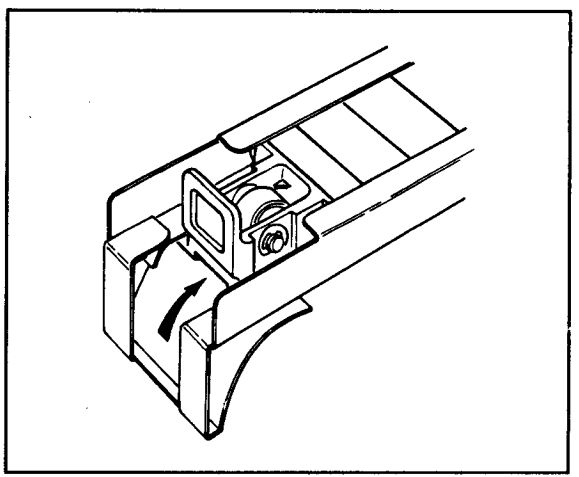

- * All product pushers should be in the vending position.
- * Close the lid of the Gum & Mint Assembly.
- * On version number 1, hold the assembly as shown in Figure S-33a. While your fingers are supporting the magazine assembly on the bottom side, press down on the support release tabs with your thumbs and lower the magazine back into the vending position.

WARNING

Your hands must be in the position shown in Figure S-33a. In addition, continue to hold the magazine assembly until it has been fully lowered. You may be injured if you do not follow this procedure.

- * On version number 2, hold the loop on the right side of the magazine with your left hand. Release the hook with your right hand and lower the magazine. Continue to hold the loop until the magazine has been fully lowered.
- * Pivot the Gum & Mint Assembly back to the vending position.

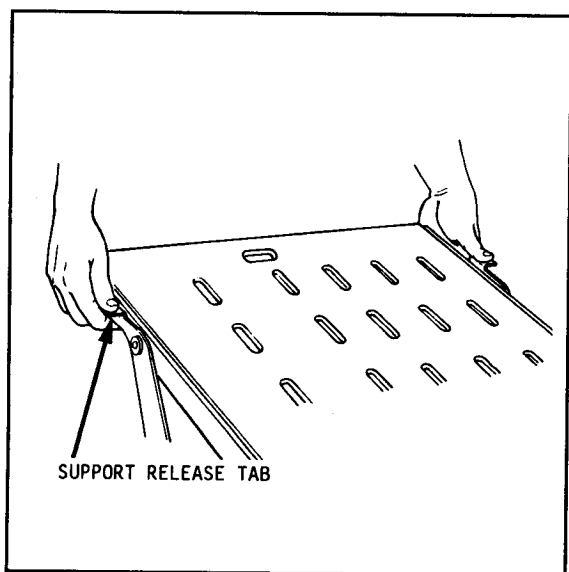

Figure S-33a Version Number 1

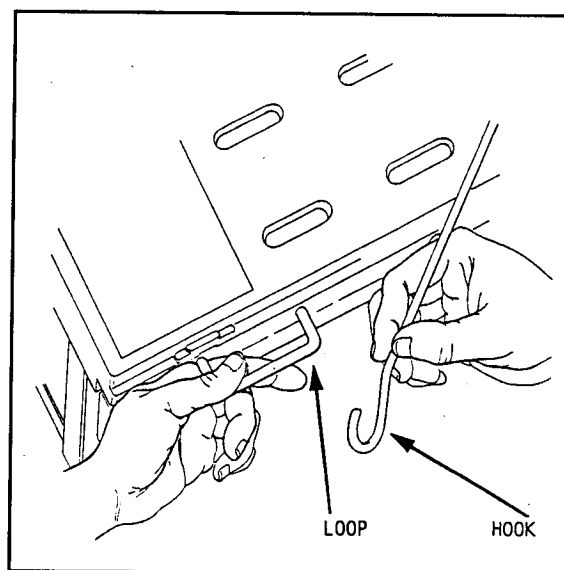

Figure S-33b Version Number 2

- * The column ID labels have already been attached to the rear delivery door.
- * A set of self-adhesive price labels are in the plastic bag that contained this manual.
- * Stick the desired price label next to the column ID number as shown in Figure S-34a.
- * Peel the old price label off when you want to change the price for a selection.

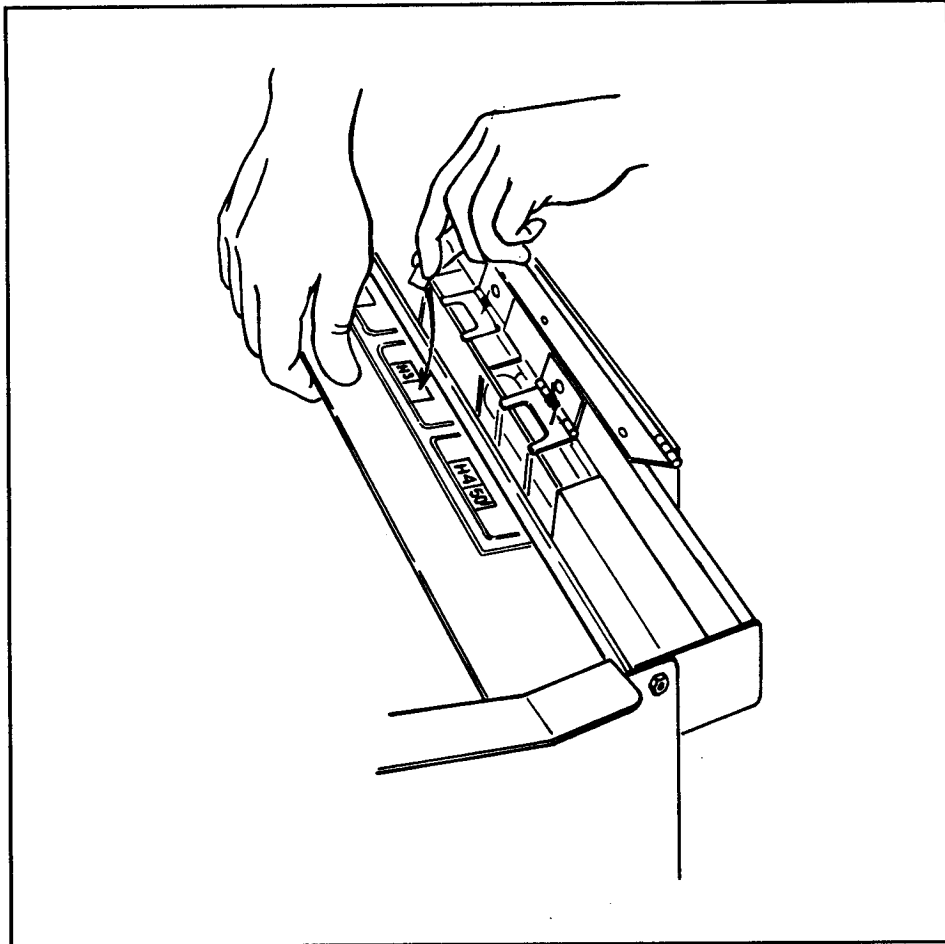

Figure S-34a

NOTES

Blank lined paper for writing notes.

The information in this part of the manual has been provided to help you determine if the merchandiser is ready to put into operation.

OPERATIONAL READINESS CHECKING PROCEDURES

- RC-1 Anti Hang-Up Procedure Overview
- RC-2 Indexing 1 Spiral Used With A Right Hand Motor
- RC-3 Indexing 1 Spiral Used With A Left Hand Motor
- RC-4 Indexing 2 Spirals Used With 1 Motor
- RC-5 Indexing 2 Spirals Used With 2 Motors
- RC-6 Installing A Product Pusher
- RC-7 Installing and Removing A Spiral Wall Retainer
- RC-8 Retrieving A Product Through the Delivery Door
- RC-9 Testing the Bill Validator

COMPLETE THE OPERATIONAL READINESS CHECK
WHEN YOU ARE INSTALLING A NEW MERCHANDISER,
WHEN YOU CAHNGE THE SET-UP OF A TRAY OR
AFTER YOU HAVE CHANGED A PART OF THE CONFIGURATION

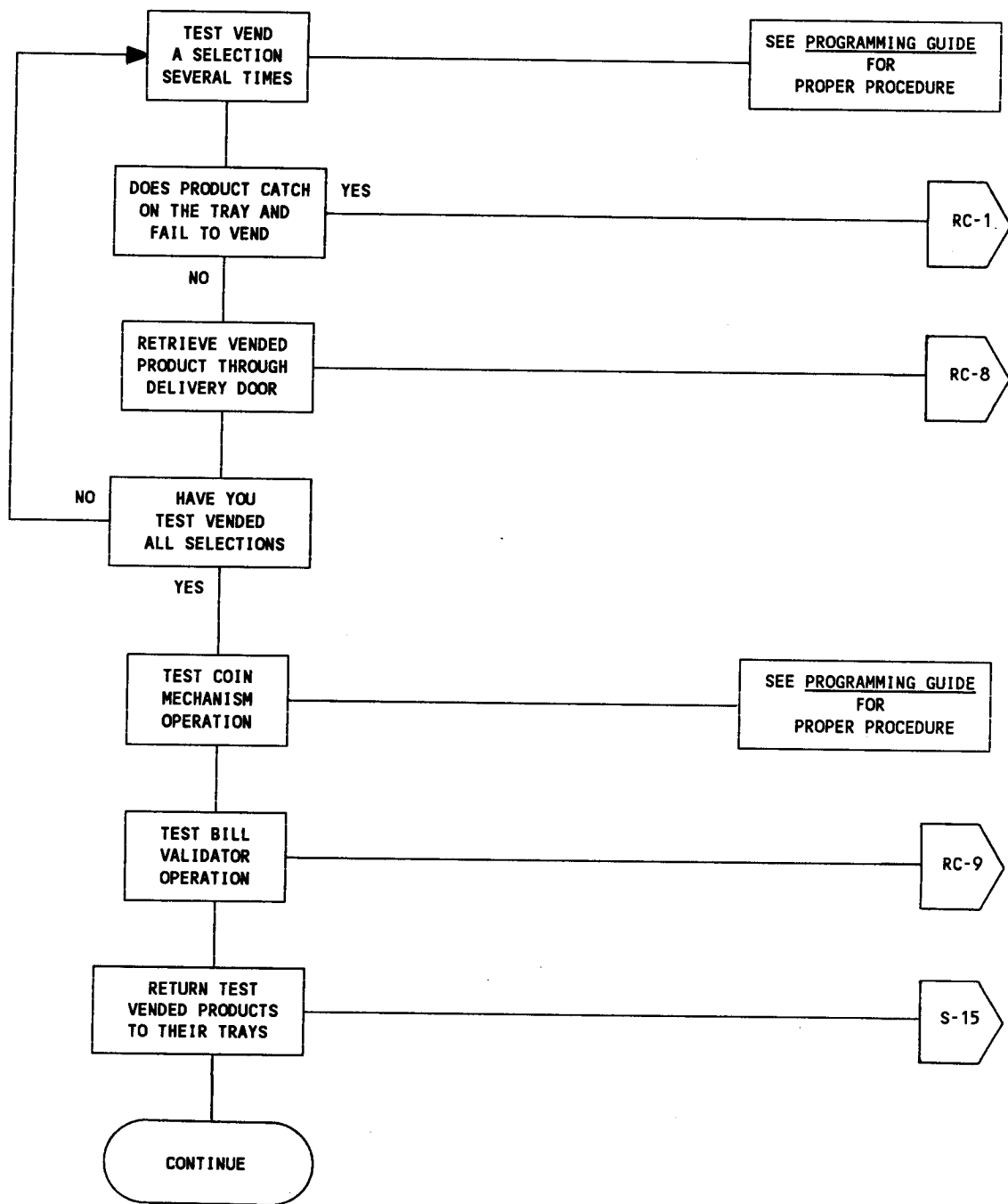

ANTI HANG-UP PROCEDURES FOR FINE TUNING SPIRALS

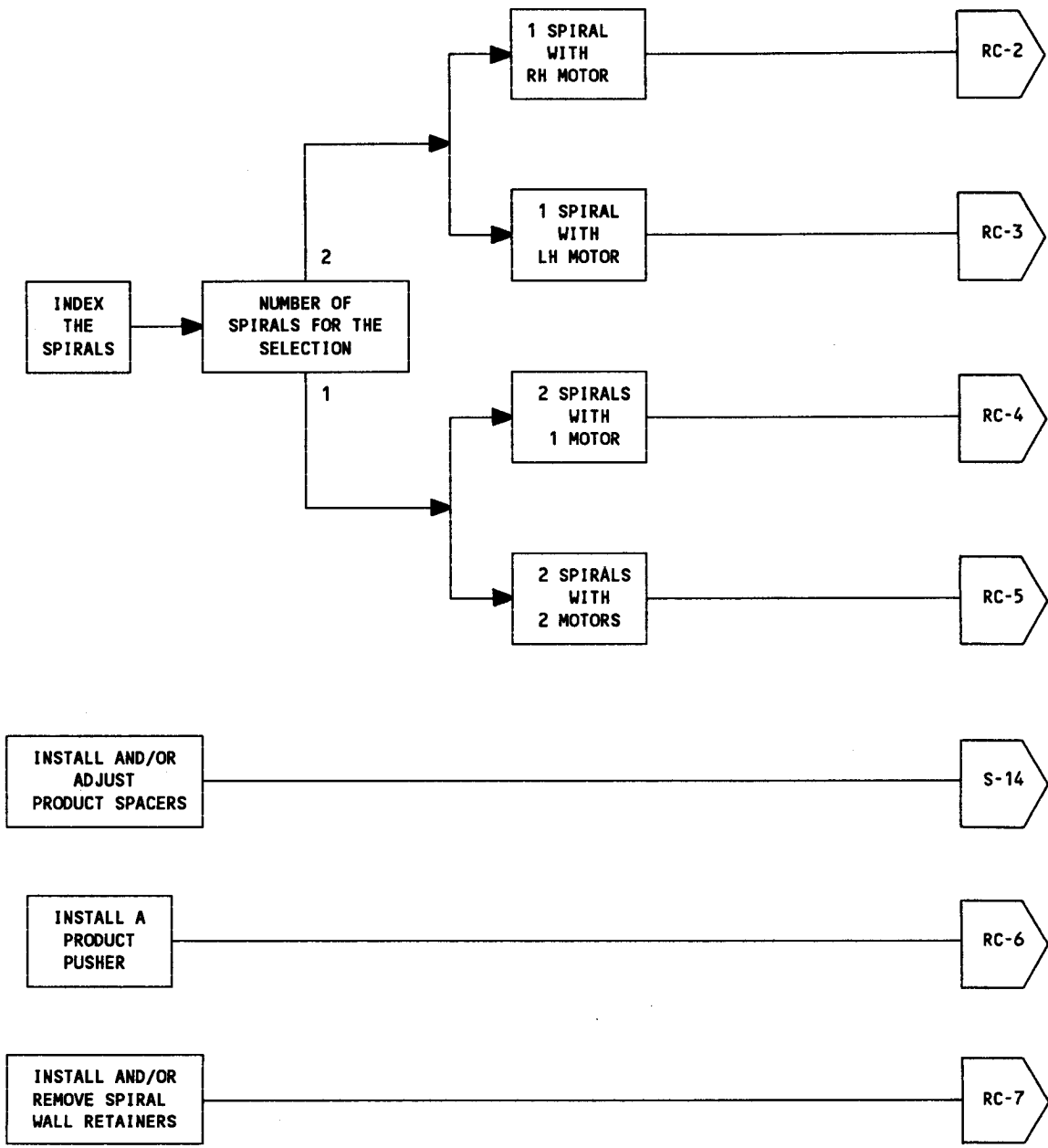

* Work with these procedures individually and in various combinations. If you are not able to eliminate a hang-up, contact National Vendors Service Department for help.

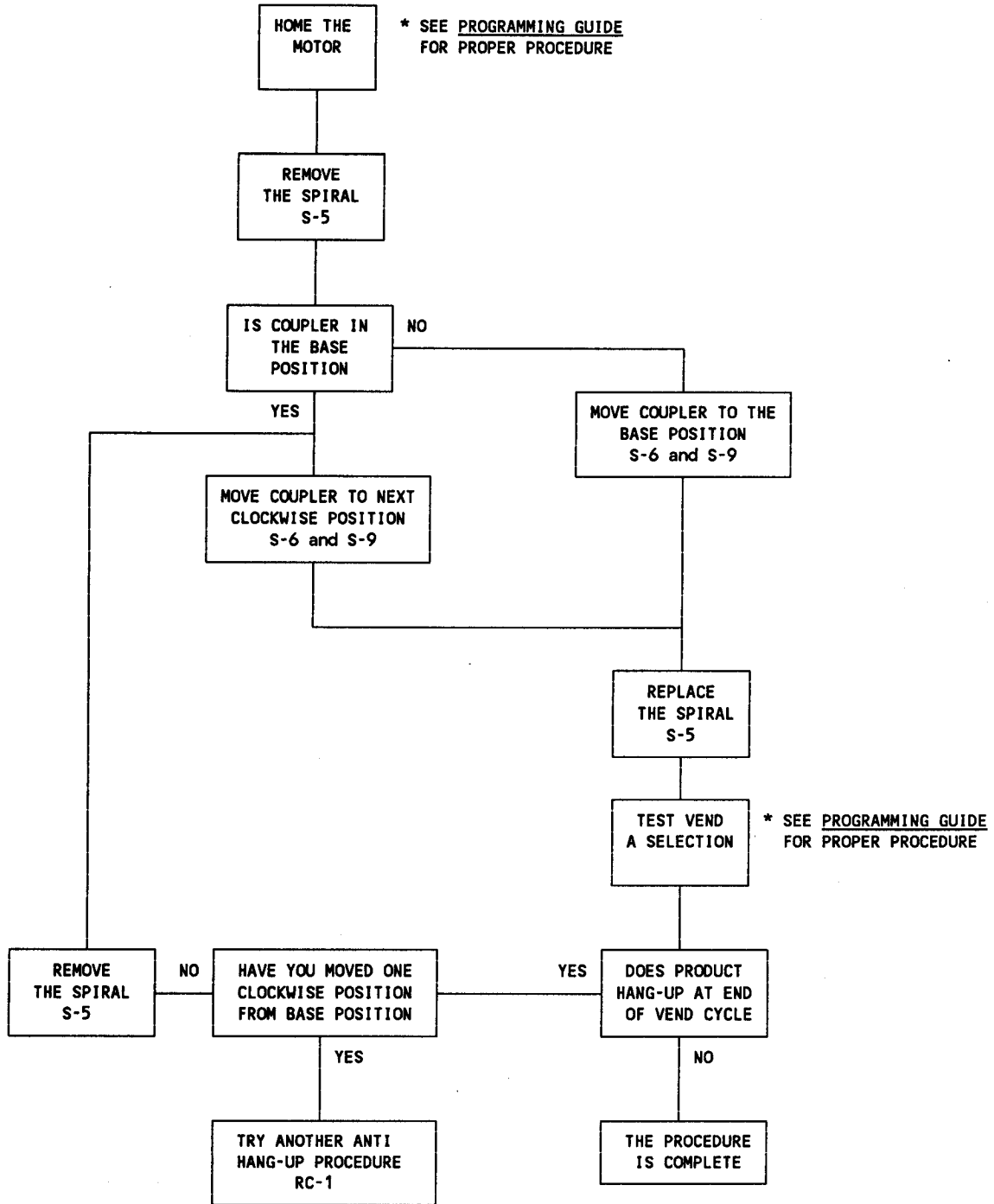

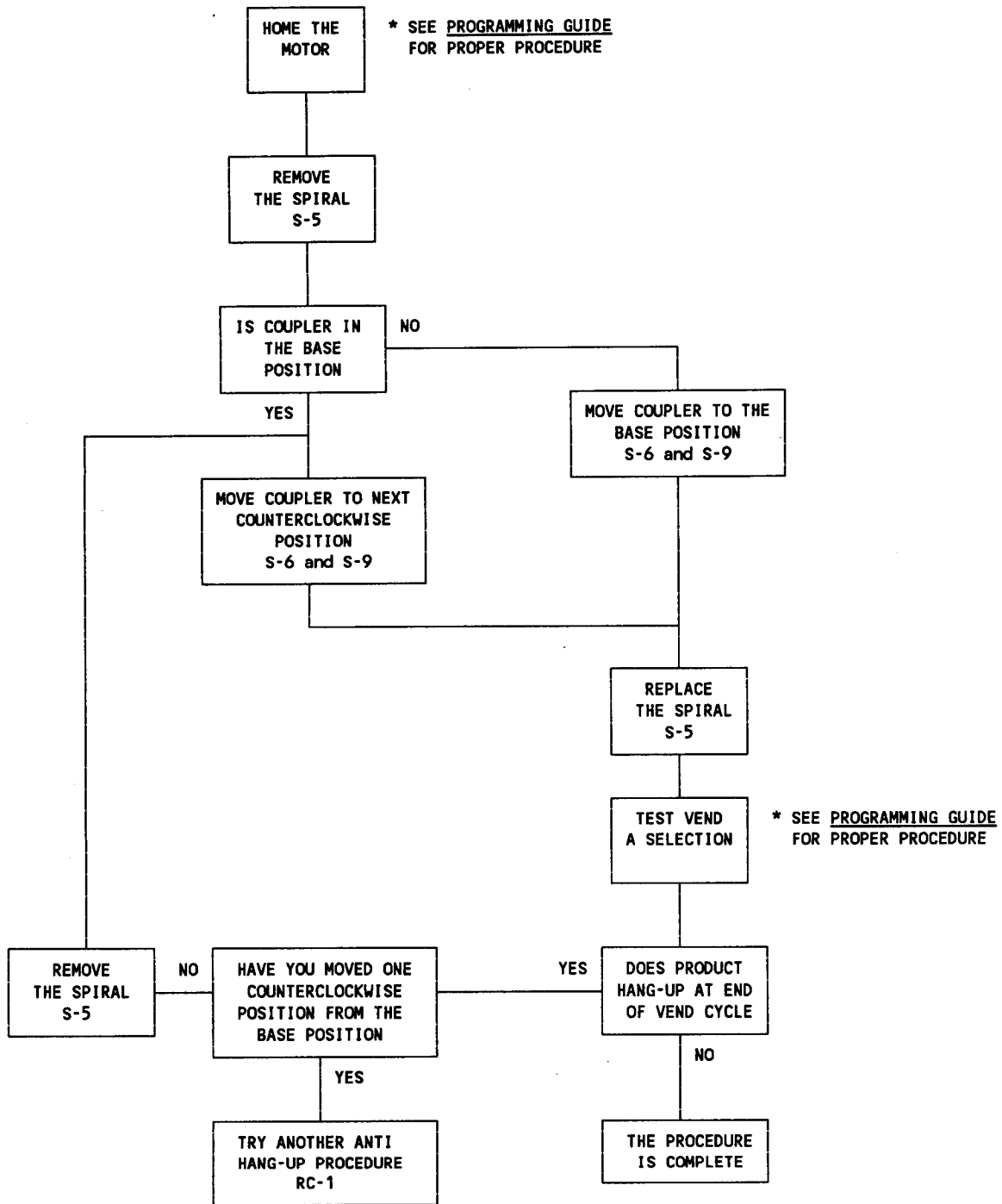

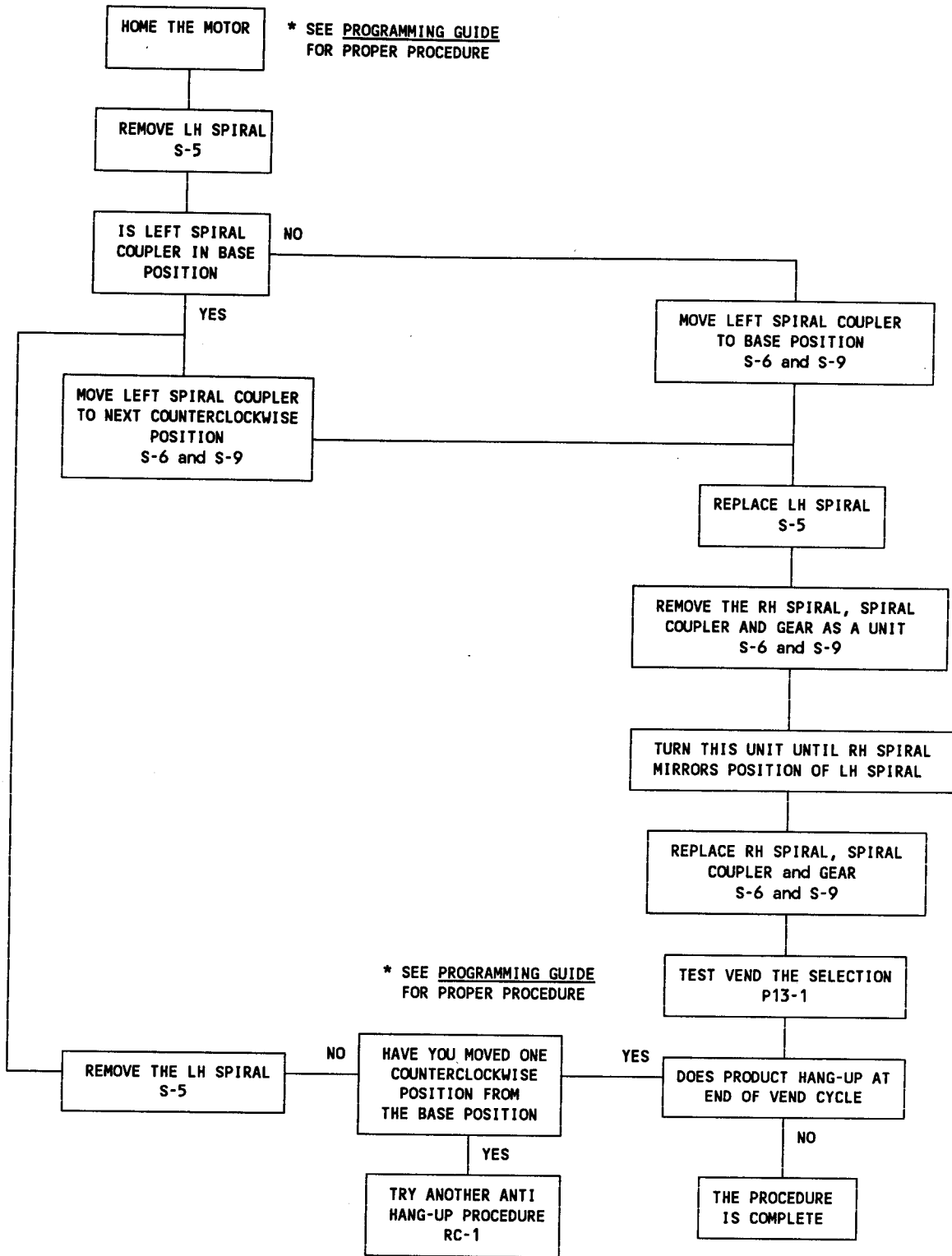

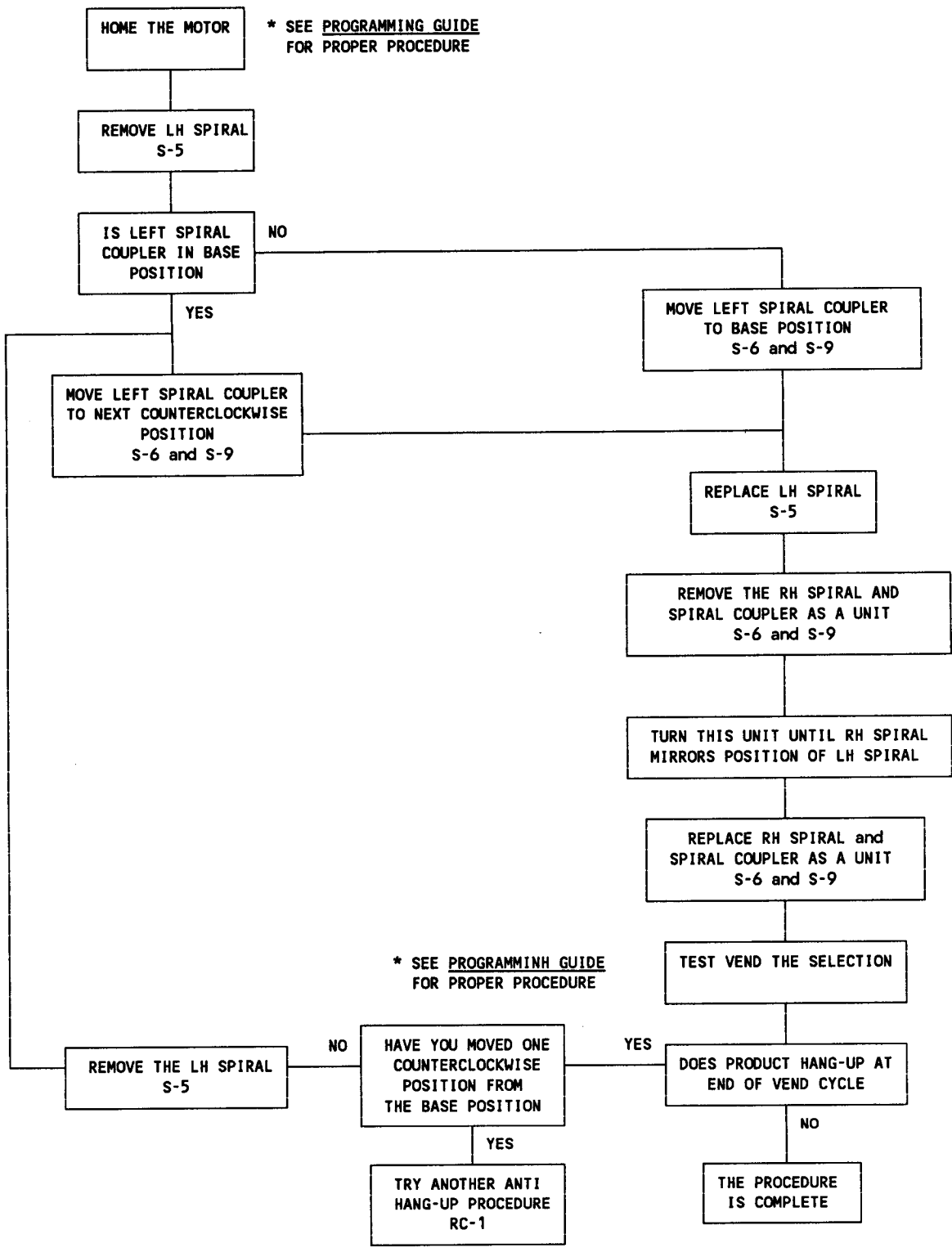

* A Product Pusher is normally used in the following cases:

- The spiral has a capacity of 15, 13 or 11
- The package is non-rigid like bagged peanuts

* The Product Pusher can also be used with other spirals and types of products.

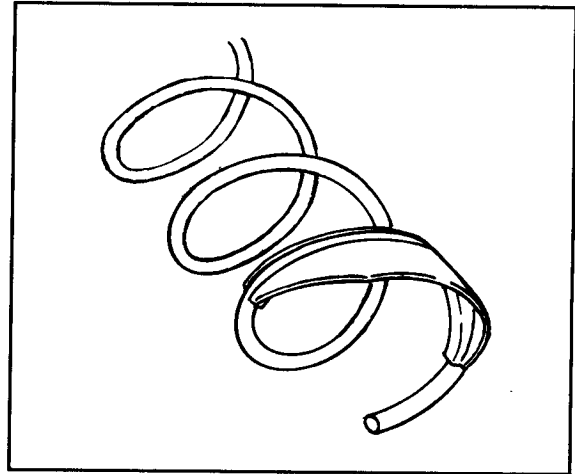

- * A bag of Product Pushers has been shipped with the merchandiser. Additional product pushers are available from National Vendors Parts Department.
- * Snap the Product Pusher on the Spiral as shown above.
- * Test Vend the selection.
- * If the product still hangs up, reposition the product pusher or try another anti hang-up procedure.

* A Spiral Wall Retainer is normally used in the following cases:

- The spiral has a capacity of 20, 25, 30 or 38.
- The product is thin
- The product is on a candy tray.

* The Spiral Wall Retainer can also be used with other spirals and types of products.

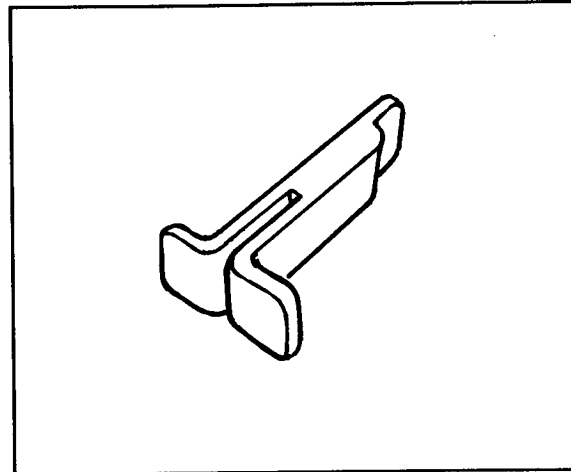

* The Spiral Wall Retainer is installed near the front of the Column Divider.

* There are two ways to install the Spiral Wall Retainer.

	RETAINER ORIENTATION	
	A	B
COLUMN DIVIDER	0 and 1	1 and 2
BETWEEN THESE POSITIONS	2 and 3	3 and 4
	4 and 5	5 and 6
	6 and 7	7 and 8
	8 and 9	

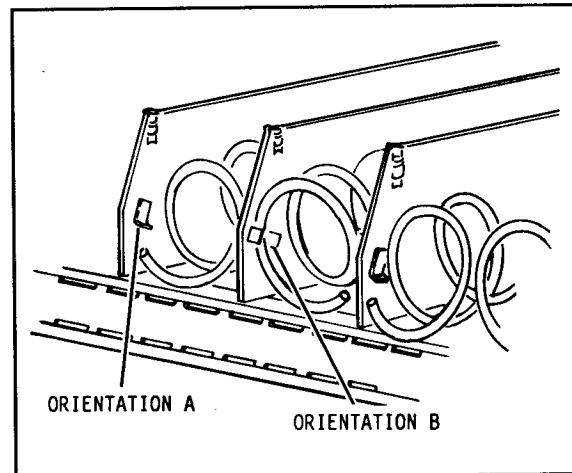

* To install a Spiral Wall Retainer, insert the Retainer in the square slot near the front of the Column Divider.

* The Spiral Wall Retainer must be removed in two cases:

- A KIT-KAT bar loaded into either of the two right hand positions of a tray will not clear the Retainer on the Column Divider between the two positions.
- A Product Pusher will catch on a Retainer in *ORIENTATION A*.

RC-8 RETRIEVING PRODUCT THROUGH THE DELIVERY DOOR

* When a product is dispensed, it will fall into the delivery pan.

* Push inward on the delivery door with one hand and retrieve the product with your other hand.



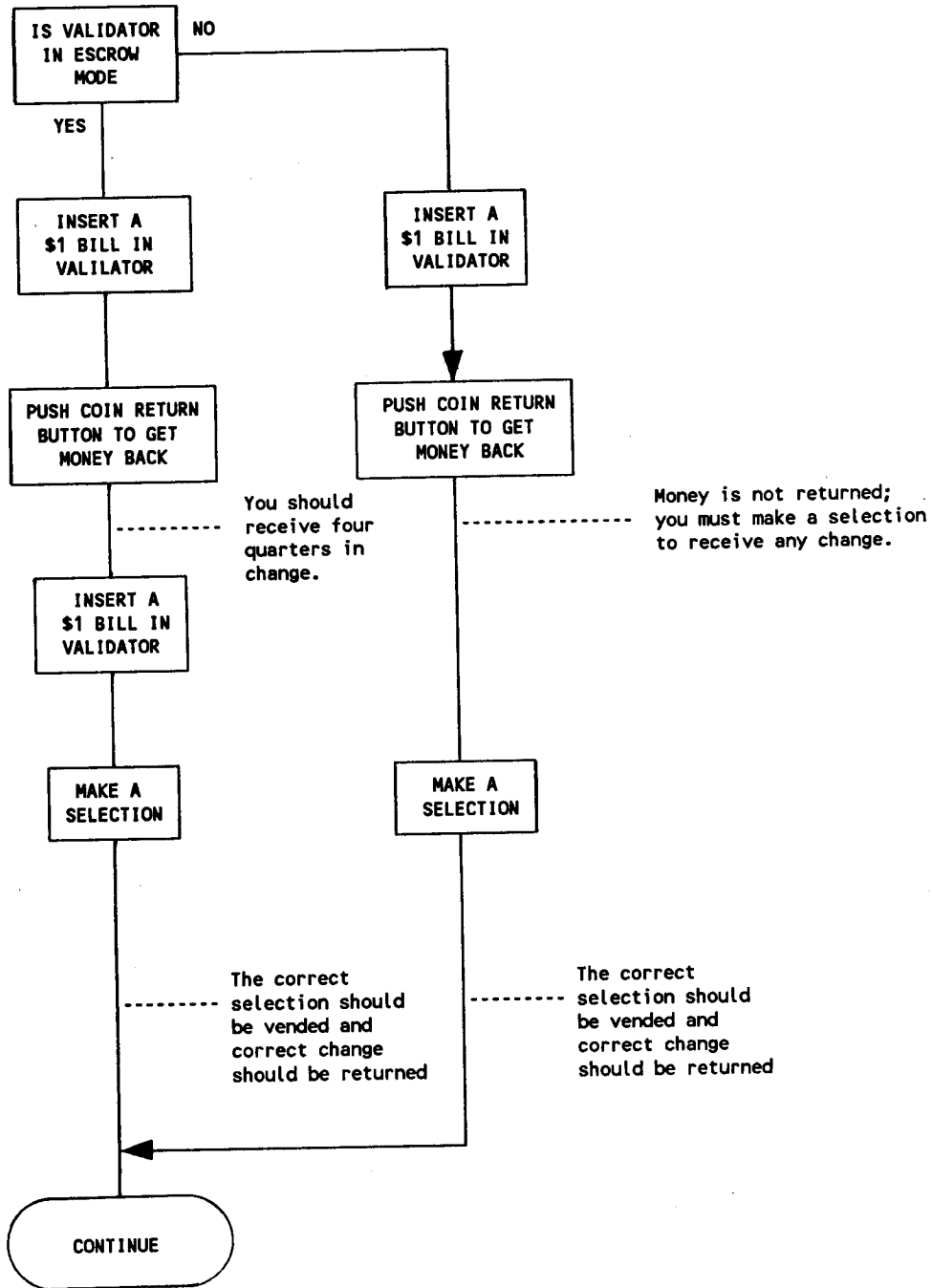

The information in this part of the manual has been provided to help you maintain this merchandiser on a day-to-day basis.

ROUTINE MAINTENANCE AND SERVICE PROCEDURES

- M-1 Removing and Replacing the 3/4 amp Fuse
- M-2 Installing the Optional Cash Box Lock
- M-3 Removal and Replacement of the Cash Box
- M-4 Replacing the Fluorescent Lamp Starter
- M-5 Replacing the Fluorescent Lamp
- M-6 Installing the Optional Exhaust Fan
- M-7 *RESERVED FOR FUTURE USE*
- M-8 Lubrication
- M-9 Cleaning the Merchandiser

Wiring Diagram - SNACK CENTER 1
Schematic Diagram - SNACK CENTER 1

**A CLEAN
AND
WELL MAINTAINED MERCHANDISER
IS THE MOST PROFITABLE MERCHANDISER**

REMOVING AND REPLACING THE 3/4 AMP FUSE

- * The 3/4 amp fuse is located on the power panel behind the monetary door.

CAUTION

Turn the Main Power Switch to the OFF position before removing or replacing the fuse.

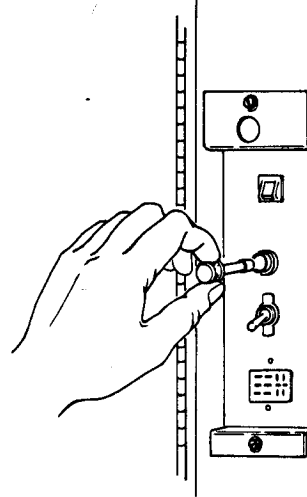

REMOVING THE FUSE:

- * Push in on the fuse-holder cap and turn counter-clockwise 90 degrees.
- * Pull the fuse out of the holder and pull it out of the fuse-holder cap.

INSTALLING THE FUSE:

- * Insert one end of the new fuse in the fuse-holder cap.
- * Insert the other end of the fuse in the fuse holder.
- * Align the tabs on the fuse-holder cap with the channels in the fuse holder, push in and turn clockwise 90 degrees.
- * Turn the Main Power Switch to the ON position.

INSTALLING THE OPTIONAL CASH BOX LOCK

- * Remove the cash box from the merchandiser.
- * Assemble the lock as shown in the illustration to the right.
- * Return the cash box to the merchandiser.

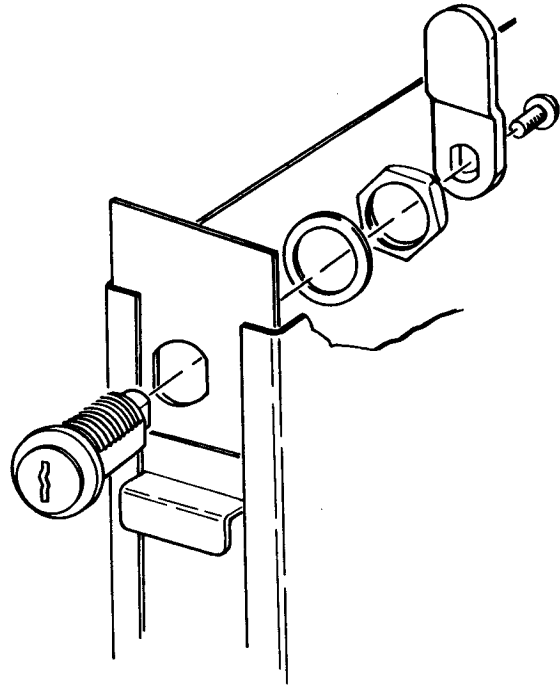

REMOVAL AND REPLACEMENT OF CASH BOX

- * The cash box is located in the lower right-hand corner of the merchandiser near the front.
- * If the cash box has a lock, you will need to unlock it first.
- * Pull the cash box forward to remove it from the merchandiser.
- * Reverse the procedure when replacing the cash box.

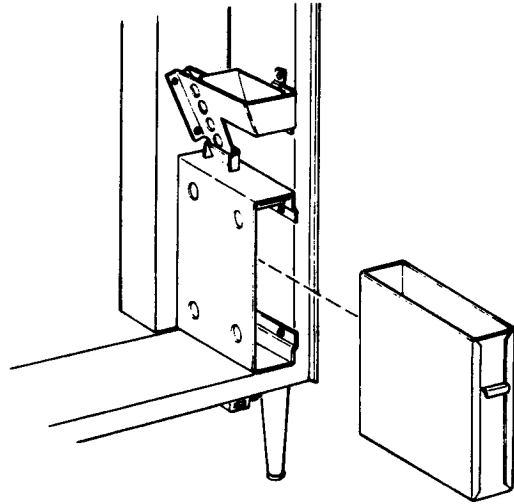
**REPLACING THE FLUORESCENT LAMP STARTER**

- * The starter is mounted on the left end of the lamp assembly.

REMOVING THE STARTER

- * Turn the starter counter-clockwise to unseat it from the socket.

INSTALLING THE STARTER

- * Insert the starter and turn it clockwise to seat it in the socket.

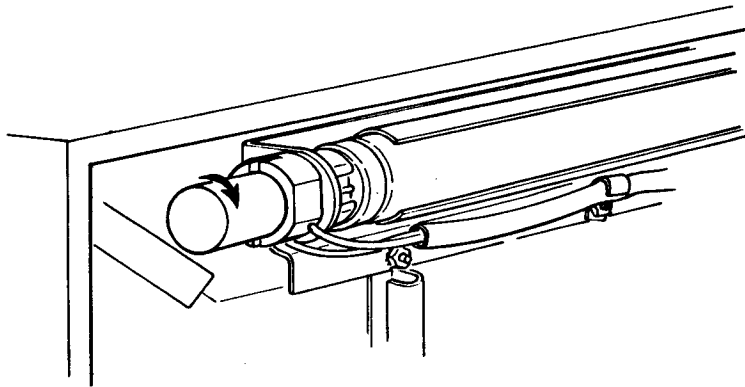

REPLACING THE FLUORESCENT LAMP

* The fluorescent lamp is mounted on the inside of the cabinet door near the top.

REMOVING THE FLUORESCENT LAMP

* Hold the lamp as shown below and turn it to remove it from the lamp sockets.

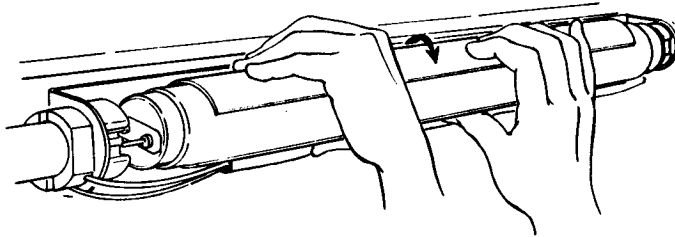

WARNING

Exercise care when you remove or replace the lamp diffuser. Eye protection should be worn during this procedure.

* Carefully slide the lamp out of the diffuser.

INSTALLING THE FLUORESCENT LAMP

* The diffuser should be positioned on the lamp as shown in the illustration on the right.

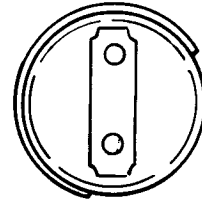

* Carefully slide the fluorescent lamp into the diffuser as shown in the illustration below.

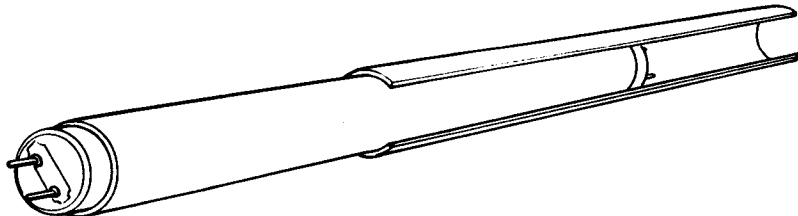

INSTALLING THE OPTIONAL EXHAUST FAN

- * There is a vent screen at the top of the right-hand, rear tray-guide mounting channel.
- * The exhaust fan will be mounted over this vent screen. See Figure M-6a.
- * Turn the Main Power Switch to the OFF position.
- * Remove the trays from the merchandiser. See S-3.
- * Remove the screw that secures the cable clamp above the vent screen assembly.
- * Remove the lower screw that secures the vent screen assembly.
- * There is a tab on the top of the vent screen assembly. Hook the small, square hole in the back of the fan mounting over this tab.
- * Secure the fan mounting bracket and the vent screen assembly. Use the screw previously removed.
- * Connect the fan to one end of the jumper that is supplied with the fan.
- * Connect the other end of the jumper to the mating connector in the power harness. See Figure M-6b.
- * Secure the cable clamp above the fan with the screw previously removed.
- * Replace the trays. See S-10.
- * Turn the Main Power Switch to the ON position.

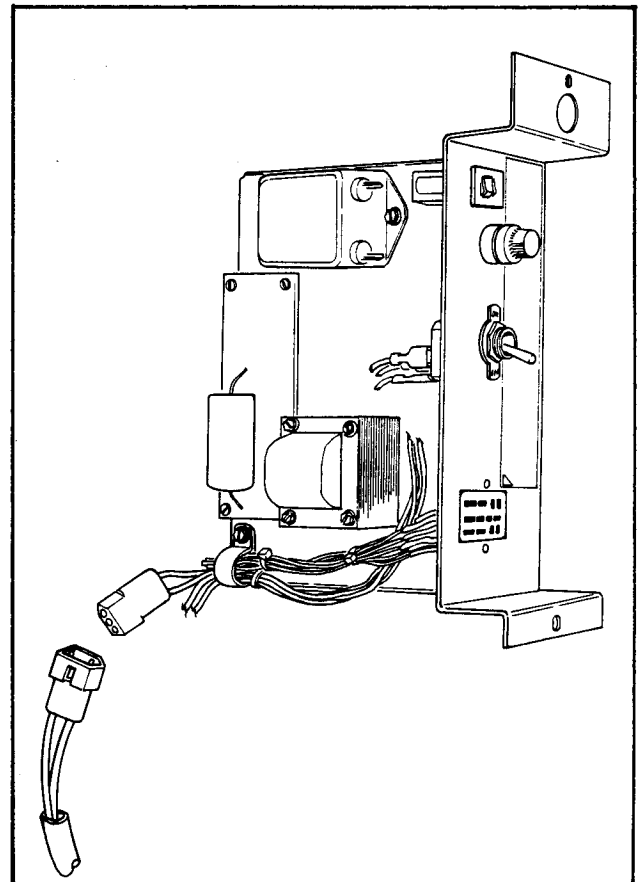
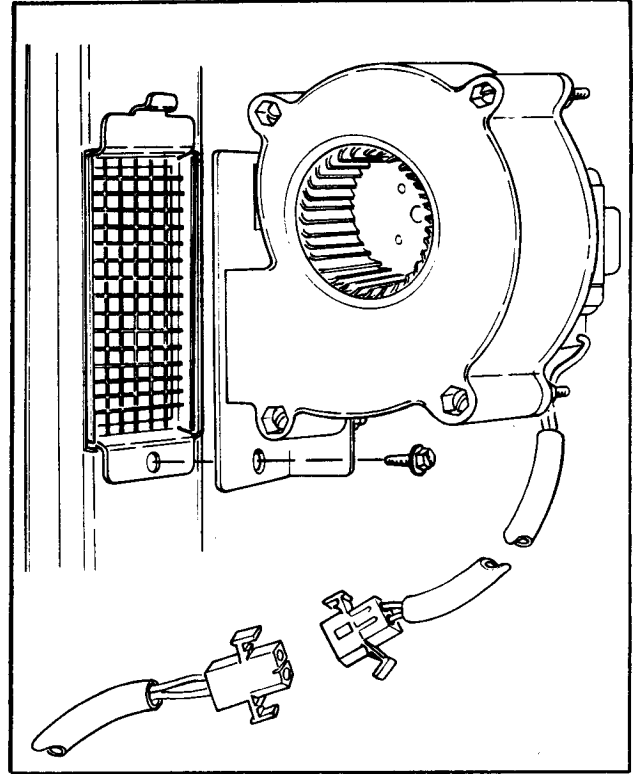

Lined writing area with 25 horizontal lines.

LUBRICATION

- * Permanent lubrication has been incorporated in the SNACK CENTER whenever practical.
 - * The Door Check and the Lock Bar assemblies are two exceptions. See Figure 1 in the Installation Section of the manual for locations of these assemblies.
 - * Lubriplate or a similar product should be used in these areas.
 - * Whenever lubrication does become necessary in other areas, *DO NOT* use a silicone based product. A silicone based lubricant can cause electrical failures.
-

CLEANING THE MERCHANDISER

- * National Vendors recommends using the following cleaning supplies:
 - Use a commercial glass cleaner on the glass in the cabinet door
 - Use a mild detergent and warm water on the cabinet, trays, spirals, gum & mint assembly and other *non-electrical* components

CAUTION

The plastic components in this merchandiser should be cleaned with a mild detergent and warm water. The use of other cleaning agents may damage the material and should be avoided.