

4550001

Model 455



Frozen

Gourmet

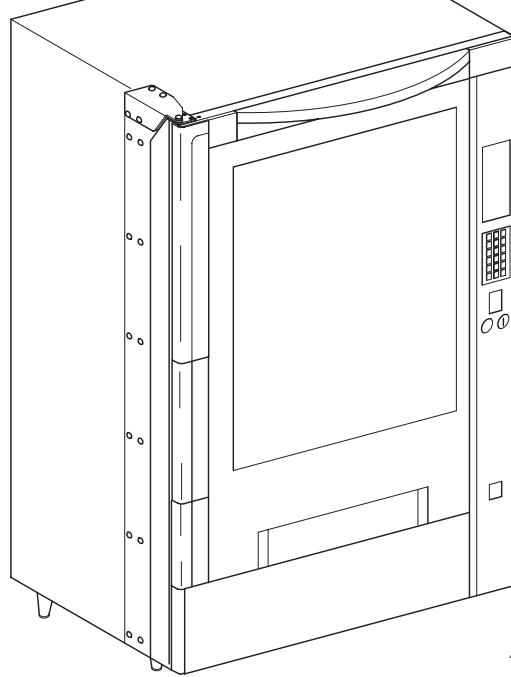

455cover

Set-Up & Operators' Guide

CRANE MERCHANDISING SYSTEMS A Crane Co. Company
NATIONAL VENDORS

12955 Enterprise Way
Bridgeton, Missouri 63044-1200
(314) 298-3500
www.nationalvendors.com

4550001

This machine has been engineered to our own rigid safety and performance standards. It has been designed to comply with sanitation and health guidelines recommended by the Automatic Merchandising Health-Industry Council (AMHIC) and it conforms with all other NAMA safety recommendations.

This machine has been manufactured in accordance with the safety standards of both Underwriter's Laboratories and the Canadian Standards Association. To maintain this degree of safety and to continue to achieve the level of performance built into this machine, it is important that installation and maintenance be performed so as to not alter the original construction or wiring and that replacement parts are as specified in the Parts Manual. Your investment in this equipment will be protected by using this Setup and Operator's Guide, the Programming Guide, and the Parts Manual in your operation, service and maintenance work. By following prescribed procedures, machine performance and safety will be preserved.

***Crane Merchandising Systems Parts and Support
Phone Numbers:***

Parts: 1-800-621-7278

Service: 1-800-628-8363

Table of Contents

Power Requirements.....	1
Specifications	1
SureVend™ System	2
Unpack and Inspect	3
Position the Merchandiser	3
Controls and Indicators.....	4
How to Turn the Merchandiser On and Off	6
Health Control	6
Loading the Merchandiser.....	7
Place trays in the loading position:	7
Set Up Trays to Vend Products	8
Removing a Tray	8
Remove a Column Divider.....	9
Operate a Tray Outside the Machine.....	10
Changing Tray Configurations	11
Replacing a Motor With a Spiral Bearing.....	11
Connecting and Disconnecting a Motor Harness	11
Set Up a Tray to Vend Wide Products	12
Removing and Installing Spirals	14
Removing and Installing a Spiral Motor:.....	16
Installing a Gear	17
Installing a Spiral Coupler.....	18
Moving a Tray Up or Down	19
Installing a Tray in the Merchandiser	20
Load Trays With Product	21
Loading a Tray With Products In General:	21
Product Pusher Usage:	22
Return the Trays to the Vending Position	23
Install and Set Price Labels	24
Installing Price Labels:.....	24
Adjusting the price roll:.....	24
Install Selection ID Labels	25
Installing Selection ID Numbers:.....	25
Which ID Label Goes With Which Selection?	26
Refrigeration System	27
Screens:	27
Spacing:.....	27

Frozen Gourmet Setup and Operators' Guide

Accessories	28
Install the Lock Cylinder:	28
Install the Optional Cash Box Lock:	28
Load the Coin Mechanism:	28
Basic Programming	29
Set Prices	29
View the Cabinet Temperature	30
View the Evaporator Temperature	30
Freezer Defrost	30
Final Checkout.....	31
Test Vend Selections	31
Operational Readiness Check.....	31
Spiral Indexing Procedure (One Spiral, One Motor)	32
Spiral Indexing Procedure (Two Spirals, One Or Two Motors)	33
Testing the Bill Validator	33
Routine Service and Sanitation	34

Frozen Gourmet Setup and Operators' Guide

Thank you for purchasing a Crane Merchandising Systems Frozen Gourmet vending machine. Your vending machine is actually a freezer, a refrigerator, and can be operated in a “slack” or “soft freeze” mode.

See your Programming Guide for details.

OPERATION AS A FROZEN VENDING MACHINE:

The frozen gourmet has a setpoint range of -3° F to -10° F. The default and recommended setting from the factory is -5° F. The defrost cycle default setting from the factory is 4 cycles per 24 hour period. The operator may adjust the number of defrost cycles per 24 hour period from a minimum of 1 to a maximum of 8.

See your Programming Guide for details.

OPERATION AS A SLACK OR SOFT FROZEN VENDING MACHINE:

The frozen gourmet has a setpoint range of +12° F to 0° F. The recommended setting for this zone is +6° F. The defrost cycle default setting from the factory is 4 cycles per 24 hour period. The operator may adjust the number of defrost cycles per 24 hour period from a minimum of 1 to a maximum of 8.

See your Programming Guide for details.

OPERATION AS A REFRIGERATED VENDING MACHINE:

The frozen gourmet has a setpoint range of +34° F to +38° F. The recommended setting for this zone is +37° F. The defrost cycle default setting from the factory is 4 cycles per 24 hour period. The operator may adjust the number of defrost cycles per 24 hour period from a minimum of 1 to a maximum of 8.

See your Programming Guide for details.

NOTES:

Frozen Gourmet Setup and Operators' Guide

CAUTION

Do not connect the machine power cord or attempt to operate the merchandiser before it is completely inspected, and your location's power supply is checked for proper voltage and grounding as outlined below.

Power Requirements

The merchandiser is supplied with a service cord for the country of use and is terminated in a grounding type plug. The wall receptacle used for this merchandiser must be properly polarized, grounded, of the correct voltage, and rated for outdoor use. Operating the merchandiser from a source of low voltage will **VOID YOUR WARRANTY**. Each merchandiser should have its own electrical circuit and that circuit should be protected with a circuit breaker or fuse conforming to local regulations.

Voltage Check - Place the leads of a voltmeter across the LINE (LIVE) and NEUTRAL terminals of the wall receptacle. The voltmeter should indicate 110-130 volts ac for 120 volt, 60 Hz locations.

Polarity Check - Place the leads of a voltmeter across the LINE (LIVE) and GROUND terminals of the wall receptacle. The voltmeter should indicate 110-130 volts ac for 120 volt, 60 Hz locations.

Noise Potential Check - Place the test leads of a voltmeter across the NEUTRAL and GROUND terminals of the wall receptacle. The meter should indicate 0 volts ac. A measurement greater than 1.5 - 2.0 volts ac could result in problems for the merchandiser's electronic circuitry caused by electrical noise.

Any deviation from these requirements could result in unreliable performance from your merchandiser.

FOLLOW ALL LOCAL AND NATIONAL CODES

Specifications

Dimensions	
Height	72" (1829 mm)
Width	48 3/8" (1229 mm)
Depth	36.5" (Millennia Style) (927 mm)
Shipping Weight	881 lbs. (400 kg) (without packing material)
Circuit Requirements	20 Amp circuit
Refrigeration:	
Refrigerant	R-404a
Charge	461g (16.25 oz.)
Compressor	3/4 hp.

Frozen Gourmet Setup and Operators' Guide

SureVend™ System



- **Guaranteed delivery eliminates credit vouchers due to misloading or product hang-ups**
- **Credit is reestablished if product is not delivered, or can be configured to refund customer's money**
- **Spirals return to home for best visual product presentation**
- **Machine automatically returns to standard operation if a SureVend™ problem is detected - no machine downtime**
- **Feature is standard on this machine**
- **Automatic self-calibration - no adjustment is necessary**
- **Works in all lighting conditions and temperatures**
- **Retrofit kit is available for most recent model spiral equipment**

Frozen Gourmet Setup and Operators' Guide

Unpack and Inspect

Verify the model and part numbers with the merchandiser invoice or freight bill. Immediately report any shortage or discrepancy to the carrier.

Remove and save all shipping and packing materials until a thorough inspection has been completed.

Examine the merchandiser for dents, scratches, or other damage resulting from improper handling. If any shipping damage is detected, file an immediate claim with the carrier.

Position the Merchandiser

WARNING

This machine is only rated for installation in an indoor location.

1. Place the merchandiser in its final location. Make sure there is a minimum of 6 inches between the rear screen and the wall.
2. Level the merchandiser:
 - a. Place a spirit level on the top front edge of the cabinet with the door fully closed. Adjust the front legs only until the cabinet is reasonably level.
 - b. Hold the door open about 4 inches.

WARNING

Have an assistant hold the merchandiser while you adjust the leg levelers.

- c. Adjust the back legs so that the back leg leveler on the hinge side is off the floor just enough so a piece of paper can slide under it with only a bit of resistance.
- d. For proper weight distribution on all four legs, raise the back leg on the hinge side by unscrewing the leveler 1½ turns.

NOTE

You may need to use pliers or channel locks to loosen the leg levelers.

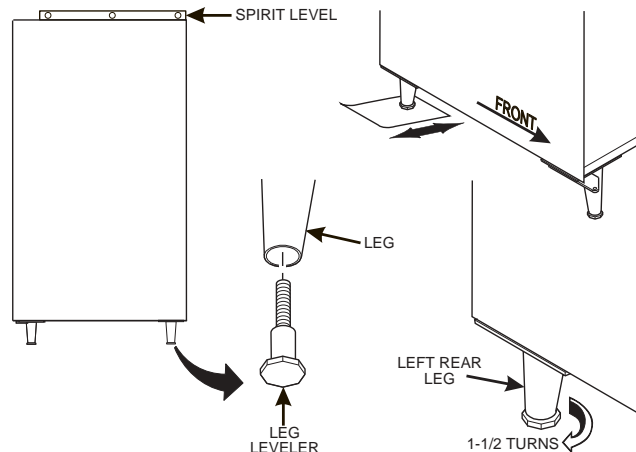

3. Plug the merchandiser into a wall receptacle.

Frozen Gourmet Setup and Operators' Guide

Controls and Indicators

Interlock Switch. When the cabinet door is open, this switch turns off the glass heater and turns on the service light (not present on all models).

Low Voltage Switch. Informs the controller software of the main door open or closed status.

Message Display. This is how the merchandiser communicates with the outside world. Customers can see messages about how much money they have put into the merchandiser. The message display also tells customers when a selection is sold out and when vending is free, inhibited, or discounted. The message display shows you what you are doing when you program the merchandiser, and can show you what is wrong if there is a failure.

Free Vend Keyswitch (optional). This allows someone (other than maintenance people) to set the merchandiser to free vend without opening the door.

Selection Switch Panel. The customer uses these switches to make selections. Also, maintenance people may use this switch panel during programming and other support modes.

Coin Return Button. Pressing this button returns any coins that have been paid into the merchandiser prior to a vend.

Bill Acceptor (Optional). Accepts bills in various denominations, depending upon the type of bill validator, and how the machine is configured.

Service Keypad. The service keypad is located at the top of the monetary panel. It gives service personnel the means to program, retrieve data from, and view diagnostic information about the merchandiser.

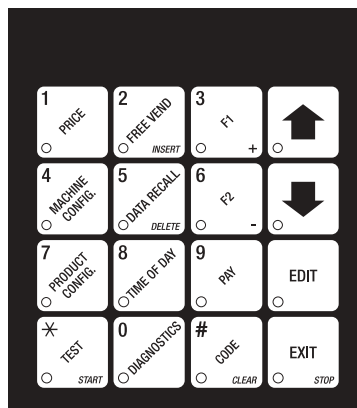

Frozen Gourmet Setup and Operators' Guide

Controls and Indicators (Continued)

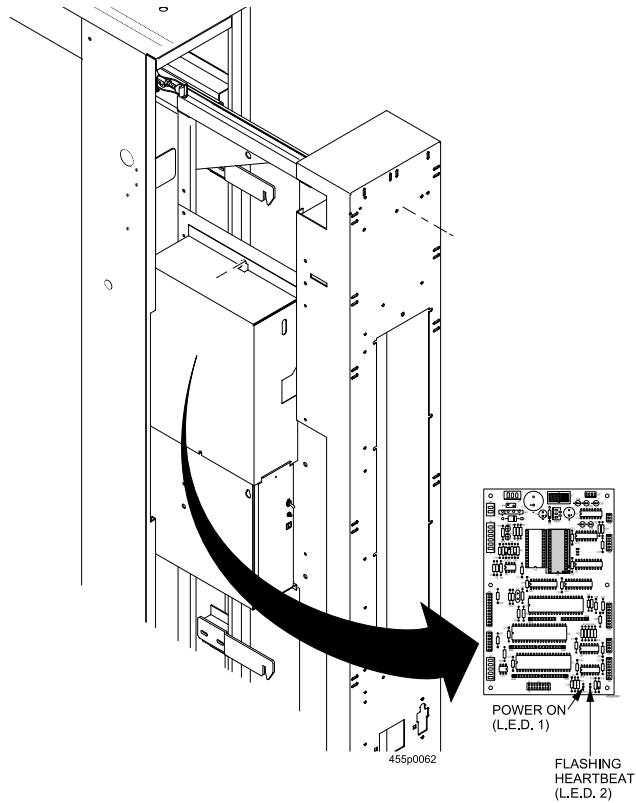

Main Controller PCB Display. This display consists of two light emitting diodes (LED) mounted on the controller PCB.

POWER ON
(L.E.D. 1)

When lit, this red LED indicates electrical power is applied to the controller PCB.

HEARTBEAT
(L.E.D. 2)

When flashing, this red LED indicates that the controller PCB is active, and the software is operating.

NORMAL CONDITIONS:

When the merchandiser is operating normally, you should see a steady red **POWER ON** indicator and a flashing red **HEARTBEAT** indicator. Contact a service representative if any other condition exists.

Frozen Gourmet Setup and Operators' Guide

How to Turn the Merchandiser On and Off

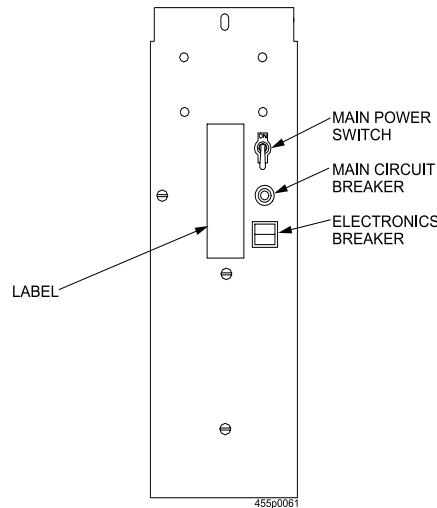

- Power to the merchandiser is controlled by the main power switch, located on the power panel.
- The power panel is on the right side of the merchandiser, behind the monetary door.

WARNING

Lethal voltages are present. Unplug the merchandiser whenever you do one of the following tasks:

- Change a fuse
- Change the fluorescent lamp
- Change the lamp starter
- Connect or disconnect a harness (except a motor harness when the tray has been removed)

Failure to do so may result in personal injury.

Health Control

The Frozen Gourmet merchandiser is equipped with an electronic automatic shutoff (health) control as required by most state and local health authorities. This control prevents vending of merchandise when the temperature in the food storage compartment exceeds the design requirement for potentially hazardous food.

Your merchandiser is unique in that it is designed to store and dispense food product that is either frozen, slacked frozen or cold. Frozen means maintaining food at or below 0°F (-18°C).

Slacking means the process of moderating the temperature of a pre-cooked frozen food to facilitate the reheating process. Slacked frozen food is maintained at or below 15°F (9.4°C). Cold food is to be maintained at or below 41°F (5°C).

This merchandiser will automatically go out-of-service if the temperature in the food storage compartment goes above 0°F (-18°C) for frozen food, 15°F (-9.4°C) for slacked frozen food or 41°F (5°C) for more than 15 minutes. This will also occur if the temperature of the food storage compartment does not fall to 0°F (-18°C) for frozen food, 15°F (-9.4°C) for slacked frozen food within 75 minutes of the cabinet door being closed or 41°F (5°C) for cold food within 30 minutes of the door being closed.

When the Automatic Shutoff Control deactivates the vending mechanism the display will show *TEMPORARY OUT OF SERVICE*. When the monetary door is opened, the message *HC.ERR* will be displayed along with the date, time and maximum cabinet temperature reached. Should this occur, the food is to be discarded. To reset the Shutoff Control, the refrigerated cabinet door must be opened and closed again.

This out-of-service condition may occur at initial setup. Therefore, Crane Merchandising Systems recommends the merchandiser be operated with the food storage compartment empty until the temperature reaches a level low enough to satisfy the Shutoff Control.

Frozen Gourmet Setup and Operators' Guide

Loading the Merchandiser

1. Place trays in the loading position:

- a. Place both hands on the tray as shown.
- b. Lightly lift the front of the tray and pull the tray toward you until you hear and feel the rear tray rollers drop into the cut-out in the top of the guide rail.

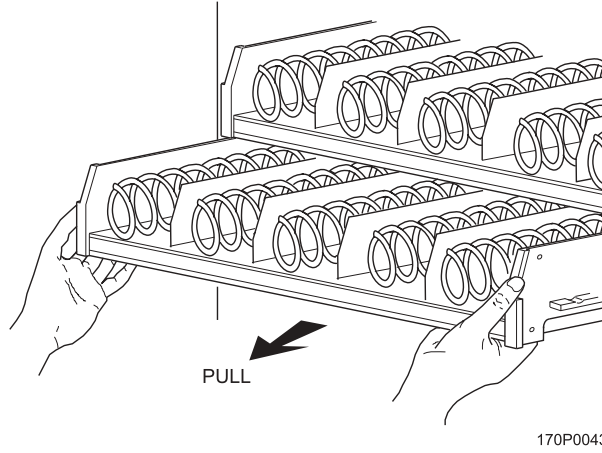

- c. Continue pulling the tray forward for another inch. You will then be able to tilt the tray downward into the loading position as shown.

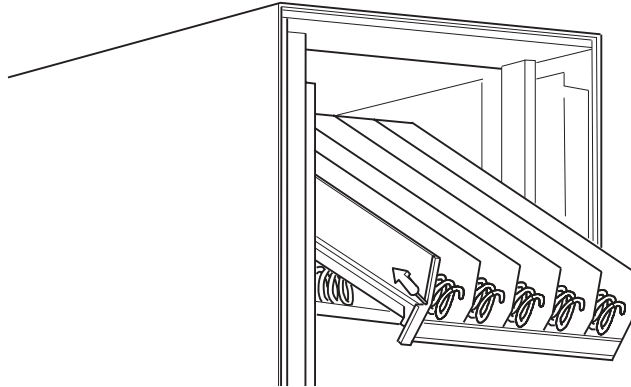

NOTE

Handle the tray with care to avoid scratching the delivery pan assembly.

Frozen Gourmet Setup and Operators' Guide

2. Set Up Trays to Vend Products

These instructions will guide you through setting up your trays for vending. You will be asked to determine if your tray can physically hold the products you intend to vend. If not, you will be directed to other procedures which will help you get them set up. Follow these steps for each tray in your machine:

- a. Make sure the tray is in the loading position.
- b. Will the products fit between the spiral turns? If so, proceed to the next step. Otherwise, change the spiral.
- c. Will the product pass under the tray immediately above? If so, proceed to the next step. Otherwise, reposition the tray and guides.
- d. Will the product touch products on either side? If not, proceed to the next step. Otherwise, install a product spacer.
- e. Load products in the tray.
- f. Return the tray to the vending position.
- g. Install the price labels.
- h. Install the selection ID numbers.

3. Removing a Tray

Study this procedure before you install a tray for the first time; while you are holding the tray you will not be able to see this area. Proceed as follows:

- a. Lightly lift the front of the tray and pull the tray toward you until you hear and feel the rear tray rollers drop into a cut-out in the top of the guide rail

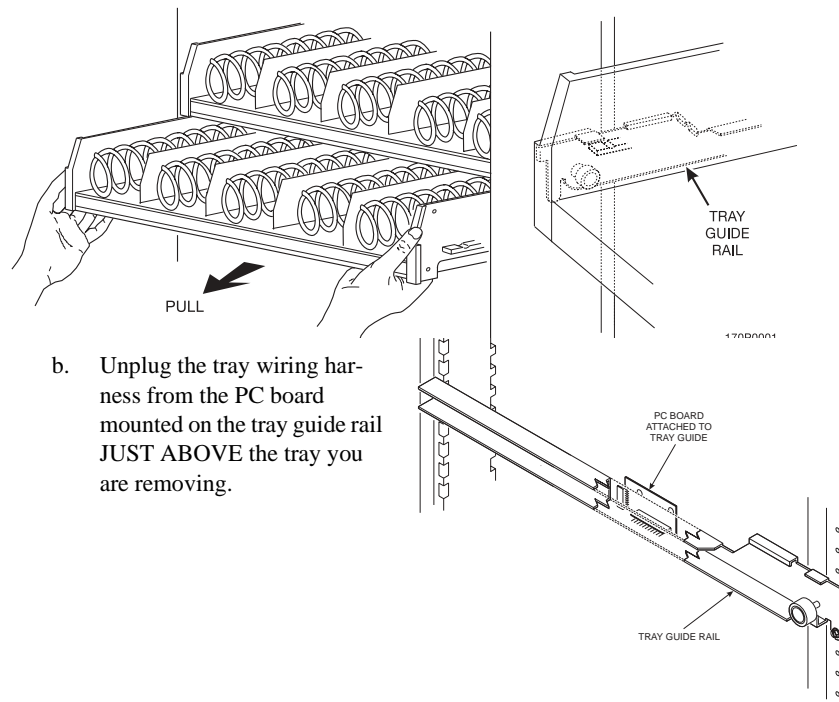

- b. Unplug the tray wiring harness from the PC board mounted on the tray guide rail **JUST ABOVE** the tray you are removing.

Frozen Gourmet Setup and Operators' Guide

- c. Lift up on the tray and slide it toward the back. No more than an inch should be needed.
- d. The tab near the back of the tray should align with the cut-out in the top of the tray guide rail as shown.
- e. Lift the tray clear of the tray guide rail and out of the merchandiser.

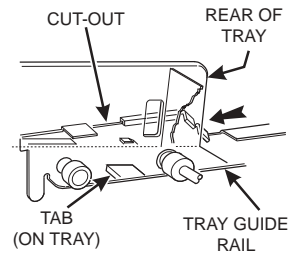

CAUTION

When the cabinet door is not fully open, use extra care in removing the bottom tray. Failure to do so may result in damage to the tray.

4. Remove a Column Divider

- a. Push the column divider toward the back of the tray - ①.
- b. Lift the column divider clear of the tray - ②.
- c. Install the column divider in the reverse order of removal.

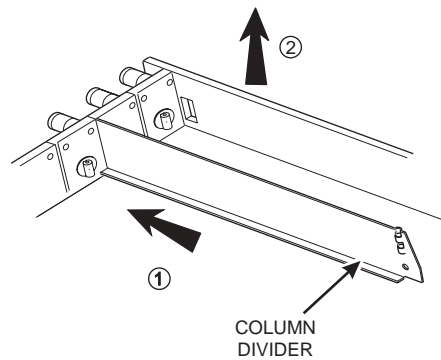

Frozen Gourmet Setup and Operators' Guide

Operate a Tray Outside the Machine

Tray harness extension (P/N 1709018) is available from your National Vendors Parts department. The extension will enable you to remove the tray from the machine and still operate the motors and spirals. Connect it as shown:

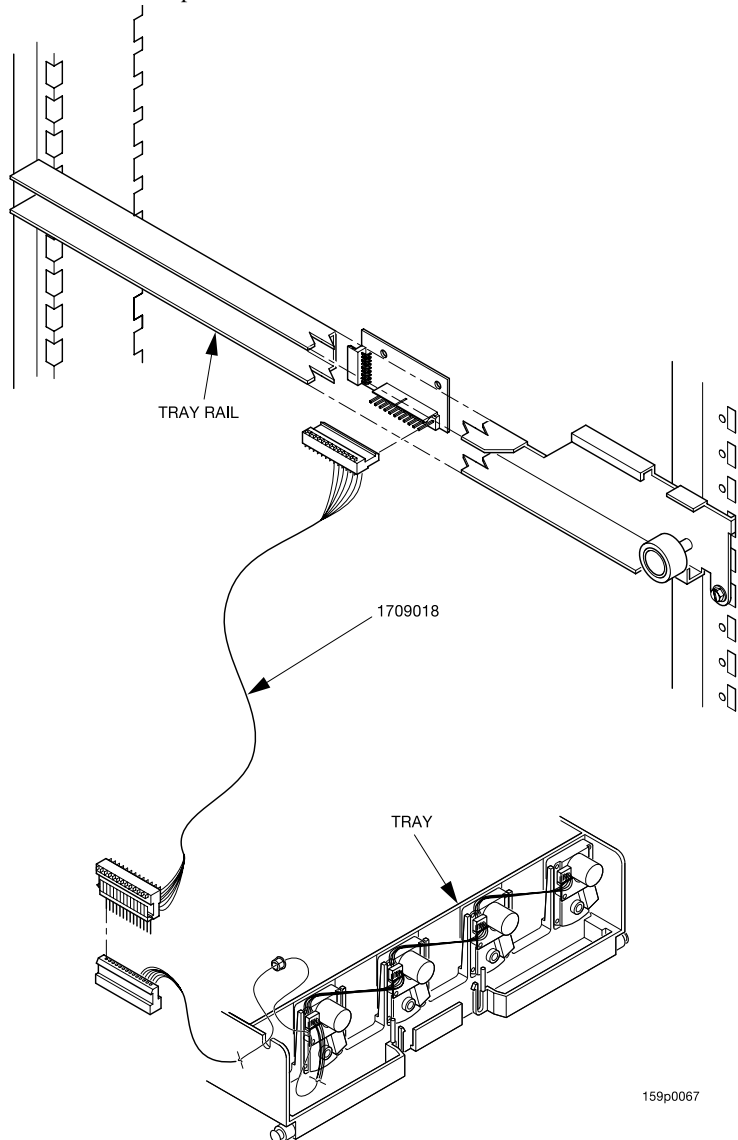

159p0067

Frozen Gourmet Setup and Operators' Guide

Changing Tray Configurations

1. Replacing a Motor With a Spiral Bearing

REMOVING A MOTOR:

- Disconnect the harness from the motor. See *CONNECTING AND DISCONNECTING A MOTOR HARNESS*, below.
- Remove the spiral. See *REMOVING AND INSTALLING SPIRALS* (page 14).
- Remove the spiral coupler. See *REMOVING A SPIRAL COUPLER* (page 15).
- Remove the motor. See *REMOVING AND INSTALLING A SPIRAL MOTOR* (page 16).

INSTALLING A SPIRAL BEARING:

- Put the gear into position if required in this set-up as shown. See *INSTALLING A GEAR* (page 17).

Install the spiral coupler. See *INSTALLING A SPIRAL COUPLER* (page 18).

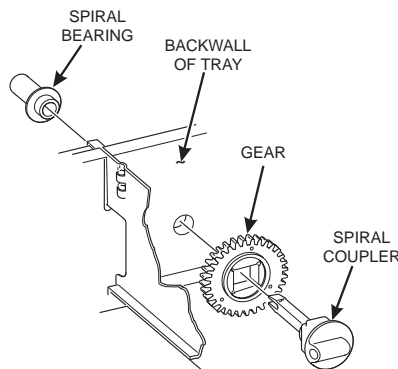

2. Connecting and Disconnecting a Motor Harness

To avoid breaking the motor circuit board, **hold the header** on the circuit board whenever connecting or disconnecting a motor harness.

DISCONNECTING A MOTOR HARNESS:

- Pull the harness connector away from the circuit board as shown.
- Tuck the unused part of the harness out of the way in the trough at the back of the tray.

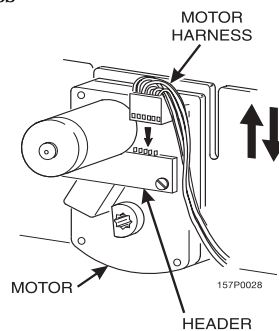

CONNECTING A MOTOR HARNESS:

- Locate the harness connector for the appropriate tray position.

Push the harness connector over the header pins on the motor circuit board as shown.

Frozen Gourmet Setup and Operators' Guide

3. Set Up a Tray to Vend Wide Products

The following steps will help you configure your tray to vend wide products. When you have completed the procedures called out in each step, return to the next step in the procedure. When you are done with the entire wide product steps, return to the set-up procedures above.

- a. Remove the tray from the merchandiser and place on a flat surface.
- b. Based on the size of the product you want to vend, decide how many spiral positions it will occupy. **Please remember that the leftmost spiral in the group must have an even ID number (0, 2, 4, etc.)** For example, if a product is three spirals wide, the left spiral will be ID number 0, and the right spiral will be ID number 2. Be careful how wide you set up for, because really wide products could get hung up in the delivery door.
- c. Remove the column dividers inside the group. See **REMOVE A COLUMN DIVIDER**, page 9. In the example of three spiral positions, you would be removing the dividers between spiral ID numbers 0 and 1, and 1 and 2.

NOTE

The left-most position in the group of three must be an even numbered position.

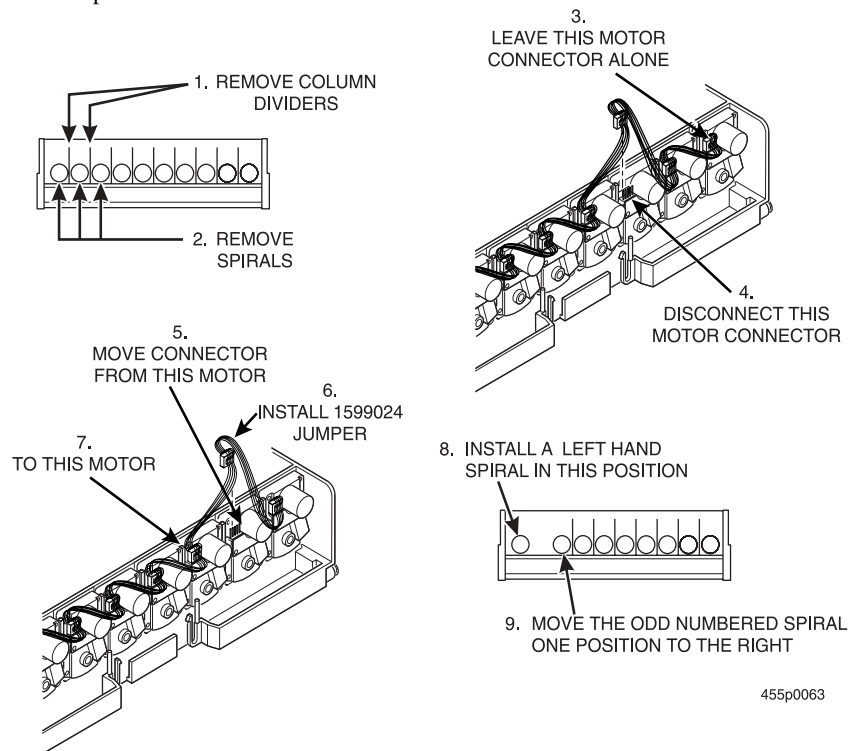

- d. If your product requires 2 adjacent spirals, replace the rightmost motor with a spiral bearing and gear, and install a gear on the leftmost motor. Skip to step h.
- e. Remove all spirals in the group except the leftmost spiral.

Frozen Gourmet Setup and Operators' Guide

- f. Do one of the following:
- If your group has an **ODD** number of spirals (3, 5, etc.) remove the harnesses from all motors in the group except the leftmost one. To the rightmost motor, utilizing the 1599024 jumper, connect the harness from the motor immediately to its left.
 - If your group has an **EVEN** number of spirals (4, 6, etc.) remove the harnesses from all motors inside the group (leave the harnesses connected to the leftmost and rightmost motors).
- g. Install a spiral at the rightmost position in your group. Make sure it has the same product capacity and is opposite to the one in the leftmost position.
- h. Return the tray to the merchandiser.
- i. Electronically couple the motors as needed (see your ***Programming Guide*** for information).

Couple the left motor to the right motor inside the frost cover over the tray motor. See the ***Programming Guide***.

Load products as shown.

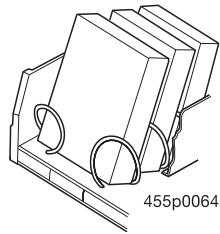

Frozen Gourmet Setup and Operators' Guide

4. Removing and Installing Spirals

All spirals are the same diameter:

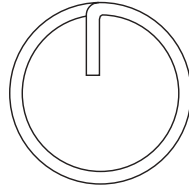

- There are two types of spirals:

COUNTER-CLOCKWISE (left hand)

CLOCKWISE (right hand)

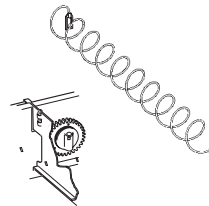
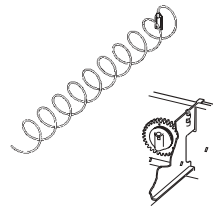

ITEM CAPACITY OF SPIRAL	PART NUMBER		CLIP COLOR
	CLOCKWISE (RH)	COUNTERCLOCKWISE (LH)	
4 (Optional)	1707051	1707049	Green
5 (Standard)	1707047	1707045	Tan
6 (Standard)	1707041	1707039	Purple
8 (Standard)	1707018	1707016	Grey
10 (Standard)	1707006	1707004	Blue

TO REMOVE A SPIRAL:

- Pull forward on the retaining clip and remove the end of the spiral from the spiral coupler as shown.
- Remove the spiral from the tray.

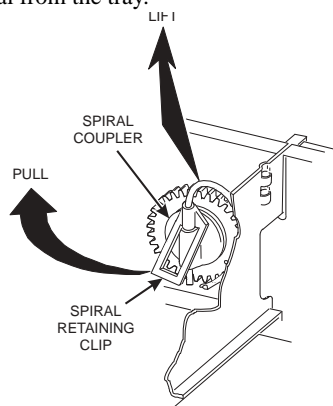

Frozen Gourmet Setup and Operators' Guide

TO INSTALL A SPIRAL:

- c. Pull the bottom of the retaining clip toward the front of the spiral.
- d. Lower the spiral into the tray column and insert the end of the spiral into the spiral coupler as shown.
- e. Release the retaining clip.

SHOULD I USE A CLOCKWISE OR A COUNTERCLOCKWISE SPIRAL?

- f. The type of spiral used is determined by the column position it will occupy in the tray.
- g. Refer to the figure below to find the correct spiral type.

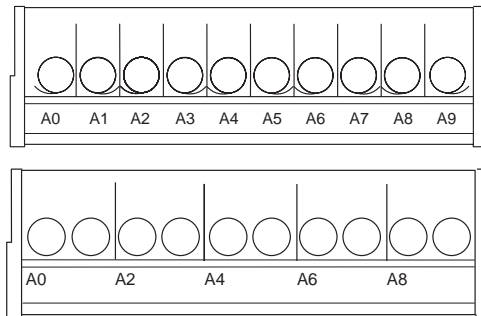

REMOVING A SPIRAL COUPLER:

- h. Pinch together the prongs on the end of the spiral coupler as shown.
- i. Pull the coupler forward (in the direction of the arrow as shown).

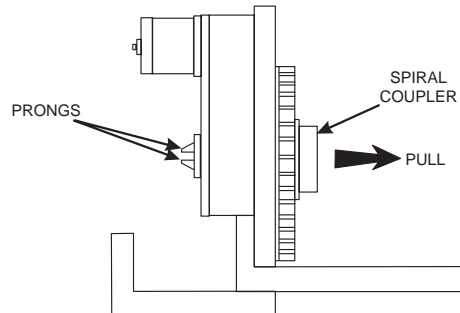

Frozen Gourmet Setup and Operators' Guide

5. Removing and Installing a Spiral Motor:

REMOVING A SPIRAL MOTOR:

NOTE

Some steps may already be completed.

- a. Remove the tray. See **REMOVING A TRAY** (page 8).
- b. Disconnect the motor harness. See **CONNECTING AND DISCONNECTING A MOTOR HARNESS** (page 11).
- c. Remove the spiral. See **REMOVING AND INSTALLING SPIRALS** (page 14).
- d. Remove the spiral coupler. See **REMOVING A SPIRAL COUPLER** (page 15).
- e. Lift the motor clear of the tray.
- f. Return the tray to the merchandiser. See **INSTALLING A TRAY IN THE MERCHANDISER** (page 20).

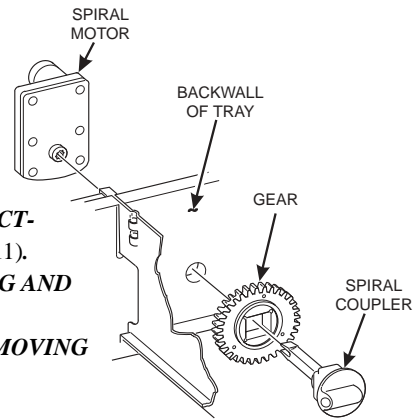

INSTALLING A SPIRAL MOTOR:

- g. Remove the tray. See **REMOVING A TRAY** (page 8).
- h. Place the motor in the correct position at the rear of the tray as shown.
- i. Place a gear in position if required by this set-up. See **INSTALLING A GEAR** (page 17).
- j. Install a spiral coupler in the proper orientation. See **INSTALLING A SPIRAL COUPLER** (page 18).
- k. Connect the motor harness. See **CONNECTING AND DISCONNECTING A MOTOR HARNESS** (page 11).
- l. Return the tray to the merchandiser. See **INSTALLING A TRAY IN THE MERCHANDISER** (page 20).

Frozen Gourmet Setup and Operators' Guide

6. Installing a Gear

WHEN ARE GEARS USED?

- Gears are used to mechanically couple the spirals together.
- This happens whenever you have two spirals and only one motor for vending a selection.

WHERE ARE THE GEARS PLACED?

- The gear is placed between the back of the tray and the spiral coupler.

HOW IS THE GEAR ORIENTED?

- There are two possible orientations for the gear:

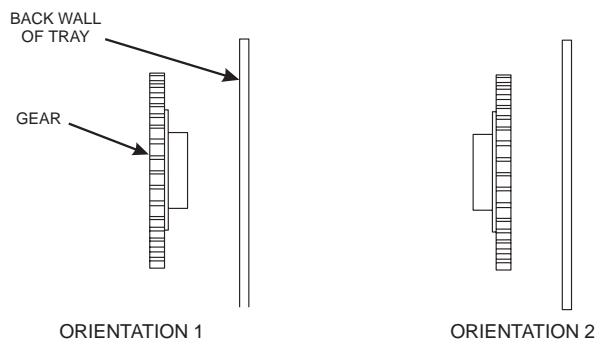

- There are two rules to follow when orienting gears:

RULE 1 - The gears for selections next to each other cannot use the same orientation.

RULE 2 - All gears for a single selection must use the same orientation.

Frozen Gourmet Setup and Operators' Guide

7. Installing a Spiral Coupler

- a. Place the gear in position if one is required for this set-up. See *INSTALLING A GEAR* (page 17).

WHEN USED WITH A MOTOR:

- b. Hold the motor in place and push the spiral coupler through the motor gear box until it clicks into position. Be sure the spiral couplers are oriented as shown below.

NOTE

The motor output shaft opening contains eight facets to allow the spiral coupler to be installed in any one of eight positions.

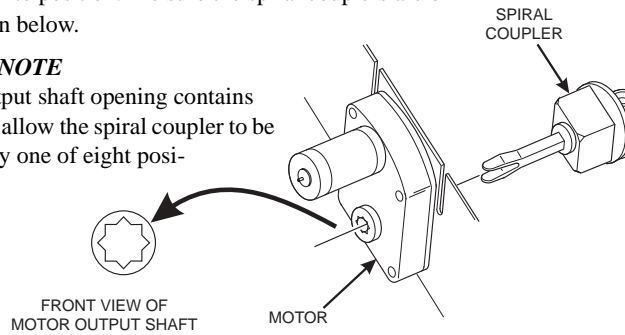

SPIRAL COUPLER ORIENTATION

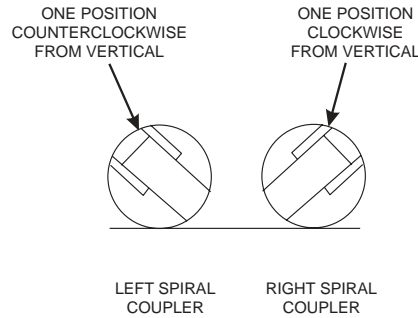

AS VIEWED FROM FRONT OF TRAY

WHEN USED WITH A COUPLER BEARING:

- c. Hold the coupler bearing in place and push the spiral coupler through the bearing until the coupler clicks into position. Be sure the coupler is in the proper orientation as shown.

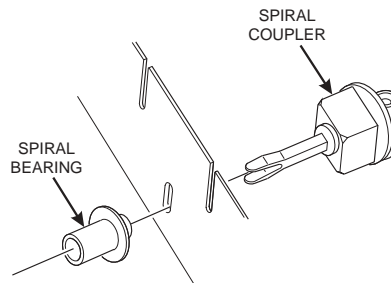

Frozen Gourmet Setup and Operators' Guide

8. Moving a Tray Up or Down

This merchandiser can be adjusted to vend taller products. Some guidelines must be followed:

- Keep in mind that when you increase the product height available to a tray by lowering it, you will be decreasing the product height available to the tray below.
- If a tray is in the lowest position, the tray below it should not be in the highest position.
- If a tray is in the highest position, the tray above it should not be in the lowest position.
- You will need to experiment with various tray positions to get the best results for your products.

NOTE

Trays should not be positioned over an open air discharge vent.

NOTE

Tray movement is limited because the tray harness will limit the amount of travel available to the tray guide rails.

Proceed as follows:

- Remove the tray from the merchandiser. See ***REMOVING A TRAY*** (page 8).
- Remove the screw that secures the right tray guide rail to the front guide mounting channel as shown.
- Tap up on the guide rail and unseat the guide rail tabs from the channel slots.
- Pull the guide rail away from the front and rear guide mounting channels.
- Move the guide rail to the desired position.
- Insert the guide rail tabs into the mounting CV channel slots as shown.
- Tap down on the guide rail to seat the tabs in the channel slots.
- Replace the screw that secures the guide rail to the front guide mounting channel.
- Repeat steps b through h for the left guide rail.
- Return the tray to the merchandiser. See ***INSTALLING A TRAY IN THE MERCHANDISER*** (page 20).
- Load products into the trays, and perform test vends. Make sure the trays don't interfere with the products you are vending, and that all products vend properly.

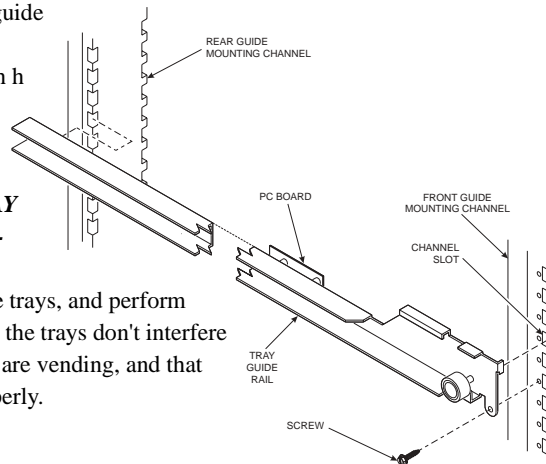

Frozen Gourmet Setup and Operators' Guide

9. Installing a Tray in the Merchandiser

Study this procedure before you install a tray for the first time; while you are holding the tray you will not be able to see this area. Proceed as follows:

- a. Insert the tray so that the tray rollers pass over the tray guide rollers.

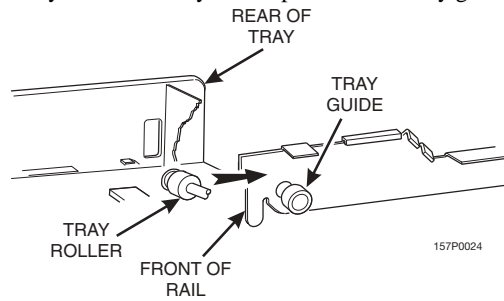

- b. Bring the tray roller to rest on the tray guide.

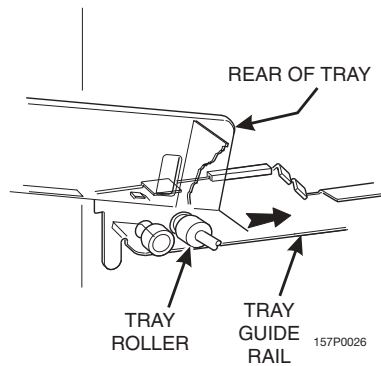

- c. Tilt the tray upward.
- d. Connect the tray wiring harness to the PC board mounted to the guide rail **JUST ABOVE** the tray you are installing.

Frozen Gourmet Setup and Operators' Guide

Load Trays With Product

Spiral Capacities and Color Codes

ITEM CAPACITY OF SPIRAL	PART NUMBER		CLIP COLOR
	CLOCKWISE (RH)	COUNTERCLOCKWISE (LH)	
4 (Optional)	1707051	1707049	Green
5 (Standard)	1707047	1707045	Tan
6 (Standard)	1707041	1707039	Purple
8 (Standard)	1707018	1707016	Grey
10 (Standard)	1707006	1707004	Blue

The color of the spiral coupler (the little plastic tab attached to the rear of the spiral) will tell you how many products will fit in the spiral. See the column at left.

NOTE

Another way to determine spiral capacity is to count the spaces in the spiral!

1. Loading a Tray With Products In General:

- See **PRODUCT PUSHER USAGE** (page 22) for spirals with capacity of 10 products.

SPECIAL CONSIDERATIONS:

- Bagged Products - Position package upright, then push the tops slightly toward the rear of the tray. Also, see **PRODUCT PUSHER USAGE** (page 22).
- Thin Packages - Position the package upright

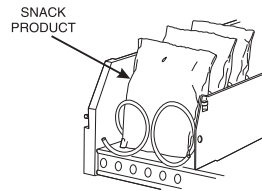

CORRECT LOADING OF SNACKS

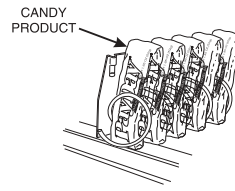

CORRECT LOADING OF CANDY 157P0035

Frozen Gourmet Setup and Operators' Guide

2. Product Pusher Usage:

The product pusher will give the top of a product an extra tilt to help it fall into the delivery pan.

Use a product pusher in the following cases:

- The spiral has a capacity of 15, 13, or 11.
- The package is non-rigid like bagged peanuts

The product pusher can also be used with other spiral and types of products.

A bag of product pushers has been shipped with the merchandiser. Additional product pushers are available from the National Vendors' parts department. To use a product pusher, snap it on the spiral as shown. You can adjust the product pusher by moving it around on the spiral to achieve the best vending results.

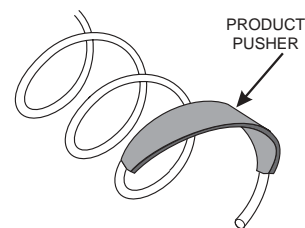
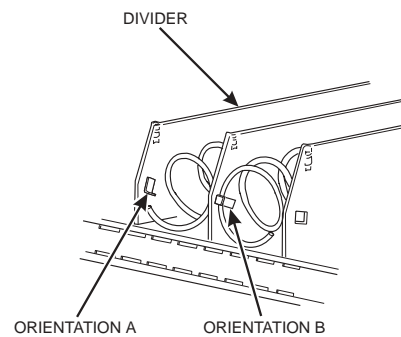

Frozen Gourmet Setup and Operators' Guide

Return the Trays to the Vending Position

- a. Lift the tray until it is parallel to the floor as shown.

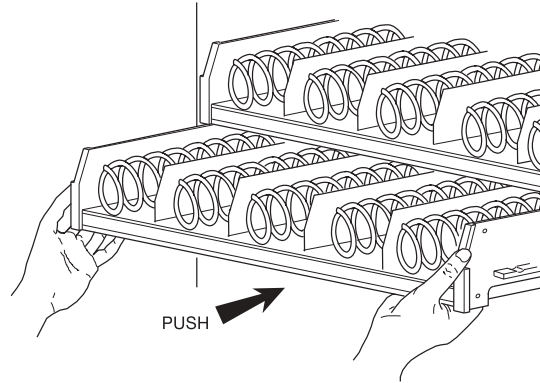

170P0017

- b. Push the tray toward the back of the cabinet. The tray will index into a detented "home" position.

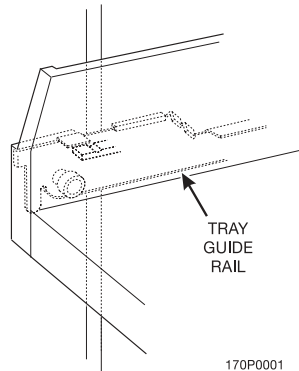

170P0001

Frozen Gourmet Setup and Operators' Guide

Install and Set Price Labels

- Price rolls are printed on coiled-up strips as shown in this example. (The cents rolls are factory installed.) If you use another type of currency, you will find the appropriate price rolls in the plastic bag that contained this manual.

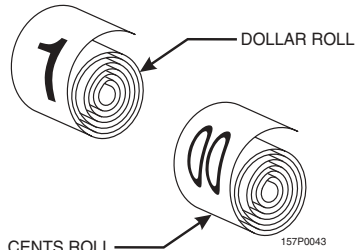

- There are two types of price rolls installed:
 - Dollar roll - 1 to 12, increments of 1
 - Cents roll - 00 to 95, increments of 05

- Remove the price rolls as required, and install the appropriate one(s) for your currency.

1. Installing Price Labels:

- There are three pairs of slots in the front of the tray for each position. Install per this example:
 - Insert the dollar roll in the left-most pair of slots as shown if the price is \$1.00 or more.
 - Insert the cents roll in the center pair of slots as shown.
 - The low-number end of the roll goes in the top slot and the high-number end of the roll goes in the bottom slot.

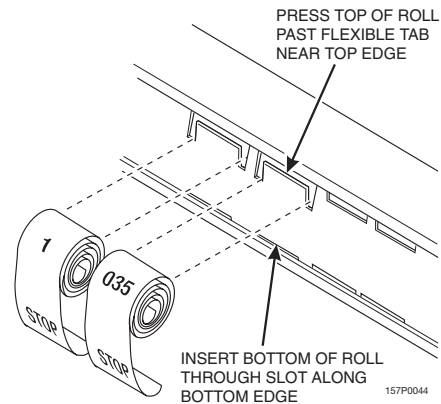

2. Adjusting the price roll:

You can set selection prices within the following range:

Minimum price \$.00
Maximum price \$12.95
Increment \$.05

- Use your thumb as shown to move each price roll up or down as needed to set the desired price.

NOTE

You will see the word STOP near either end of the roll.

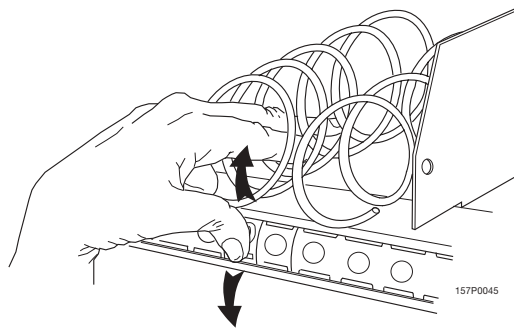

Frozen Gourmet Setup and Operators' Guide

Install Selection ID Labels

Selection ID numbers are printed on clear plastic sheets. You will find these in the plastic bag that contained this manual. You will need to separate them along the scored lines between the selections. **BE CAREFUL** when doing this.

1. Installing Selection ID Numbers:

- a. Press together the two long edges of the selection ID label.
- b. Snap the selection ID label into position on the front of the tray as shown.

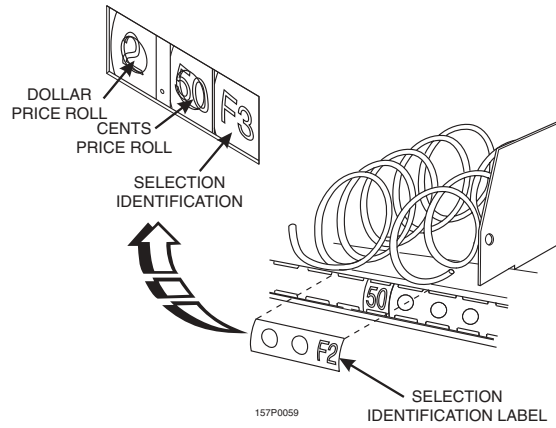

Frozen Gourmet Setup and Operators' Guide

2. Which ID Label Goes With Which Selection?

See the figures below for tray positions.

MOTOR POSITION

TOP TRAY	TRAY A	A0	A1	A2	A3	A4	A5	A6	A7	A8	A9
	TRAY B	B0	B1	B2	B3	B4	B5	B6	B7	B8	B9
BOTTOM TRAY	TRAY C	C0	C1	C2	C3	C4	C5	C6	C7	C8	C9

NOTE

This example shows a 3-tray merchandiser.

EXAMPLE OF A BASIC
WIDE TRAY ID LABEL
TO USE

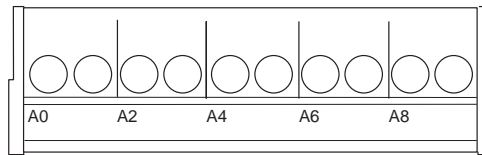

EXAMPLE OF A BASIC
10 SELECT TRAY ID
LABEL TO USE

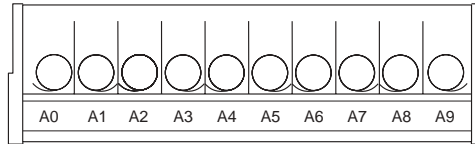

Frozen Gourmet Setup and Operators' Guide

Refrigeration System

1. Screens:

The air inlet screen is located on the floor of the cabinet, and the air discharge screen is located on the rear of the cabinet. They must be kept clean and free of dust and debris.

2. Spacing:

Leave 6" of space between the rear of the cabinet and any surface that may impede the flow of air from the rear screen.



Frozen Gourmet Setup and Operators' Guide

Accessories

1. Install the Lock Cylinder:

Install an optional lock cylinder in the merchandiser as follows:

- a. Position the lift handle lock lever as shown.
- b. Depress the lock spring at the square hole of the lock cylinder receptacle and pull the lock springs out through the front.
- c. Position the lock cylinder as shown. Depress the spring loaded lock pin.
- d. Push the cylinder into the cylinder receptacle in the lever. The pin should snap into the square hole.
- e. If the cylinder pin does not seat in the square hole, press against both ends of the lock cylinder. Rotate the cylinder until the pin snaps into place.
- f. **Leaving the door open**, test the lock mechanism with a key.

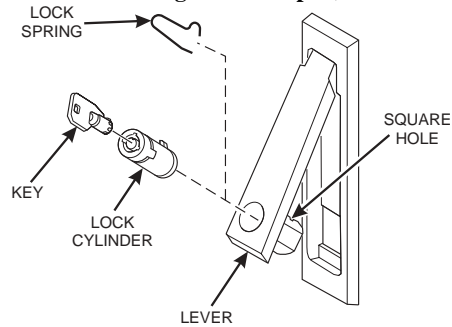

The optional door locks available from Crane Merchandising Systems are listed below:

- Flex-Ace (P/N 9992000)
 - Corresponding key (P/N 9994000)
- Van Lock (P/N 3112163)
 - Corresponding key (P/N 3112164)
 - Kit-lock and key (P/N 3112165)

2. Install the Optional Cash Box Lock:

- a. Remove the cash box from the merchandiser.
- b. Assemble the lock as shown in the illustration below.
- c. Return the cash box to the merchandiser.

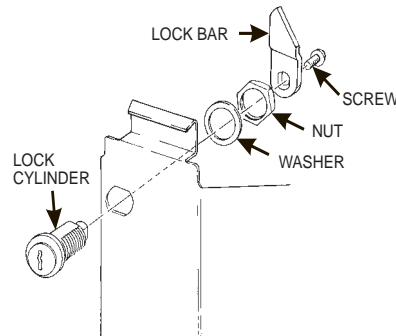

3. Load the Coin Mechanism:

- a. Insert coins one at a time until each of the coin tubes has been filled.
- b. Inspect the tubes for coins that are not stacked squarely and correct if necessary.

Frozen Gourmet Setup and Operators' Guide

Basic Programming

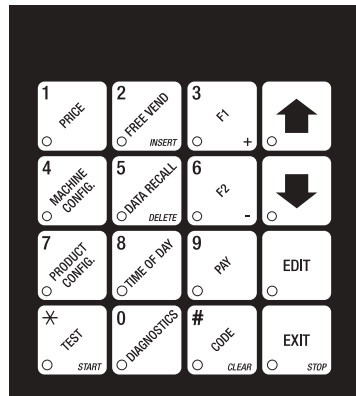



Service Keypad

The service keypad (shown on the left) is your major tool to program your merchandiser. The minimum programming required to get your merchandiser running is setting the prices. That procedure is given below. For a thorough explanation of how to adjust the custom programming features available to you, consult your *Programming Guide*. It will describe how to:



- Set up custom time-of-day vending periods;
- Look at sales and vending data;
- Test various machine functions;
- Customize trays for vending unique products;
- Enter custom display messages;
- **And much more!**

1. Set Prices

- Press . The display shows **** 2.50 .25**. This display shows the maximum and minimum prices set in the machine. In this example, the maximum price is \$2.50 and the minimum is \$0.25.
- Press the number of the selection to be priced. (Example: B1.) The display shows **B1 X.XX**. Enter a price using the number keys. The selection is now priced.
- Press another letter key, or  to price another selection.

Frozen Gourmet Setup and Operators' Guide

2. View the Cabinet Temperature

- a. Press . Depending on how your machine is configured, the display will show, for example, *TEMP -10° F*. This example shows that the temperature is -10 degrees Fahrenheit.
- b. If you need to change the cabinet temperature setting, refer to your *Programming Manual*.
- c. To change the display units, press . The display now shows *TEMP -23° C*.
- d. An **I** replacing the **F** or **C** means a sensor error exists and the displayed temperature is invalid. A decimal point in the display means the compressor is running; an apostrophe means the heater is on.



NOTE

When the machine door is closed, you can view the temperature by

pressing  on the selection panel.

- e. Press  until you have left the function.

3. View the Evaporator Temperature

- a. Press , then . The display will show, for example, *TEMP2 34° F*. This example shows that the temperature is 34 degrees Fahrenheit. This temperature is non-adjustable and is only used at the factory for reference.
An **I** replacing the **F** or **C** means a sensor error exists and the displayed temperature is invalid.
- b. Press  until you have left the function.

4. Freezer Defrost



Freezer defrost is set at 4 cycles per 24-hour period as a factory default setting. If you need to change the number of defrost cycles per 24-hour period, refer to your *PROGRAMMING GUIDE*.

Frozen Gourmet Setup and Operators' Guide

Final Checkout

Now, you have placed your merchandiser in its final location, connected it to the utilities, loaded it with products, and set the prices. Before you lock the door and move on, you should check to see if your merchandiser will vend products. To identify any problems, perform the following operational readiness checks:

1. Test Vend Selections

- a. Press . The display shows *TEST .00*. You may now test vend selections. If you insert money into the machine, the zeros in the display will be replaced with the amount of the credit. After the item vends, your money will be returned.
You may make one more test vend if you close the door while still in TEST VEND mode.
- b. Press  until you have left the function.

2. Operational Readiness Check

- a. Perform test vends on all selections.
- b. Do any of the products catch on the tray and fail to vend? If not, skip to step c. If so, perform the following procedures on the affected areas until all products vend properly:
 1. Install a product pusher.
 2. Perform the appropriate spiral anti-hang-up procedure(s) (see below).
- c. Test the operation of the coin mechanism (see the *Programming Guide* for the proper procedure.).
- d. Test the operation of the bill validator.
- e. Return all test vended products to the trays.

Frozen Gourmet Setup and Operators' Guide

3. Spiral Indexing Procedure (One Spiral, One Motor)

The spiral indexing procedures involve rotating spirals one position at a time until the product vends properly.

- a. Home all the motors (see the *Programming Guide*).
- b. Remove the affected spiral.
- c. Is the coupler in the proper position?
NO - Move the coupler to the position as shown in *INSTALLING A SPIRAL COUPLER* (page 18). Go to step d.
YES - Move the coupler to the next clockwise position (if it's on a right-hand motor), or the next counterclockwise position (if it's on a left-hand motor). Go to step d.
- d. Replace the spiral.
- e. Perform a test vend (see page 31).
- f. Did the product hang up?
NO - You're finished. Continue to test vend the remaining selections until everything works right.
YES - Go to step g.
- g. Did you previously move the coupler to the next clockwise or counterclockwise position?
NO - Move the coupler to the next clockwise position (if it's on a right-hand motor), or the next counterclockwise position (if it's on a left-hand motor). Return to step 6.
YES - Return to step b in the operational readiness check (see page 31) and try another procedure. Do not move the coupler again.

Frozen Gourmet Setup and Operators' Guide

4. Spiral Indexing Procedure (Two Spirals, One Or Two Motors)

The spiral indexing procedures involve rotating spirals one position at a time until the product vends properly.

- a. Home all the motors (see the *Programming Guide*).
- b. Remove the left hand spiral of the affected pair.
- c. Is the coupler in the proper position?
NO - Move the coupler to the position as shown in *INSTALLING A SPIRAL COUPLER* (page 18). Go to step d.
YES - Move the left coupler to the next counterclockwise position. Go to step d.
- d. Replace the left hand spiral.
- e. Remove the right hand spiral, spiral coupler, and gear (if used) of the affected pair as a unit.
- f. Rotate this unit until the right hand spiral mirrors the position of the left hand spiral.
- g. Replace the right hand spiral, spiral coupler, and gear (if used).
- h. Perform a test vend (see page 31).
- i. Did the product hang up?
NO - You're finished. Continue to test vend the remaining selections until everything works right.
YES - Go to step j.
- j. Did you previously move the left hand coupler to the next counterclockwise position?
NO - Remove the left hand spiral of the affected pair. Turn the left spiral coupler to the next counterclockwise position. Return to step 4.
YES - Return to step b in the operational readiness check (see page 31) and try another procedure. Do not move the coupler again.

5. Testing the Bill Validator

- a. Insert a \$1 bill into the validator.
- b. Push the coin return button.
THE BILL VALIDATOR IS IN THE ESCROW MODE - No money is returned - you must make a selection in order to receive any change. Go to step c.
THE BILL VALIDATOR IS NOT IN THE ESCROW MODE - You should receive four quarters in change. Go to step c.
- c. Make a selection. the correct selection should be vended and correct change should be returned.

Frozen Gourmet Setup and Operators' Guide

Routine Service and Sanitation

Sanitation is an important phase of merchandiser operation. The lack of proper cleaning and sanitation can cause merchandiser malfunction and loss of sales.

The periods and suggested procedures for cleaning and sanitation are given as guides only, and are not to be construed as absolute or invariable. Local conditions must always be taken into consideration. Certain installations require that some or all of the steps under Monthly Service and Monthly Sanitation be performed weekly. Each merchandiser must be maintained individually in accordance with its particular requirements. We, however, stress "**A CLEAN MERCHANDISER IS THE MOST PROFITABLE MERCHANDISER**".

Cleaning means "free of visible soil".

Sanitizing means effective bactericidal treatment of clean surfaces of equipment and utensils by a process which has been approved by the health authority as being effective in destroying microorganisms, including pathogens. *When you sanitize you create a healthy and hygienic condition.*

Sanitizing processes generally accepted by the health authority are as follows:

1. **Heat:** Immersion of the object for at least 30 seconds in clean hot water of at least 170°F (24°C). Hot water at 170°F (77°C) and above can cause burns to the skin. Exercise caution when working with hot water at this temperature.
2. **Chemical:** Treat the object to be sanitized with a bactericidal compound. Follow the instructions on the bactericide's label. A chlorine sanitizer can be made by adding one teaspoon of household chlorine bleach to one gallon of water having a temperature of no lower than 75°F (24°C). Air dry do not wipe dry. The following cautions are applicable to the service and sanitation procedures given in this section:

CAUTION

Follow local health authorities' rules and regulations for storage and handling of perishable products.

IMPORTANT

All loose food particles or spillage, whether wet or dry, must be removed from the inside and outside of the merchandiser.

CAUTION

Do not get electrical connections or electrical components damp or wet.

NOTICE

Do not use waxes or lubricants which contain silicone on or in the merchandiser. Silicone or silicone vapors can cause electrical failure.

Frozen Gourmet Setup and Operators' Guide

GENERAL

Set the main power switch OFF before cleaning or servicing the merchandiser. Use aerosol spray cleaners or spray waxes only in well-ventilated areas. NEVER use any spray product containing silicone. Silicone sprays can coat electrical contacts, causing a machine malfunction.

WARNING

Before using any liquid cleaner, unplug the merchandiser power cord or shut off power to the wall receptacle to avoid any possibility of electrical shock. Make certain all components are thoroughly dry and properly installed before restoring power.

Refer to the Parts Manual for additional service information and replacement parts. For factory assistance, contact the nearest National Vendors representative.

Contact the local health authorities and obtain their acceptance of the sanitizer you intend to use when cleaning and sanitizing the merchandiser.

When cleaning and sanitizing the merchandiser, use CLEAN, DISPOSABLE PAPER WIPES rather than cloths.

DAILY SERVICE

- a. Replace burned-out or discolored light bulbs.
- b. Replenish coin tubes in the coin mechanism.
- c. Empty the bill validator as shown.
- d. Test vend the merchandiser. See **TEST VEND SELECTIONS AND VERIFY CREDIT ADDED**, *Programming Guide*, page 40.
- e. Check the temperature of the cabinet. See **VIEW CABINET TEMPERATURE**, *Programming Guide*, page 28.
- f. Follow the daily sanitation procedures, then reload the merchandiser.

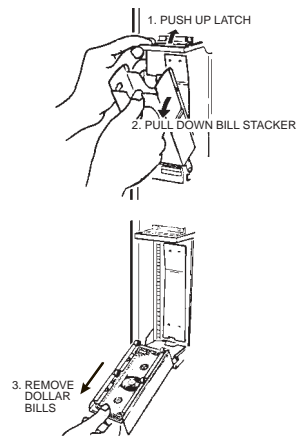

Emptying the Bill Validator

Frozen Gourmet Setup and Operators' Guide

DAILY SANITATION

- a. Remove all past-date merchandise from the merchandiser.
- b. Check for liquid spillage on the merchandiser trays. If there is spillage, remove the trays and dividers affected. Wash and sanitize the trays and dividers with a clean, damp disposable paper wiper or a clean soft-bristle brush. Rinse with clean hot water and dry thoroughly.
- c. Wipe the exterior of the merchandiser with a damp disposable paper wiper and dry thoroughly.
- d. Fill in the appropriate columns on the record of cleaning card.

MONTHLY SERVICE

- a. Follow the daily service instructions.
- b. Inspect the refrigeration screen. Remove any accumulated dust.

WARNING

Be sure the area is well ventilated and no open flames are present before using any aerosol spray can.

WARNING

Use protective glasses or a protective shield if an air hose is used for drying.

- c. Clean the coin chute and coin validator. (See **CLEANING THE COIN VALIDATOR AND COIN CHUTE**, page 36.)
- d. Clean the bill validator. (See **CLEANING THE BILL VALIDATOR**, page 36.)

MONTHLY SANITATION

- a. Follow the daily sanitation instructions.
- b. Inspect the merchandiser for overall cleanliness, especially the corners.
- c. Wash and sanitize the merchandiser food compartment with a clean, damp disposable paper wiper. Dry thoroughly.
- d. Fill in the appropriate columns on the record of cleaning card.

CLEANING THE COIN VALIDATOR AND COIN CHUTE

Inspect the coin validator and coin chute at regular intervals. Clean them on approximately a monthly schedule.

- a. Remove the coin validator assembly from the merchandiser.
- b. Clean the coin chute with a tube cleaning brush to remove any accumulated dust and foreign matter.
- c. Refer to the coin validator instruction booklet and follow the recommended cleaning procedure.

CLEANING THE BILL VALIDATOR

- a. Refer to the bill validator instruction booklet and follow the recommended cleaning procedure.

This Merchandiser is warranted for one (1) year against defective parts and workmanship. Any part or parts which are proven to be defective within one (1) year of the date of shipment will be repaired or replaced free of charge when the defective part is returned, with transportation charges prepaid, to the destination designated by the National Vendors Warranty Department.

The refrigeration system is warranted for (2) years against defective parts and workmanship. Any part or parts of the refrigeration system which are proven to be defective within (2) years of the date of shipment of the merchandiser will be repaired or replaced free of charge when the defective part(s) is returned, with transportation charges prepaid, to the destination designated by the Crane Merchandising Systems Warranty Department.

This warranty applies only to the original purchaser of the Merchandiser and is null and void if the Merchandiser is sold during the period of warranty.

This warranty does not apply to a) electrical components, wiring, or circuits and/or for all mechanical parts or assemblies damaged as a result of operating the Merchandiser at other than the design voltage and frequency specified on the Electrical Rating Tag, or b) in event of vandalism, fire or negligence, or c) incandescent lamps, neon lamps, fluorescent lamps, ballasts, starters or other expendable items or d) when other manufactured components are installed in National Vendors Merchandisers.

National Vendors is not responsible for any cost of service rendered or repairs made by customer or its agents on Merchandiser or parts unless authorization to incur such expense has been given in writing by National Vendors prior to incurring such expense.

THIS WARRANTY IS IN LIEU OF ALL OTHER WARRANTIES EXPRESSED OR IMPLIED, INCLUDING WITHOUT LIMITATION, WARRANTIES OF MERCHANTABILITY OR FITNESS FOR A PARTICULAR PURPOSE. NATIONAL VENDORS SHALL NOT BE RESPONSIBLE FOR CONSEQUENTIAL OR PUNITIVE DAMAGES. National Vendors neither assumes nor authorizes any person to assume for it any obligation or liability in connection with the sale of said equipment or any part thereof.

Crane Merchandising Systems

A Division of CRANE CO
12955 Enterprise Way
Bridgeton, MO 63044

