



Royal Vendors • 201 Industrial Boulevard • Kearneysville, W.V. 25430
Customer Service: (304) 728-7056 or Toll Free (800) 931-9214 • Fax (304) 725-6579

Email: Technicalinquiry@royalvendors.com
Parts@royalvendors.com

Web page: www.royalvendors.com

TABLE OF CONTENTS

1. General Information	4
Introduction to “Merlin IV”	4
“Merlin IV” Features	4
Vender Identification	5
Credit and Replacement Policy	6
2. Vender Component Explanation	7
Vender Control Board (Including Pinouts)	7
Low Voltage Transformer	12
Delivery Chute Sensor (Including Adjustment)	13
Refrigeration System	14
3. Vender Programming.....	17
The Necessity Of Correct Programming	17
Precautions To Take When Working With The Control Board	17
Introduction To Programming	17
Menu Levels	18
INTERNAL (Service) MENU	19
CASH (cash counter) Mode	19
SALE (sale counter) Mode	19
Error (errors) Mode	19
tESt (column test vend) Mode	20
PriC(selection price) Mode	20
StoS (space to sales) Mode	21
SdEP (set vending depth) Mode	21
Con (configurations) Mode	22
rtn (return to sales) Mode	23
OPTIONAL MENU (If Con 2 is set “1”)	23
ECO (exact change mode)	23
CPO (coin payout) Mode	23
tUFL (coin tube fill) Mode	23
dSAL (discounted sale counter) Mode	24
diFc (discounted differential cash counter) Mode	24
SdiS (discounted selection price) Mode	24
StCL (set timer controlled selections) Mode	25
tinE (time and timer settings) Mode	25
FriG (refrigeration parameters) Mode	28
PAS (External Menu password setting) Mode	29
LAnG (international language setting) Mode	30
rtn (return to sales) Mode	30
External Menu (accessible while in the “greeting” mode)	30
SALE (sale counter) Mode	30
rtn (return to sales) Mode	31
Error (errors) Mode	31
4. Vend Cycle	32
Stand by Condition	32
Establishing Credit	32
Valid Selection	32
Vend Sequence	32

TABLE OF CONTENTS CONTINUED

Product Delivery	32
Sold Out	32
Resetting Sold Out Selections	32
5. Vender Maintenance	33
General Maintenance	33
Using The Vender's Error Code System	34
Error Codes	34
Troubleshooting	35
Coin Acceptance	35
Bill Acceptance	36
Vending Problems	37
Miscellaneous Problems	38
Refrigeration Problems	39
Refrigeration Flow Chart	41
6. Exploded Views and Part Numbers	42
Control Board and Wiring	42
Port Assembly	44
Inner Door Assembly	46
Main Door Hinge, T-Handle And Door Lifter Assemblies	48
Refrigeration System Assembly	50
Evaporator Fan Motor Assembly	52
Vend Mechanism Assembly	54
Miscellaneous Assemblies	56
Door Assembly, Front	58
Door Assembly, Rear	60
Select Panel Assembly, Rear	62
RVMC/RVCD Vandal Resistant Door (CDC) Front	64
RVMC/RVCD Vandal Resistant Door (CDC) Rear	66
RVMC/RVCD Center Door Changer Vault	68
Port Assembly, Dr Pepper Vision 4	70
Door Assembly Front, Dr Pepper Vision 4	72
Door Assembly Rear, Dr Pepper Vision 4	74
Coin Insert Assembly Front, Dr Pepper Vision 4	76
CI Rear and Button Panel Assembly, Dr Pepper Vision 4	78
Changer Vault Assembly, Dr Pepper Vision 4	80
Flat Horizontal Display, Door Front	82
Flat Horizontal Display, Door Rear	84
Flat Horizontal Display, Select Panel	86
Programming Flowchart	88

SECTION 1: GENERAL INFORMATION

General Information

INTRODUCTION TO “MERLIN IV”

The MERLIN IV can and bottle vender is capable of vending most packages. It uses a Control Board to manage vending operations. This Control Board must be programmed correctly for the Vender to operate properly. Through the Vender’s electronic Control Board, you will find better space to sales allocations which will increase profits through fewer sold out selections and less loading frequency.

Through MERLIN IV’s flexibility, you will profit by using the Multi-Pricing and Space to Sales features. As you will see later in the Manual, there are other features, such as the ability to control vending by using a “built in” timer or by using an optional on/off key switch. Like most electronic equipment, the Control Board has the ability to control most items in the vending machine. It manages the operation of the Refrigeration System and even the lighting system, with an optional kit. MERLIN IV utilizes high torque 24 volt DC vend motors. Testing has proven these vend motors to be very strong and reliable.

MERLIN IV’s programming is done “Menu Style” with the menus consisting of “Main Items” and “Sub-Items”. Figure 1.1 is a good example of how the menu system works.

“Cash” is the first menu after pressing the mode button on the control board. You can only access menu items from the menu you are in. Just as the “ENTER” button takes you into each level, the “HOME” button takes you back to previous menu levels each time you press it. The menu system is explained in greater detail in Section 4, Vender Programming: Menu Levels.

Merlin IV

MERLIN IV FEATURES

- Field proven, reliable impact delivery sensor detects the vend to cancel vend cycle.
- Patented learning mode for quick vending.
- A “Direct drive” DC vend motor in each column drives each column’s vend rotor.
- No vend mechanism adjustments are necessary to change from 12oz. cans to 16oz. or 20oz. bottles. All that is needed is to change the depth setting in the programming and product retainers / rear spacers adjustments.
- User friendly menu style programming
- Hand Held Computer (HHC) programming and data retrieval.
- Real time clock / calendar to control “built-in” timer (can display time on LED).
- MERLIN IV supports Multi-Drop Bus Coin Mechanisms, bill validators and card readers.
- Allows programmable space to sales: Custom or Factory settings.
- Capable of setting full escrow to vend (even if a column jams).
- External menu allows access to sales (vend) counts and error information.

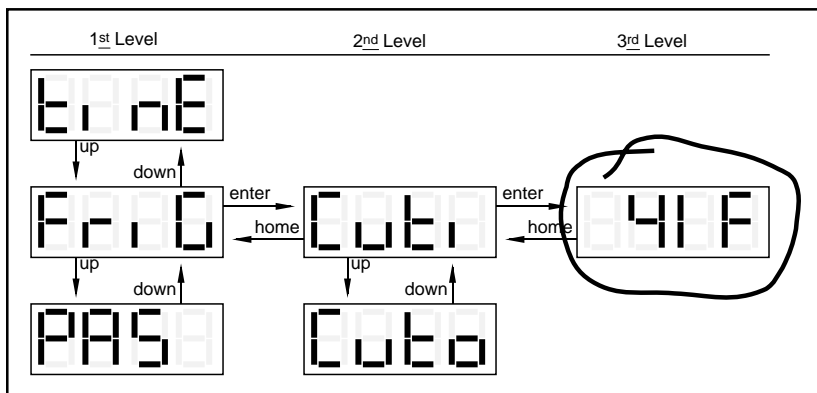

Figure 1.1

SECTION 1: GENERAL INFORMATION

- Both total (historical) and individual (resettable) vend and cash counters.
- MERLIN IV can display the sale (vend) and cash totals (historical) on the LED upon opening the Vender's main door for easy access.

VENDER IDENTIFICATION

Your MERLIN IV vending machine can be easily identified by taking note of the following three items:

1. Vender Serial Plate - mounted on the exterior left side of the Vender door,
2. Refrigeration Serial Plate - mounted on the "kick plate" of the refrigeration unit, and
3. Control Chip Revision Number - mounted on the right side of the Control Board.

VENDER SERIAL PLATE

Note: There are two types of serial plates issued, see figure 1.2 and 1.3.

VENDER SERIAL PLATE - The vender's main serial plate (shown in figures 1.2 and 1.3) is located on the exterior left side of the vender's main door and has the following information:

- Vender model number
- Vender serial number
- Amps required by vender
- Unit charge of R134A
- Refrigeration design pressures

The vender's model number contains two important pieces of information. The machine type such as RVCDE (Royal Vendors Cold Drink Electronic). It also contains the vender model number such as 650-10 (capacity of 650 twelve ounce cans / 10 selections).

How to read a serial number (fig 1.2):

- The first 4 numbers represent the year the vender was produced
- The 5th and 6th numbers represent the week within the year the vender was produced
- The 1st letter represents the style of vender
- The 2nd letter represents the location the vender was built
- The last five numbers represent the model built with in that week

REFRIGERATION SERIAL PLATE

The Refrigeration Serial Plate is located at the bottom of the Vender's cabinet in front of the Condenser coil. It is mounted to the refrigeration unit kick plate. It looks similar to the Serial Plate shown in Figure 1.2 with the exception that the model number specified is the refrigeration unit model (as shown below). There is currently one model in use:

Model	Compressor Size	Usage
8000W	Super 1/3 Horsepower	All MERLIN IV Venders

CONTROL CHIP VERSION NUMBER

The Control Chip Version Number is printed on a white decal located to the top right of the main chip of the Control Board. This number is extremely important when calling for service/programming help, or for matching a replacement Control Board. See fig. 2.2

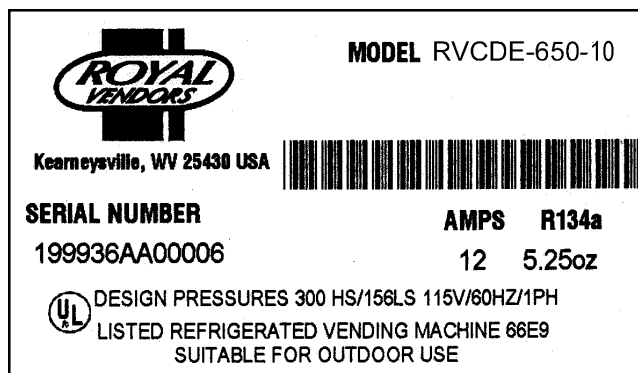

Figure 1.2

IMPORTANT NOTE: To serve you better, we ask you have the following items available before contacting your Royal Vendors' service representative:

- A. Your company's name
- B. Your company's phone number (area code first)
- C. Your first and last name
- D. The Vender(s) model number
- E. The Vender(s) serial number
- F. The Vender(s) Control Board revision number (if concerning a board or programming)

It is also very important to have all of the information about your problem available when you call.

SECTION 1: GENERAL INFORMATION

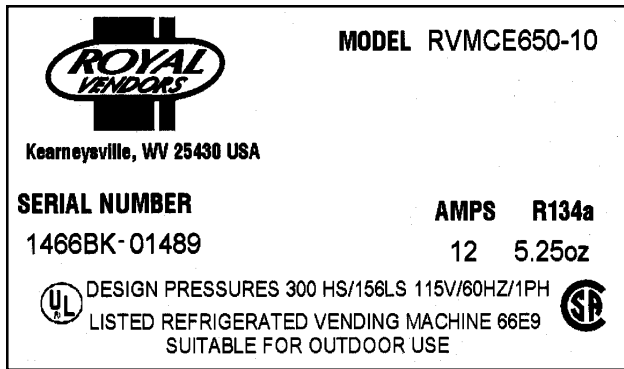

Figure 1.3

How to read a serial number (fig. 1.3):

The vender's model number contains two important pieces of information. The machine type such as RVCDE (Royal Vendors Cold Drink Electronic). It also contains the vendor model number such as 650-10 (capacity of 650 twelve ounce cans / 10 selections).

The vender's serial number contains three important pieces of information. It contains the "Production Run" number such as 1466. The serial number also contains the vender number (from within the "run") such as 01489. Lastly, the serial number contains a date code such as BK. The first initial (B) represents the quarter of the year that the vender was produced:

A = Jan., Feb., Mar. **B = Apr., May, Jun.**
C = Jul., Aug., Sept. D = Oct., Nov., Dec.

The second initial (K) represents the year that the vender was produced:

A = 1988 B = 1989 C = 1990 D = 1991 E = 1992
F = 1993 G = 1994 H = 1995 I = 1996 J = 1997 K = 1998
L = 1999 M = 2000 N = **2001**

CREDIT AND REPLACEMENT POLICY

CREDITS OR REPLACEMENTS WILL BE ISSUED ON WARRANTY ITEMS IF THE PROPER PROCEDURES ARE FOLLOWED:

1. Royal Vendors will pay shipping charges on all parts covered under this warranty, when transportation has been made the most economical way (within the continental US regular ground UPS). An ARS (Authorized Return Service) sticker will be sent with all warranty parts. This method of shipping is preferred for returning parts to Royal Vendors.
2. Credits will only be issued to warranty parts that have been ordered in advance; not for parts ordered as stock (NO EXCEPTIONS).
3. When ordering warranty parts in advance, please have the full Vender / Unit Serial Number.
4. A copy of the Packing Slip, correct Serial Number, and complete Return Material Tag (provided with

part) are required for sending back parts. Please complete the Return Material Tag, keeping the white copy for your records and sending the yellow tag back with the attached part. Make sure you have your company's name, address, phone number, serial number, and model number along with a brief explanation of the problem.

5. If the item returned is not under warranty, it will be sent back to you at your expense or it will be scrapped.
6. All warranty parts should be properly wrapped and packed securely to avoid further damage. Refrigeration units that are returned from the field and have been tapped into, tampered with, not packaged properly, or have had the serial plate removed, will void the warranty.
7. If parts are not returned within 15 working days, the invoice will be due in full.

VOLTAGE REQUIREMENTS

The Vender is designed to operate at a voltage of 115 volts, 60 hertz. It requires a minimum of 15 amp service. The service outlet voltage must not exceed 129 VAC or fall below 103 VAC. The Vender has a three prong, three wire, grounding cord. The Vender must be plugged into a grounded electrical outlet to protect the customer from an electrical shock. If you are not sure your outlet is properly grounded, have it checked by a qualified electrician.

When you plug in the Vender, you should observe the following:

1. The florescent lights displaying the Vender sign will come on.
2. The refrigeration compressor will start to run after approximately 5-7 minutes (*with the door closed*).
3. The LED display will light.

VENDER POWER CORD NOTE

Extension cords are not recommended, unless they are authorized before use by a certified electrician.

SECTION 2. VENDER COMPONENT EXPLANATION

Vender Component Explanation

VENDER CONTROL BOARD (Including Pinouts)

Your MERLIN IV Vender is equipped with a Main Control Board which is responsible for most Vender operations. In most Venders (non-CDC), it is located in the upper section of the Select Panel inside the Vender's main door. The Control Board is protected by a cover. Removing this cover will expose the Control Board in its entirety, along with all of the Control Board's wiring connections.

IDENTIFICATION: The MERLIN IV Control Board can easily be identified by noting the identification number printed on a small white decal on the Control Board's e-prom chip. The Control Board's identification number is a necessity when ordering parts for your Vender and when contacting a Royal Vendors' service representative. The Control Board identification decal is shown in "Vender Identification" of Section 1.

OPERATION REQUIREMENTS: The Control Board requires approximately 24 volts AC from the low voltage transformer (described later in this Section). This will allow the Control Board to function and to supply power to all the Vender's components listed below.

OPERATION: Upon receiving the appropriate voltage from the transformer, the Control Board will issue information to some components, receive information from some components, and communicate both ways with some components.

- The Control Board issues instructions (and/or voltage) to:
 - LED Display
 - Vend Motor (only when vend motor is to run)
 - Refrigeration Relay (for use with Electronic Refrigeration Control)
- The Control Board receives information (and or voltage) from:
 - Select Switches (logic level)
 - Door Switch (logic level)
 - Delivery Chute Sensor
 - Temperature Sensor (for use with Electronic Refrigeration Control)

- The Control Board communicates both ways with:
 - Coin Mechanism
 - Bill Validator (optional)
 - Debit Card Reader (optional)
 - Hand Held Computer (optional)

CONTROL BOARD PINOUTS: The MERLIN IV Control Board has several electrical pinouts, a set-up mode button, a delivery sensor adjustment trimpot, a delivery sensor adjustment indicator lamp, and various other electronic components (all of which have designated position codes). The following section outlines all the Control Board's pinouts by showing for each:

- The pinout position code as found on the Control Board (Example: P15),
- The name/purpose of the pinout (Example: 24 volt power connection),
- A paragraph describing in detail the pinouts purpose and its function, and
- A table describing the pin number, wire number, and function of each position

The word *key* refers to the small plastic insert plugged into a position of the connector. The purpose of the key is to prevent connecting the harnessing backwards or upside-down. The "keyed position" is a blank position within the pinout (no pin) in which a key is inserted. Some pinouts may have several blank positions with a key plugged into one or more of the positions. You can use the key to determine which end of the pinout is Pin 1.

SECTION 2. VENDER COMPONENT EXPLANATION

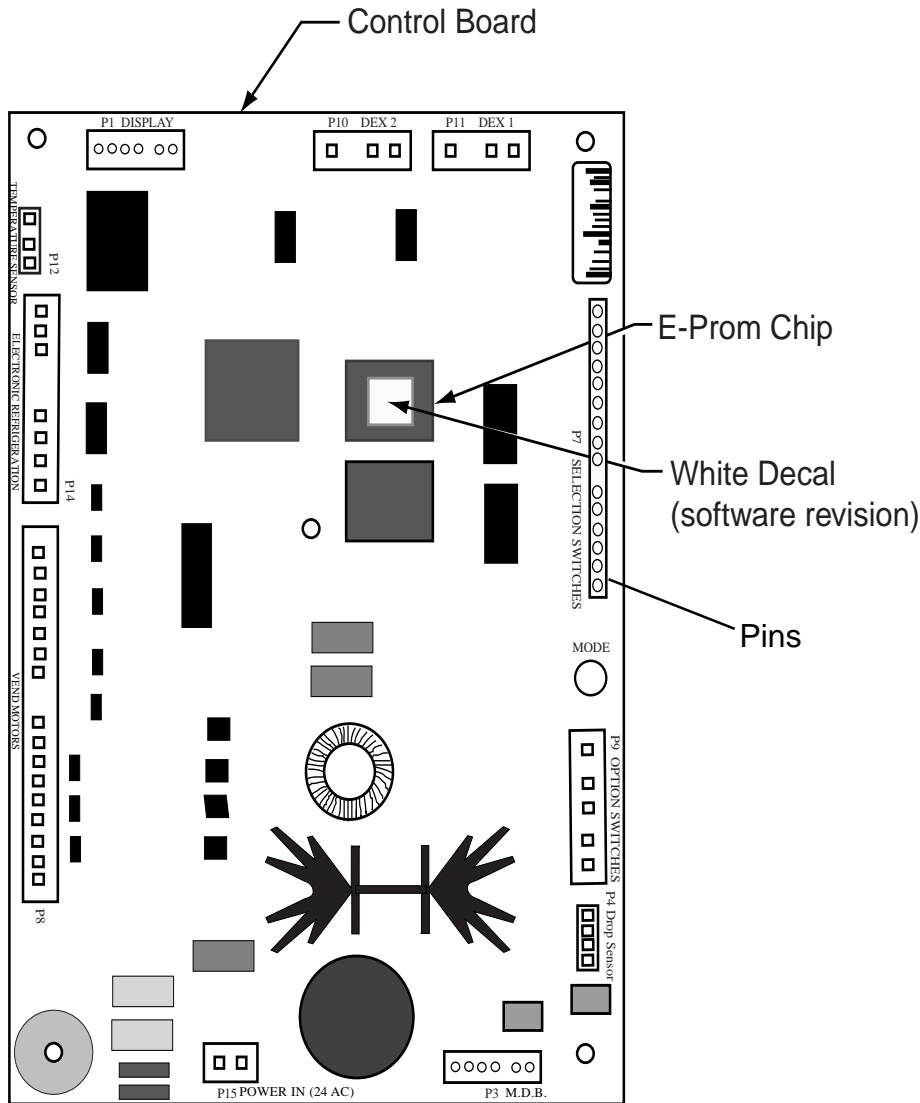

Figure 2.2

MERLIN IV CONTROL BOARD

Standard LED Display Interface (**Position P1**): The four (4) wire harnesses connecting to this pinout travel from the Vender's LED to the Control Board. It allows the Control Board to send power to and communicate with the LED. If this harness is cut or disconnected, the LED will go blank. If this harness is pinched, you may see "broken segments" on the LED with various segments of the display lit.

PIN NUMBER	WIRE COLOR	FUNCTION
1	YELLOW	DISPLAY 5 VOLT DC POWER
2	GREEN	DISPLAY CLOCK
3	BROWN	DISPLAY DATA
4	RED	DISPLAY 5 VOLT DC RETURN TO COMMON

SECTION 2. VENDER COMPONENT EXPLANATION

Multi-Drop Bus (**Position P3**): The five (5) wire serial harness connecting to this pinout provides power and communications to and from the Control Board for the Coin Mechanism, the optional 24 volt Bill Validator, and/or the optional Debit Card Reader. If this harness is cut, pinched, or disconnected, you will noticeably lose power to the Coin Mechanism.

PIN NUMBER	WIRE COLOR	FUNCTION
1	WHITE	MDB 35 VOLTS DC UNREGULATED
2	BROWN	MDB 35 VOLTS DC RETURN TO COMMON
3	KEY	KEY
4	BLACK	VMC RECEIVE/ MDB TRANSMIT
5	RED	VMC TRANSMIT/ MDB RECEIVE
6	GREEN	VMC/MDB COMMON
7	BLUE	NOT USED

Delivery Sensor (**Position P4**): The two (2) wire harness connecting to this pinout is a gray, shielded cable harness. It should never be cut, pinched, or spliced. This harness is formed into the impact sensor (mounted beneath the center of the delivery chute). It travels through the bottom of the Vender's main door to the Control Board.

PIN NUMBER	WIRE COLOR	FUNCTION
1	-	VMC COMMON (2.5DC) RETURN TO GROUND
2	RED	DROP SENSOR OUTPUT #1
3	BLACK	DROP SENSOR OUTPUT #2
4	-	VMC COMMON RETURN TO GROUND

Selection Switches (**Position P7**): The wiring harness connecting to this pinout carries a logic level (ground) signal from Pin #11 of the Control Board to the common position of each Select Switch. Upon activation, the Select Switch will allow the logic level signal to travel back to the Control Board. This will tell the Control Board a particular switch is activated.

PIN NUMBER	WIRE COLOR	FUNCTION
1	WHITE	SELECTION SWITCH #9
2	YELLOW	SELECTION SWITCH #8
3	ORANGE	SELECTION SWITCH #7
4	GREEN	SELECTION SWITCH #6
5	BLUE	SELECTION SWITCH #5
6	BROWN	SELECTION SWITCH #4
7	PURPLE	SELECTION SWITCH #3
8	GREY	SELECTION SWITCH #2
9	BLACK	SELECTION SWITCH #1
10	KEY	KEY
11	RED	SELECTION SWITCH COMMON
12	-	SELECTION SWITCH #12
13	-	SELECTION SWITCH #11
14	PINK	SELECTION SWITCH #10

SECTION 2. VENDER COMPONENT EXPLANATION

Vend Motors (**Position P8**): The fourteen (14) wire harness connecting to this pinout provides common power from the Control Board to each vend motor. There is one wire in this harness for each vend motor to provide each motor with 24 volts DC, when a selection is made. Be sure that this harness is properly grounded.

PIN NUMBER	WIRE COLOR	FUNCTION
15	GREEN/YELLOW	GROUND
14	BLACK	VEND MOTOR COMMON (Source)
13	BLUE/WHITE	VEND MOTOR #12
12	BROWN/WHITE	VEND MOTOR #11
11	ORANGE/WHITE	VEND MOTOR #10
10	KEY	PP
9	YELLOW/WHITE	VEND MOTOR #9
8	RED/WHITE	VEND MOTOR #8
7	GREEN/WHITE	VEND MOTOR #7
6	BLUE	VEND MOTOR #6
5	BROWN	VEND MOTOR #5
4	ORANGE	VEND MOTOR #4
3	YELLOW	VEND MOTOR #3
2	RED	VEND MOTOR #2
1	GREEN	VEND MOTOR #1

Features Connection (**Position P9**): The wiring harness connecting to this pinout travels from the Vender's door switch through the bottom of the Vender's main door and to the Control Board. Pinout P9 is also used for the optional "free vend" and "no vend" key switch kits.

PIN NUMBER	WIRE COLOR	FUNCTION
1	WHITE	FEATURE PLUG/SWITCH COMMON
2	-	KEY
3	(OPTIONAL)	FREE VEND SWITCH INPUT
4	(OPTIONAL)	NO VEND (VEND DISABLE) INPUT
5	(OPTIONAL)	OPTION SWITCH INPUT
6	PURPLE	DOOR SWITCH INPUT

DEX UCS Connection (**Position P10**): The three (3) wire harness connecting to this pinout comes from the Hand Held Computer jack, located inside the Vender's main door (near the Control Board). The Hand Held Computer (HHC) plugs into this jack to read and write information from the Vender's Control Board. If the HHC is not operating properly, check this harness for bad connections at the solder joints. Also check to ensure the insulator is not cracked from over tightening.

PIN NUMBER	WIRE COLOR	FUNCTION
1	RED	VMC TRANSMIT/DEX RECEIVE DATA (TIP)
2	-	KEY
3	WHITE	VMC RECEIVE/DEX TRANSMIT DATA (RING)
4	GREEN	DEX COMMON

DEX UCS Connection (**Position P11**): The three (3) wire harness connecting to this pinout comes from the external Hand Held Computer jack located on top of the welded port assembly. The Hand Held Computer plugs directly into this jack while the Vender's main door is closed to read information from the Vender's Control Board. Information cannot be written to the Vender's Control Board unless the Vender's door switch is in the "door open" position. If the HHC does not operate properly, check the harness for bad connections at the solder joints. Also check to ensure the insulator at the jack is not cracked from over tightening.

PIN NUMBER	WIRE COLOR	FUNCTION
1	RED	VMC TRANSMIT/DEX RECEIVE DATA (TIP)
2	-	KEY
3	WHITE	VMC RECEIVE/DEX TRANSMIT DATA (RING)
4	GREEN	DEX COMMON

SECTION 2. VENDER COMPONENT EXPLANATION

Primary Temperature Sensor (**Position P12**): The wiring harness connecting to this pinout travels from the Temperature Sensor to the Control Board. The Temperature Sensor is mounted on the rear tank above the evaporator fan. This harness is molded into the Temperature Sensor and should never be cut, pinched, or spliced together if cut. If the harness is cut, pinched, or improperly grounded, the sensor may give the Control Board false temperature readings. Refrigeration activity is based on the signal reported to the Control Board from this sensor (Pin 2).

PIN NUMBER	WIRE COLOR	FUNCTION
1	BLACK	TEMP. SENSOR 5 VOLT DC SUPPLY
2	KEY	KEY
3	WHITE	TEMP. SENSOR, SIGNAL
4	RED	TEMP. SENSOR 5 VOLT RETURN TO COMM.

Auxiliary Temperature Sensor (**Position P13**): This pinout may be available in the future, but as of this Service Manual printing it is not available.

PIN NUMBER	WIRE COLOR	FUNCTION
1	-	-
2	-	-
3	-	KEY
4	-	-

Environmental Controls (**Position P14**): The wiring harness connecting this pinout powers the Refrigeration Relay (to power the refrigeration unit). It is also responsible for powering any optional relays, such as the Refrigeration Heater Relay, Evaporator Fan Relay, Illumination (sign lighting) Relay, and a 24 volt DC counter. It powers each relay and counter by providing a constant 24 volts DC to each relay from Pin 1. Upon activation, the Control Board will remain neutral for each relay, or counter, from either Pin 2, 3, 4, 6 or 7.

PIN NUMBER	WIRE COLOR	FUNCTION
8	-	24 VOLT REGULATED DC
7	-	IMPULSE COUNTER
6	2X6	FLUORESCENT LIGHT RELAY
5	KEY	FAN RELAY OUT
4	2X4	FAN RELAY
3	2X3	COMPRESSOR RELAY
2	2X2	HEATER RELAY
1	2X1	24 VDC

24 Volt AC Power In (**Position P15**): The two (2) wire harness connecting this pinout come from the Low Voltage Transformer. It is imperative the correct harness be connected to this pinout. If this harness is not connected (or if power is lost to this connection), you will noticeably lose all Vender functions (except main door lighting) including power to your LED display. Power to your Coin Mechanism will not accept coins. Power to your Refrigeration System (compressor and condenser fan motor also will not run). With this connector, the wire harness can be in either position and the Control Board will not be affected.

PIN NUMBER	WIRE COLOR	FUNCTION
1	-	24 VOLT AC
2	-	NEUTRAL

SECTION 2. VENDER COMPONENT EXPLANATION

Low Voltage Transformer

(Run 1476 and after will have a fuse between the transformer and the Control Board)

The MERLIN IV Vender uses a low voltage (75 VA) transformer which reduces 110 volts AC (conventional voltage) to 24 volts AC, to power the Vender's Control Board. The transformer is a major contributor to the Vender's operation. Without the transformer, the Control Board cannot function.

LOCATION OF TRANSFORMER: In a CDC (Center Door Changer) Vender, the transformer is located below the Control Board. The fuse is fastened to the Changer Plug Bracket. In a non-CDC Vender, the transformer and fuse are located at the top of the main door.

OPERATION: The transformer has a three (3) amp external fuse on a secondary circuit to protect the Control Board and the Coin Mechanism. If the transformer fuse blows, you will lose power to the Control Board, noticeably losing power to the LED Display, and also losing power to the Coin Mechanism (Coin Mechanism will not accept coins and Bill Validator will not accept a bill). If you have a problem similar to this, follow the procedures listed below.

OPERATION REQUIREMENTS: The transformer operates by receiving 110 volts AC from the Vender (black and red wires). It transforms the 110 volts AC into 24 volts AC which is what the Control Board requires for its operation.

CHECK THE TRANSFORMER AND FUSE: If upon arriving at a Vender, the LED display is not lit and the coin changer does not take coins or payout coins, make sure the Vender is plugged in. Next check the transformer's external fuse for visual damage. Check for continuity across the fuse with a voltage meter or similar device. If defective, replace the external fuse.

Note: Merlin IV Venders made before run 1476 use an internal fuse in the transformer.

1. Check the power going into the transformer at the connected red and black wires. It should register 110 volts AC. If not, you need to check all wiring leading up to this point from the bottom of the Vender's main door. The transformer may not be the problem. You may have a broken wire or a bad connection.
2. If 110 volts is registered during Step 1, you want to measure voltage at the other end of the transformer. The two (2) pin connector at the Control Board connected to position P15 should register approximately 24 volts AC at this end of the harness. If so, check the Control Board; the transformer is good.
3. If 110 volts is registered during Step 1 and 24 volts AC is not registered during Step 2, you probably have a bad transformer. Unplug the Vender and transformer connections at the transformer (110 volt side). Unplug the transformer from the Control Board and remove it from the Vender's main door by locating the side of the transformer that has two (2) "built-in" wires going into the plastic housing.
4. Test the sensor by hitting the center of the delivery chute while watching the Control Board's Sensor Adjustment Indicator Lamp. The light should blink solidly upon impact.

SECTION 2. VENDER COMPONENT EXPLANATION

Delivery Chute Sensor

(Adjustment)

ADJUSTMENT: Located below the Sensor Connector is the Sensor Adjustment Trimpot, which includes an adjustment screw. The trimpot is used to adjust and fine tune the sensor. It is capable of turning both clockwise and counter-clockwise. Located directly above the trimpot is the Sensor Adjustment LED Indicator Light. The indicator light is mainly used to aid in adjusting the sensor but can also be used to test its operation during product impact.

1. Turn the adjustment screw clockwise until the indicator light comes on.
2. Turn the screw counter-clockwise until the light just goes out.
3. Continue to turn the screw counter-clockwise one turn. *Note: Slight adjustments may be needed outside the factory set one turn. Turning the adjustment screw clockwise makes the sensor more sensitive and counter clockwise makes it less sensitive. Test vend after every 1/4 turn.*

For Multiple Vending from all columns, make sure the sensor is adjusted to the Factory specifications as listed above. Next, turn the adjustment screw clockwise 1/4 turn to increase sensitivity. Test vend 7-12 columns, watch light on the board for a good on and off flash. If still Multiple Vending, turn the adjustment screw an additional 1/4 turn clockwise until proper adjustment is made.

For Dry Vending from all columns, make sure the sensor is adjusted to the Factory specifications as listed above. Next, turn the adjustment screw counter-clockwise 1/4 turn to decrease sensitivity. Test vend all columns. If still Dry Vending, turn the adjustment screw an additional 1/4 turn counter-clockwise until proper adjustment is made.

TESTING THE DELIVERY CHUTE SENSOR: Make sure the Vender is plugged in and the Controller has power (the LED display on the front of the Vender will be lit and the Coin Mechanism will accept coins). The Sensor Indicator Lamp will blink upon impact on the delivery chute. Lightly tap the chute with a tool, or your

fist, to simulate a can drop.

1. Locate the Sensor Adjustment Indicator Lamp on the lower right corner of the Vender's Control Board. Under normal conditions (as in stand-by), the lamp should be off.
2. Test the sensor by vending from column 7 and 12 while watching the Control Board's Sensor Adjustment Indicator Lamp. The light should blink solidly upon impact. If not, turn the sensor adjustment screw clockwise in 1/4 turn increments (to increase the sensitivity) and test after each turn. If the indicator lamp still does not light, turn the adjustment screw clockwise for many turns. If the indicator lamp does not light, change the sensor (assuming the Control Board has power and is working).
3. If the Sensor Adjustment Indicator Lamp lights properly during Step 2, change the Control Board.

SECTION 2. VENDER COMPONENT EXPLANATION

Refrigeration System

Your Vender's Refrigeration System comes as a completely sealed unit and should never be cut or tapped into or the warranty will be voided.

IDENTIFICATION: The refrigeration unit is responsible for the cooling of your sealed cabinet and the products loaded within it. The refrigeration unit's base plate (compressor, condenser coils and condenser fan motor), are mounted in the bottom (warm) section of the Vender's cabinet. The heat exchange or suction line extends into the upper (cold) section of the Vender's cabinet, where the evaporator coil is mounted in front of the evaporator fan motor.

OPERATION REQUIREMENTS:

The Refrigeration System requires 110 volts AC from the main wiring harness for it to operate. The main wiring harness will get its voltage for the unit from the Refrigeration Relay (electronic control) or from the thermostat (conventional control).

OPERATION: The rising temperature in the cooling compartment is reported to the Control Board from the Temperature Sensor. (See Figure 2.3) The Control Board registers the current temperature inside the Vender's cabinet. When it rises equal to, or above the pre-programmed cut-in temperature, the Control Board will then complete the circuit to the Refrigeration Relay to energize its coil (shown in Fig. 2.3 as CR-1). The Refrigeration Relay Coil energizes and closes the contact between the common and normally open positions (shown in Fig. 2.3 as CR1-1). This allows power (110 VAC) to travel through the Refrigeration Relay Switch and to the main wiring harness. The main wiring harness will power the unit immediately.

When the Compressor is powered, it circulates refrigerant throughout the system by pulling low pressure refrigerant vapor from the Evaporator Coil through the suction line into the Compressor. The Compressor compresses it, and forces it through the discharge line into the Condenser Coil.

The Condenser, aided by the Condenser Fan Motor, removes heat from the refrigerant as it flows through the Condenser Coil and releases it to the outside environment. The dropping of the refrigerant temperature changes the vapor to liquid.

The Evaporator Coil allows the liquid refrigerant to absorb heat from the cooling compartment as it evaporates in the coil. The falling temperature in the cooling compartment is caused by the continual circulation of refrigerant through the system, removing heat from the cooling compartment, and transporting it to the outside environment.

As the temperature drops, the temperature sensor reports this to the Vender's Main Control Board. When the temperature drops below the preset cut-out temperature, the Control Board will disable the Refrigeration Relay. This will break the Refrigeration Relay Switch connection (shown in Fig. 2.3 as CR1-1), thus canceling power to the refrigeration unit.

REFRIGERATION COMPONENTS: The Refrigeration System is a sealed system. Cutting or tapping into it will void all the manufacturer's warranty. Described in this section are explanations of the Refrigeration System's major components.

Cooling Compartment - The Cooling Compartment is the sealed area of the Vender holding the product for delivery. This area is designed to allow free flowing air to circulate throughout the product.

Compressor - The Compressor is a hermetically sealed unit located beneath (outside) the cooling compartment. The Compressor is a pump, driven by the Compressor motor which draws low pressure vapor (refrigerant) from the Evaporator Coil, compresses it, and forces it into the Condenser under high pressure. The motor is started and controlled by the temperature control.

Condenser - The Condenser is located beneath (outside) the cooling compartment next to the Compressor (it can be seen from the front with the door open). The Condenser removes heat from the high pressure vapor discharged from the Compressor and condenses it to a high pressure liquid. The Condenser and Evaporator Coils have aluminum fins attached to effectively increase heat exchange surfaces.

Starting Relay - The Starting Relay is mounted on the side of the Compressor Housing. The Compressor Motor has two windings: a start and a run winding. To give the motor torque when it first starts, the Starting Relay Switches in the additional start winding. After the motor gets up to speed, the relay opens the start winding and the motor continues using only the run winding.

SECTION 2. VENDER COMPONENT EXPLANATION

Thermal Overload - The Thermal Overload is a heat sensitive device mounted on the side of the Compressor Housing. If the Compressor Motor gets too hot, or draws an excessive amount of current, the Thermal Overload will open, breaking the circuit to the Compressor. After the Compressor cools to a safe operating temperature, the Thermal Overload will close allowing the Compressor and Condenser fan motors to restart.

Condenser Fan and Motor - The Condenser Fan and Motor, located beneath the cooling department, are a forced air device using outside ambient air to cool the surface of the Condenser Coil. The Condenser Fan and Motor run while the Compressor operates.

Evaporator Coil - The Evaporator Coil is located in the cooling compartment. As low pressure liquid passes through the Evaporator Coil, it absorbs and removes heat from the compartment as it changes to vapor. The Condenser and Evaporator Coil have aluminum fins attached to effectively increase their heat exchange surfaces.

Evaporator Fan and Motor - The Evaporator Fan and Motor are a forced air device circulating air throughout the cooling compartment and over the heat exchange surface of the Evaporator Coil. The Evaporator Fan and Motor run continually.

Capillary Tube - The Capillary Tube is located in the refrigerant line, between the Condenser and Evaporator Coil. The small diameter tube is used as a metering device to control the flow of liquid refrigerant to the Evaporator Coil. This creates low pressure causing the refrigerant to vaporize and absorb heat as it passes through the Evaporator Coil.

Drier - The Drier is located in the refrigerant line between the Capillary Tube and Condenser. It traps and removes moisture from the Refrigeration System while allowing oil and refrigerant to pass through the system.

Accumulator - The Accumulator is located in the refrigerant line between the Evaporator Coil and Compressor. The Accumulator traps any liquid refrigerant which did not vaporize before it reached the Compressor.

Refrigeration Relay - The Refrigeration Relay is located in the lower section of the Vender's cabinet near the main wiring harness. It takes

the place of the Temperature Control (thermostat) used over the past several years in "electro-mechanical" Venders. The Refrigeration Relay is responsible for powering the Compressor and Condenser Fan Motors. The Refrigeration Relay consists of a coil powered by the Control Board (24 volts DC) and a double-pole switch. When the Control Board completes the circuit to the Refrigeration Relay, the Relay will energize, closing the contact between the common and the normally open positions. When this happens, power (110 volts) travels from the Refrigeration Relay to the main wiring harness for the refrigeration unit.

REFRIGERATION CYCLE:

1. The rising temperature in the cooling compartment is reported to the Control Board through the Temperature Sensor.
2. The Control Board registers the current temperature inside the Vender's cabinet. When it rises equal to, or above the pre-programmed cut-in temperature, the Control Board will complete the circuit to the Refrigeration Relay to energize its coil.
3. The Refrigeration Relay coil closes the contact between the common and normally open positions allowing 110 volts to travel to the main wiring harness to start the Compressor.

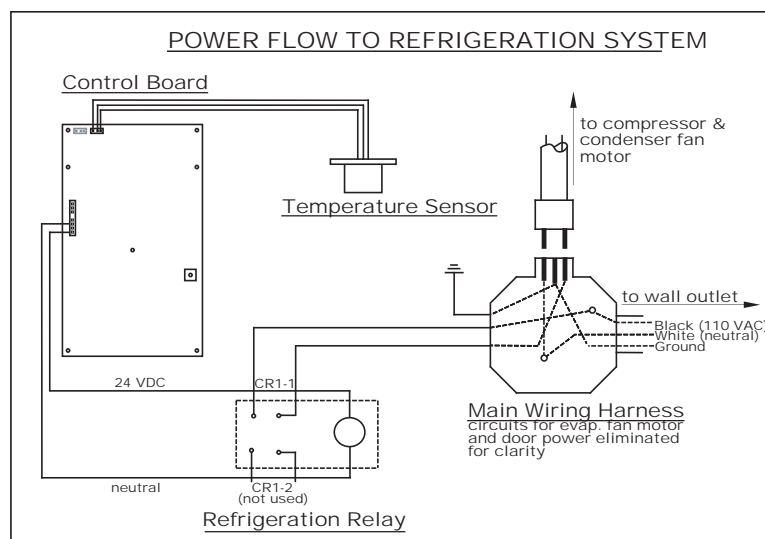

Figure 2.3

SECTION 2. VENDER COMPONENT EXPLANATION

4. The Compressor circulates refrigerant throughout the system by pulling low pressure refrigerant vapor from the Evaporator Coil, compressing it, and forcing it into the Condenser. The Condenser, aided by the Condenser Fan Motor, removes heat from the refrigerant as it flows through the Condenser and releases it to the outside environment. The dropping of the refrigerant temperature changes the vapor to liquid.
5. The Evaporator Coil allows the liquid refrigerant to absorb heat from the cooling compartment as it evaporates in the coil.
6. The falling temperature in the cooling compartment is caused by the continual circulation of refrigerant through the system, removing heat from the cooling compartment and transporting it to the outside environment. When the temperature drops, the Temperature Sensor reports this to the Vender's Control Board.
7. When the temperature drops below the preset cut-out temperature, the Control Board will disable the Refrigeration Relay, thus killing power to the refrigeration unit.

TESTING THE REFRIGERATION SYSTEM:

1. The sealed refrigeration unit can be tested by unplugging it from the top of the main wiring harness and plugging it directly into a power source. If the unit still does not operate, a problem exists within the sealed unit.
2. If the sealed refrigeration unit runs when plugged into an external power source, the problem more than likely lies between the Control Board, the Refrigeration Relay, and the main wiring harness. For troubleshooting this circuit, refer to Section 6, Vender Maintenance: Troubleshooting Refrigeration Problems.

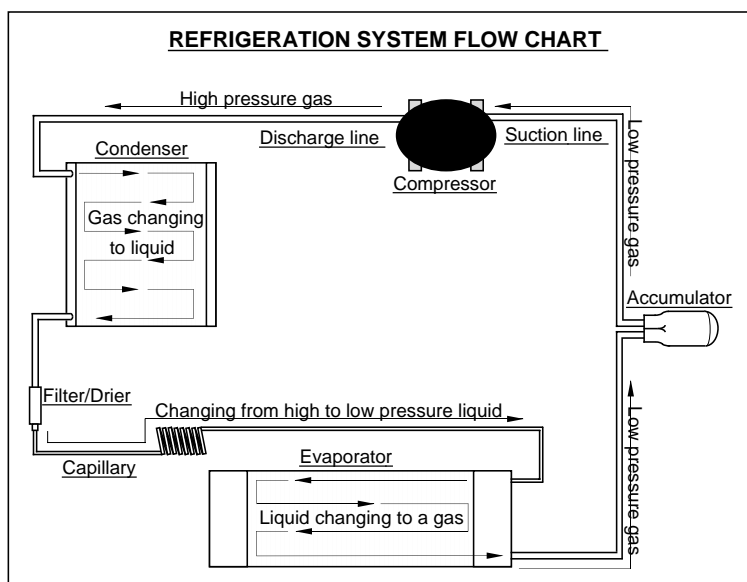

Figure 2.4

SECTION 3. VENDER PROGRAMMING

Vender Programming

THE NECESSITY OF CORRECT PROGRAMMING

Your MERLIN IV Vender must be programmed correctly for it to operate properly. There are other modes that may not interfere with normal operation of the Vender; or you may not notice the abnormal operation (if they are not programmed properly). As a whole, improper programming could cause the following problems:

MODE	PROBLEM SEEN
Pric	Wrong prices, even free vending
StoS	Columns not vending or wrong columns vending
Con	Vender options such as forced vend/escrow not working properly
SdEP	Vender multiple vending or "long" vend cycles
StCL	If enabled with use of timer or key switch will disable selections
tinE	Will disable selections or Refrigeration System if turned on
FriG	Will keep the unit from running or allow warmer/colder temperatures
PAS	Will keep you from accessing the external password mode
LAnG	Will display different languages for display messages

PRECAUTIONS TO TAKE WHEN WORKING WITH CONTROL BOARD

As with any printed circuit board, our electronics are very sensitive to Electrostatic Discharge (ESD). Simply walking across a tile, or carpeted floor, can generate a range of 30,000 to 50,000 volts of electricity. One ESD can be enough to seriously damage your Control Board; or at least weaken it enough that "erratic problems" could occur in the future. Even a discharge surge under 100 or 200 volts is enough to create shorts, or problems, within the circuitry of the electronics. It is advised when storing the electronics that they be kept in their anti-static bags, even if the electronics are thought to be defective. If a Control Board is thought to be defective and is really not, it soon will be after being charged with ESD. The ideal prevention against ESD is to use anti-static conductive wrist straps which ground you to the machine before

touching the electronic boards. If it is not possible to use these, at least ground yourself before handling the electronic boards. Whatever method you use, always handle the electronic boards by the edges. Be careful not to touch the components on the Control Board.

INTRODUCTION TO PROGRAMMING

As mentioned earlier in "The Necessity Of Correct Programming," it is very important your Vender is programmed properly. To do this, you must understand how the system works and what it takes to program your Vender. As you will see, after you are able to program one or two modes, you will be able to use similar procedures to program all modes.

MANEUVERING THROUGH LEVELS - The first step to understanding MERLIN IV programming is to learn how to negotiate through and around the menu levels to accomplish your task. To maneuver through the menu levels you must use the select buttons on the front of your Vender. Certain buttons have different meanings. You will use these buttons to move "up" or "down" through the menus. You will also use certain buttons to enter onto a new menu level or to home back to a previous level. These four (4) meanings that we have just mentioned are listed below, along with the active button for each.

NOTE: Programming Flowchart located in rear of manual

BUTTON	MEANING	FUNCTION
1	UP	Increase, Next, Etc.
2	DOWN	Decrease, Previous, Etc.
3	ENTER [press and release, less than two (2) seconds]	Save, Accept, OK, Etc.
3	HOME [press & hold for two (2) seconds or greater]	Exit, Escape, Return, Etc.

MENU SYSTEM - When programming, you must first use the three programming buttons listed above to maneuver through menus and sub-menus before you will be allowed to accomplish your task. Each menu consists of various items, or modes, such as the "Pric" Mode (Selection Price Setting Mode) or the "StoS" Mode (Space to Sales Setting Mode). There are currently two different main menus available.

1. **INTERNAL (Service) MENU:** This menu is available only with the Vender's main door open. It is accessed upon pressing the Control Board's mode button.

SECTION 3. VENDER PROGRAMMING

This menu contains all the programming modes, such as the Selection Price Setting Mode and Space to Sales Mode.

2. OPTIONAL MENU: This mode is available when Con 2 is set to "1".

Menu Levels

INTERNAL (Service) MENU

MODE DESCRIPTION

CASH	Cash Counter Mode: Used to access the total and individual cash counts.
SALE	Sale Counter Mode: Used to access the total and individual vend counts.
Error	Errors Mode: Used to read and clear Vender errors.
tES	Test Vend Mode: Used to free test vend from columns .
Pric	Price Setting Mode: Used to program selection prices.
StoS	Space to Sales Mode: Used to program columns to vend from select buttons.
SdEP	Set Vending Depth: Used to program vending depth per selection.
Con	Configurations Mode: Used to set Vender options.
rtm	Return to Sales: Used to return to the sales (greeting) mode (if Con 2 is set to "0").

Optional Menu (if Con 2 is set to "1")

ECO	Exact Change Only Mode: This mode controls the Exact Change Only light.
CPO	Coin Payout Mode: Used to payout coins from Coin Mechanism.
tUFL	Tube Fill Mode: Used to fill Coin Mechanism tubes.
dSAL	Discounted Sale Counter: Used with discount prices or free vend switch.
diFc	Discounted Differential Cash Counter: Used with discount prices or free vend switch.

SdiS	Set Discount Pricing: Automatically reduces vend prices during the day (uses timer).
StCL	Set Timer Controlled Selections: Used to choose the selections to turn on / off.
tinE	Timer Mode: Used to program on / off times for selections, refrigeration and lighting.
FriG	Refrigeration Mode: Used to adjust temperatures and test refrigeration operation.
PAS	External Password Mode: Used to set a password to access External Menu
LAnG	Language Mode: Used to change the display to international languages.
rtm	Return to Sales: Used to return to the sales (greeting) mode (door closed state).

EXTERNAL MENU

MODE DESCRIPTION

SALE	Sale Counter Mode: Used to access the total and individual vend counts.
rtm	Return to Sales: Used to return to the sales (greeting) mode (door closed state).
Error	Errors Mode: Used to read and clear Vender errors.

SECTION 3. VENDER PROGRAMMING

Internal Menu

Opening the Vender's main door and pressing the Control Board's mode button will allow you to access the Internal Menu. This section completely outlines all the Internal Menus, including descriptions and operation instructions for each mode. *After five (5) minutes without activity, the Control Board will revert to the Sales Mode (the LED will show the greeting).*

Note: *The following menu order pertains to 67100-7 and higher control board.*

CASH Cash Counter Mode (CASH)

This mode allows you to manually extract the amount of cash taken into the Vender through product sales (up to \$999,999.99). The Cash Counter Mode consists of a total count which is non-resettable. Individual selection counts are resettable, depending upon the proper configuration setting (see Configurations). The counts will be preceded by the count type (CL=cash level) and can be displayed in one (1) or two (2) sets of four (4) digits. Examples for both types of cash counters are:

Count Type	Actual Count	1 st Display	2 nd Display	3 rd Display
Total Cash Count	\$56,789.10	"CASH"	"567"	"89.10"
Selection Cash Count	\$6,789.10	"CL [number]"	"67"	"89.10"

OPERATION: If **<enter>** is pressed when the display shows "CASH", the Controller will enter the Cash Counter Mode. The display will flash "CASH" and the total amount of cash taken into the Vender. This can be shown in two (2) sets of four (4) digits (see Example 1 above). Using **<up>** or **<down>** will cycle through individual selection cash counts for each. The display will flash individual selection counts (as shown in Example 2 above). If **<home>** is pressed anytime during this operation, the Controller will return to the "CASH" display. From "CASH" pressing **<down>** will take you to "rtn". Pressing **<up>** will take you to "SALE".

CLEARING INDIVIDUAL COUNTERS: If the Configurations Mode is set to allow the individual counters to be reset, the individual counters will reset upon reading at least one of them and closing the Vender's main door (actuating the Vender's door switch).

SALE Sale Counter Mode (SALE)

This mode is very similar to the Cash Counter Mode. The Sale Counter Mode allows you to manually extract the amount of product vended from your Vender (up to 99,999,999 vends). The Sale Counter Mode consists of a non-resettable total count and individual selection counts which are resettable, depending upon the proper configuration setting (see Configurations). The counts will be preceded by the count type (SL=sale level) and can be displayed in one (1) or two (2) sets of four (4) digits. Examples for both types of sale counters are:

Count Type	Actual Count	1 st Display	2 nd Display	3 rd Display
Total Sale Count	5,678,910	"SALE"	"567"	"8910"
Selection Sale Count	678,910	"SL [number]"	"67"	"8910"

OPERATION: If **<enter>** is pressed when the display shows "SALE", the Control Board will enter the Sales Counter Mode. The display will flash "SALE" and the total amount of sales made by the Vender. This can be shown in two (2) sets of four (4) digits (see Example 1 above). Using **<up>** or **<down>** will cycle through individual selection sale counts. The display will flash individual selection counts (as shown in Example 2 above). If **<home>** is pressed anytime during this operation, the Controller will return to the "SALE" display. From "SALE" pressing **<down>** will take you to "CASH". Pressing **<up>** will take you to "Error".

CLEARING INDIVIDUAL COUNTERS: If the Configurations Mode is set to allow the individual counters to be reset, the individual counters will reset upon reading at least one of them and closing the Vender's main door (actuating the Vender's door switch).

Error Errors Mode (Error)

This mode was designed to help diagnose Vender problems. Upon opening the Vender's main door, the LED will flash any possible errors. (For a list, refer to Section 6, Vender Maintenance: Error Codes.) If there are no errors, the display will flash "none" and after five (5) minutes of no activity will revert to the sales greeting (ICE COLD). The Errors Mode was designed to give a detailed description of each error and allow you to clear errors.

SECTION 3. VENDER PROGRAMMING

OPERATION: If **<enter>** is pressed when the display shows “Error”, the Controller will enter into the errors descriptive display mode. At this point, the display will show any and all current Vender errors followed by the descriptive errors for each. If no errors exist, “none” will appear on the display but will revert back to the sales greeting after five (5) minutes of no activity. If **<home>** is pressed anytime during this operation, the Controller will return to the “Error” display. From “Error” pressing **<down>** will take you to “SALE” and pressing **<up>** will take you to “tEst”.

CLEARING ERRORS: To clear an error, wait until the error to be cleared is shown on the LED display. Then immediately press the **<up>** or **<down>** button and hold it in for at least two (2) seconds and the error will disappear. Follow this procedure for each error.



Column Test Vend Mode (tEst)

This mode is used to vend test by column, not by selection. After entering into this mode, you will have to pick the column which is desired to be tested. By pressing the **<enter>** button, the Control Board will vend from that column. No money is needed. This mode will test the Control Board’s ability to distribute 24 volts DC to the proper vend motor upon command. It will also test the mechanical part of the vending circuit, such as the vend motor and rotor. It does not test the Control Board’s coin acceptance/credit/payout circuit. **OPERATION:** If **<enter>** is pressed when the display shows “tEst” the Controller will enter the Column Vend Test Mode. The display will show “CO 1” (Column 1). Using **<up>** or **<down>** will cycle you through all the available columns to be test vend (the display may show some columns that are not in your Vender; nothing will happen if a test vend is attempted from these columns.). If **<enter>** is pressed, the Controller will attempt to test vend from the column which is being displayed. If a vend is not in progress, pressing **<home>** will return you to the “tEst” display. From “tEst”, pressing **<down>** will take you to “Error”. Pressing **<up>** will take you to “PriC”.

Note: Test vends will not affect cash or sale counters.



Selection Price Mode (PriC)

This mode is used to set vend prices. Depending on the Configurations Mode (discussed later in this Section), this mode will allow you to set either single or multi-pricing. When the configurations are set to allow single pricing, only one price has to be set in the “PriC” Mode (not individually). The current price will be

displayed on the LED display during the greeting. If the configurations are set to allow multiple pricing (per selection), the display will not show the vend price during the greeting unless all selections are set to the same price. You will have two options when setting prices:

- Multiple Pricing – “ALL” Pricing – Gives you the option to set one price for all selections.
- Individual Pricing – Allows you to set a different vend price for each selection.

If a free vend key switch is in use (turned-on), the display will scroll “FREE” during the greeting instead of the normal vend price. *(That is, if all selections are assigned in StCL mode.)*

OPERATION: If **<enter>** is pressed when the display shows “PriC”, the Controller will enter the price setting mode.

- Single Price Operation: The display will flash “SPri” and the current single price setting. This will be the single price viewing level. If **<enter>** is pressed again, the display will show the current single price only. If **<up>** is pressed or held, the price will increase in .05 increments. If **<down>** is pressed or held, the price will decrease in .05 increments. After the desired price has been set, press **<home>** to save your setting and return to the single price viewing level. Pressing **<home>** from the single price viewing level will return you to the display of “PriC”.
- Multiple Price Operation: The display will flash “ALL” followed by the last price set for all selections. If **<enter>** is pressed at this point, the display will steadily show the current “ALL” price. If **<up>** is pressed or held, the price will increase in .05 increments. If **<down>** is pressed or held, the price will decrease in .05 increments. After the desired price has been set, press **<home>** to save your setting and return to where the display flashes “ALL” followed by the new “ALL” price. You may now set a few, all, or different individual prices if desired.
- Individual Pricing: If **<up>** or **<down>** is pressed when the display flashes “ALL” followed by the current majority price setting, the display will cycle through the individual price settings for each selection. The display will flash the selection number followed by the price for that selection. Example: If selection one is set at fifty cents, the display will flash “P 1” followed by “.50”. Pressing **<enter>** while a individual selection is being displayed will cause the display to steadily show the

SECTION 3. VENDER PROGRAMMING

vend price for that selection to allow a change to the price. Press **<up>** to increase the price value in .05 increments or **<down>** to lower it in .05 increments. After the desired price has been set, press **<home>** to save your setting and return to where the display flashes “P X” followed by the new selection price. From “PriC”, pressing **<down>** will take you to “tESt”. Pressing **<up>** will take you to “StoS”.



Space to Sales Mode (StoS)

This mode is a very important part of programming. It will determine what column will vend upon pressing a particular select button. You will use this mode to program column assignments by assigning a column (or columns) to each selection button that you desire to use. You may also decrease the number of the Vender selections. Example: Your Vender has a total of ten (10) select buttons on the front panel. If you wish, you may program the controller to only use eight (8), seven (7), or six (6) selections (or even less). This is done by assigning all additional columns to one of the popular selections being used. A benefit of doing this is you will be allowed to allocate the “extra” columns to a “faster moving” flavor. Space to Sales Mode will come factory set for your type of Vender. Upon entering the Space to Sales Mode two different types of settings are available:

- Factory Standard Space To Sales: There are eight (8) factory preset settings from which to choose. These settings depend on how the “Con 12” Mode is set (for 12 or 10 columns, see Appendix A in the rear of the Manual).
- Custom Space To Sales: Allows you to custom configure any column to any selection

OPERATION: If **<enter>** is pressed when the display shows “StoS”, the Controller will enter the Space to Sales Setting Mode. The Control Board will always enter at the current Space to Sales Setting. If your Vender is programmed for custom Space to Sales, or if programmed with a Hand Held Computer, you will enter at “CStS”. If **<up>** or **<down>** is pressed at this point, you will be allowed to cycle through all Space to Sales Settings.

- Factory Standard Space To Sales: Pressing **<enter>** at any Factory Standard (“Opt”) Setting will “lock in,” or reprogram, the Control Board for that particular Space to Sales Setting. Upon doing this, the display will automatically start sequencing through each selection followed by all the columns that are assigned to each (see Example below). After each

selection has been shown, the display will return to “StoS”.

Example: If after entering a Factory Standard Setting the display flashes “SL 1”, and then flashes “1”, then flashes “2”, selection one has been assigned to Columns 1 and 2 only. This will occur for each selection.

- Custom Space To Sales: Pressing **<enter>** at “CStS” will allow you to enter the Custom Space To Sales Mode. Upon entering this mode, the display will always start by flashing “SL 1” (Selection 1) followed by flashing each column number assigned to this selection. Example: The display flashes “SL 1”, then flashes “1”, and then flashes “2”. Selection 1 has Columns 1 and 2 assigned to it only. Pressing **<up>** or **<down>** at this point allows you to cycle through Selections 1 through 12, with each selection showing the columns assigned to it. If **<enter>** is pressed at a selection, the display will show “Co 1”. This stands for Column 1 for that particular selection. Pressing **<up>** or **<down>** at this point will allow you to cycle through Columns 1 through 10 for the selection entered. If any column is flashing, this means it is assigned to the selection. If a column is *not* flashing, then it is *not* assigned to the selection. Pressing **<enter>** will change a column’s flashing condition. This allows you to assign or un-assign columns. If no changes are made, pressing **<home>** will return you to the Space to Sales Setting list at “CStS”. If a change to a selection is made, pressing **<home>** will return you to the selection level where the display flashes the selection number followed by the columns assigned to that selection. Follow this same procedure for all selections that you wish to program.

Important Note: Anything done in this mode will override any previously assigned Factory Standard or Custom Settings.

When completely finished in Custom Space to Sales Mode, pressing **<home>** will return you to “StoS” display. From “StoS” pressing **<down>** will take you to “PriC”. Pressing **<up>** will take you to “SdEP”.



Set Vending Depth Mode (SdEP)

Since the vend motors on a MERLIN IV Vender do not have cams or switches, programming electronically the vending depth is extremely necessary. With older style Electro-Mechanical Venders, it was necessary to adjust

SECTION 3. VENDER PROGRAMMING

the vend timing cam by either filling notches or rotating part of the cam to change the vending depth from triple or double to single depth. With the MERLIN IV Vender, you have a choice of either single or double depth for each selection **and not by column**. It is necessary to program the correct depth for each selection to prevent multiple or slow vends. For instance, if your actual vending depth is two and you program this selection for single depth, it will double vend every time.

OPERATION: If <enter> is pressed when the display shows “SdEP”, the Controller will enter the Set Vending Depth Setting Mode. The display will show “ALL”. From this point, two types of settings are available: the “All” depth setting enables you to set all depths the same (such as “ALL” of the price mode) and “Individual” depth setting gives you the option to set all depths individually for each selection.

- “ALL” Setting: If <enter> is pressed when the display shows “ALL”, the Controller will enter the Depth Setting Mode for “ALL” selections. The display will steadily show “ALL” and flash the current depth setting. Pressing <up> or <down> allows you to change the flashing depth setting between 1 or 2. Pressing <enter> will save changes and return you to where the display will show “ALL”. At this time, you will be able to cycle through each individual depth setting. Pressing <home> from this level will return you to the “SdEP” display.

Note: If you have selection depth settings that are different, but a majority of the settings are the same, it is advised to set the majority setting from within the “ALL” setting first. You will then be able to program the few settings that are individually different. This will cut down on program time.

- Individual Setting: If <up> or <down> is pressed when the display shows “ALL”, the Controller will cycle through each individual setting showing the selection number and the current setting. If <enter> is pressed while the display is showing an individual depth setting, the current setting starts flashing. Pressing <up> or <down> allows you to change the flashing depth setting between 1 or 2. Pressing <home> locks in your setting and returns you to the individual level at the point where you entered it (at the setting just changed). At this time, you will be able to cycle through each individual setting. Pressing <home> from the individual level returns you to the “SdEP” display. From “SdEP” pressing <down> will take you to “StoS”. Pressing <up> will take you to “Con”.



Configurations Mode (Con)

This mode is used to set Vender options dealing with pricing, acceptance, payback, and a few other optional features. While in the Configurations Mode, the display will show the configuration followed by the current setting. If the display shows “C 1 0”, this means Configuration 1 is currently set to 0. In other words, the Vender is set for single pricing. The configurations are as follows:

CONFIG.#	SETTINGS
C1	0 = Single Pricing
	1 = Multiple Pricing
C2*	0 = Hide Optional Menu Items
	1 = Show Optional Menu Items
C4	0 = Display errors or “nonE”
	1 = Display Sales, Cash Values, and existing error or “nonE”
C5	0 = No reset of individual counters
	1 = Allow reset of individual counts upon reading and door switch actuation
C6	0 = Credit will be returned if proper change cannot be made
	1 = Allow vend regardless of changer tube levels (change may not be paid)
C7	0 = Will allow bill acceptance regardless of payout availability
	1 = Will only accept a bill if coin tubes have enough coins to cover the difference between the bill value and the maximum vend price
C8	0 = Escrow to vend (will act as a bill changer)
	1 = Forced attempt (will not act as a bill changer)
C9	0 = Change is automatically returned to customer after a valid vend
	1 = Will hold the customer’s change in escrow to allow a multiple purchase
C10	0 = Bill escrow disabled
	1 = Bill escrow enabled
C11	0 = All errors displayed
	1 = Certain errors displayed
C12	0 = 12 column mode
	1 = 10 column mode

SECTION 3. VENDER PROGRAMMING

**Note: C2 - Version 67100-7 and after.*

OPERATION: If **<enter>** is pressed when the display shows “Con”, the Controller will enter the Configurations Mode. The display will show Configuration 1 and its setting (as listed in the Configurations Description). If **<up>** or **<down>** is pressed at this point, the display will cycle through each configuration. Pressing **<enter>** while the display shows a configuration, allows the current configuration setting to start flashing. Pressing **<up>** or **<down>** while the current configuration setting is flashing, allows you to toggle the configuration setting between 0 and 1. If changes are made to a configuration, pressing **<enter>** will return you to the Configuration List Level and save any change. Follow the above process for all configurations which you wish to set. When done, pressing **<home>** will return you to the “Con” display. From “Con”, pressing **<down>** will take you to “SdEP”. Pressing **<up>** will take you to “rtn” if C2 is set to “0”, or to “ECO” if C2 is set to “1”.



Return to Sales / Greeting Mode (rtn)

This mode is used to exit the Service Menu and return to the Sales Mode, where the display flashes the greeting (ICE COLD or PEPSI COLA) along with any other display options.

OPERATION: If **<enter>** is pressed when the display shows “rtn”, the Controller will revert to the Sales Mode and the greeting will be displayed. From “rtn”, pressing **<down>** will take you to “Con”. Pressing **<up>** will take you to “CASH”.

Optional Menu Items



Exact Change Value Mode (ECO)

This mode controls the Exact Change Only light. If the machine cannot make change for the value (or lower) specified in this mode, the Exact Change Only lamp will light.

Note: 67100-X Board and later versions

OPERATION: If **<enter>** is pressed when the display shows “ECO”, the Controller will enter the Exact Change Value Setting Mode. The display will show the exact change value. Pressing **<up>** or **<down>** allows you to

adjust the value. Pressing **<home>** will save the currently displayed value and return you to the “ECO” display. From “ECO”, pressing **<down>** will take you to “Con”. Pressing **<up>** will take you to “CPO”.



Coin Payout Mode (CPO)

This mode allows you to payout coins from the Coin Mechanism’s Tubes through the Control Board. This mode is mainly used because some types of coin mechanisms do not have payout buttons (switches) on them. This can also be used as a test to confirm the Control Board’s ability to payout coins (will payout the same as after a sale).

OPERATION: If **<enter>** is pressed when the display shows “CPO”, the Controller will enter the coin payout mode and display the lowest coin value (.05). Using **<up>** or **<down>** will allow the user to cycle through all coin values available for payout. If **<up>** or **<down>** is pressed and held at this point, a coin of the displayed value will be paid out. The word “PAY” will be displayed as coins are paid out. Coins will continue to payout as long as **<up>** or **<down>** is held. If **<home>** is pressed anytime during this operation, the Controller will return to the “CPO” display. From “CPO”, pressing **<down>** will take you to “ECO”. Pressing **<up>** will take you to “tUFL”.

Note: If you are using the “tUFL”, you must use the “CPO” Mode to payout coins.



Coin Tube Fill Mode (tUFL)

This mode is used to keep inventory of the exact coin tube levels as each coin is inserted. During this mode, the LED display will register each coin as it is inserted (in no particular order) and report its value to the Vender’s Control Board. The Control Board will in turn remember the Coin Mechanism’s coin tube levels and automatically deduct a coin each time a coin is paid out (through “CPO” Mode or during a vend.). This mode can only be used if a Multi-Drop Bus Coin Mechanism is in use.

OPERATION: If **<enter>** is pressed when this display shows “tUFL”, the Controller will enter the Coin Tube Fill Mode. The LED display will go blank allowing the deposit of nickels, dimes, or quarters through the coin insert or coin acceptor inlet chute. If **<home>** is pressed anytime during this operation, the Controller will return to the “tUFL” display. From “tUFL”, pressing **<down>** will take you to “CPO”. Pressing **<up>** will take you to “dSAL”.

SECTION 3. VENDER PROGRAMMING

Note: The use of the Coin Mechanism's Manual Coin payout buttons is discouraged to keep from corrupting the coin counts. As long as the sales greeting is scrolling, the manual buttons cannot be used.

Discounted Sale Counter Mode (dSAL)

This mode is very similar to the Sale Counter Mode. It allows you to manually extract the amount of product dispensed through your Vender during the discounted sales periods (up to 99,999,999). The Sale Counter Mode consists of a non-resettable total count and individual count per selection which are resettable, depending upon the proper configuration setting (see Configurations). The counts can be displayed in up to two (2) sets of four (4) digits. Examples for both total and individual counters are:

Discount Count Type	Actual Count	1st Display	2nd Display	3rd Display
Total Sale Count	5,678,910	"SALE"	"567"	"8910"
Selection Sale Count	678,910	"SL [number]"	"67"	"8910"

OPERATION: If **<enter>** is pressed when the display shows "dSAL", the Controller will enter the Discounted Sales Counter Mode. The display will flash "SALE" and the total amount of discounted sales made by the Vender. This can be shown in two (2) sets of four (4) digits (as shown in Example 1 above). Using **<up>** or **<down>** will cycle through individual discounted sales counts for each selection. The display will flash individual counts (as shown in Example 2 above). If **<home>** is pressed anytime during this operation, the Controller will return to the "dSAL" display. From "dSAL" pressing **<down>** will take you to "tUFL". Pressing **<up>** will take you to "diFc".

CLEARING INDIVIDUAL COUNTERS: If the Configurations Mode is set to allow the individual counters to be reset, the individual counters will reset upon reading at least one (1) of them and closing the Vender's main door or actuating the Vender's door switch.

Differential Cash Discounted Counter Mode (diFC)

This mode is comparable to the Cash Mode. It allows you to monitor the difference between discounted prices and regular prices. The Differential Cash Discounted Counter Mode is a non-resettable total count. If product is sold for less than the vend price, the counts will be preceded by a negative symbol (-). If product is sold for greater than the vend price, the counts will be shown normally. Examples for both are:

Differential Count Type	Actual Count	1st Display	2nd Display	3rd Display
Differential Cash Count (Negative)	-\$789.10	"CASH"	"-7"	"89.10"
Differential Cash Count (Positive)	\$789.10	"CASH"	"7"	"89.10"

OPERATION: If **<enter>** is pressed when the display shows "diFC", the Controller will enter the Differential Cash Discounted Counter Mode. The display will flash "CASH" and the total difference between regular vend prices and discounted prices (as shown in Example 1 above). Pressing **<home>** anytime during this operation will allow the Controller to return to the "diFC" display. From "diFc", pressing **<down>** will take you to "dSAL". Pressing **<up>** will take you to "SdiS".

CLEARING INDIVIDUAL COUNTERS: This is a non resettable counter.

Set Discount Pricing Mode (SdiS)

This mode is used to set discount prices for each selection. This mode works in conjunction with the built-in timer in the "tinE" Mode. Before entering "tinE" Mode, you must set the selections to "1" in StCL Mode. After the StCL Mode you may set the discounted price for each desired selection. Then, set the time you wish the discounted selection to be activated by using the "dScn" settings in the "tinE" Mode under the day function.

SECTION 3. VENDER PROGRAMMING

OPERATION: If **<enter>** is pressed when the display shows “SdiS”, the Controller will enter the Discount Price Setting Mode. The display will flash “ALL” (for all selections) and flash the last discount price value that “ALL” was set at. This is referred to as the selection level. If **<enter>** is pressed at this point, the display will steadily show the discount value for all selections. Press **<up>** to increase the discount price value in .05 increments or **<down>** to lower it in .05 increments. If **<home>** is pressed after adjusting the price, your new discount price will be saved and the display will return to the selection level. You may now set a few, all, or different individual discount prices if desired. If **<up>** or **<down>** is pressed when the display flashes “ALL” (for all selections) then flashes the last discount price value that “ALL” was set at, the display will cycle through the individual discount price settings for each selection. The display will show the selection number followed by the discount price for that selection. Example: If selection one is set at fifty cents, the display will flash “P 1” followed by “.50”. Pressing **<enter>** while an individual selection is being displayed will cause the display to steadily show the discounted vend price for that selection to allow a change to it. Press **<up>** to increase the discount price value in the same fashion as above or **<down>** to lower it. Pressing **<home>** after adjusting a price will save that price and return you to the selection level. Pressing **<home>** while at the selection level will return you to the “SdiS” display. From “SdiS”, pressing **<down>** will take you to “diFc”. Pressing **<up>** will take you to “StCL”.

Set Timer Controlled Selections Mode (StCL)

This mode is used to choose the selections to turn off either using the built-in timer or with the optional key switch kit. This mode must be set to enable one or all of the selections for the timer or the key switch to operate. The timer or key switch will control any selections set to “1”. Selections set to “0” will function normally.

OPERATION: If **<enter>** is pressed when the display shows “StCL”, the Control Board will enter the Set Timer Controlled Selections Mode at the selection level and the display will show “ALL”. From this point, two types of settings are possible:

- “ALL” Setting: If **<enter>** is pressed when the display shows “ALL and the current setting”, the Control Board will enter the “ALL” Setting Mode. The display will steadily show “ALL” and flash the

current “StCL” setting. Pressing **<up>** or **<down>** allows you to change the flashing setting between 0 and 1. Pressing **<enter>** saves any change and returns you to the selection level where the display steadily shows “StCL” and the new setting. At this time you will be able to cycle through each selection to set individual settings. If completely done, pressing **<home>** from the selection level (display shows “ALL and current setting”) will return you to the “StCL” display.

- Individual Setting: If **<up>** or **<down>** is pressed when the display shows “ALL and the current setting”, the Controller will cycle through each selection showing the selection number and the current setting for that selection. Example: If the display shows “t 3 1” (for selection 3, the timer is set to on). If **<enter>** is pressed while the display is showing an individual selection timer setting, the current setting for that selection will start flashing. Pressing **<up>** or **<down>** allows you to change the flashing timer setting between 0 and 1. Pressing **<enter>** saves any change and returns you to the selection level. At this time you will be able to cycle through each selection to set other individual Timer Controlled Selection Settings. Pressing **<home>** from the selection level will return you to the “StCL” display. From “StCL”, pressing **<down>** will take you to “SdiS”. Pressing **<up>** will take you to “tinE”.

Notes: When pressing a selection in the StCL Mode:

- 1) Version 67100-3 and after, the LED will display “No Sale till XXXX” (XXXX represents the time set for the timer).
- 2) Version 67100-2 and prior, the LED will show the “Greeting”, and “Sold Out”.

Time and Timer Settings Mode (tinE)

This mode is used mainly to turn selections, lighting, and/or refrigeration off and back on during predetermined times of the day and days of the week. In the “tinE” Mode, you must set the current year, date, hour and day of the week for the timer to operate. The “tinE” Mode is also used to set each “on” and “off” time in which the timer will operate. Within the “tinE” Mode, there are several different functions listed below with a meaning and example for each.

SECTION 3. VENDER PROGRAMMING

FUNCTION	PROGRAM MEANING	DISPLAY EXAMPLE (After Entering Mode)
YEAr	Current Year	“1998”
daTE	Current Month/Day	“06.08” (June 8)
hour	Current Hour/Min.	“13.30” (1:30 pm) <i>military time</i>
SEtd	Set Day of the Week	“SUN”
StOP	Disable Clock*	“CLOC” then “StOP”
daY	Timer On/ Off Days and Times	“ALL”
dSt	Display Time On LED	“dSt” with setting flashing
dLt	Daylight Savings Time	“dLt” with setting flashing

* This feature is used to conserve the Control Board's built-in battery if Vender is in storage for long periods of time. The Lithium battery shelf life is three (3) years with the clock turned on and ten (10) years with it off.

OPERATION: If <enter> is pressed when the display shows “tinE”, the Controller will enter the Time and Timer Settings Mode and the display will show “YEAr”. Pressing <up> or <down> allows you to cycle through each “tinE” function. Pressing <home> while the display is showing any of the earlier listed “tinE” functions will return you to the “tinE” display. When completely finished with all “tinE” functions, pressing <home> from the “tinE” functions menu returns you to the code level where the display shows “tinE”. Pressing <down> will take you to “StCL”. Pressing <up> will take you to “FriG”.

- Year Function (“YEAr”): If <enter> is pressed when the display shows “YEAr”, the Controller will enter the year setting “tinE” function and the display will show the year, with the first two numbers of the year flashing (Example: 19.98). Pressing <up> or <down> allows you to change the first two digits of the year. If <enter> is pressed at this point, the first two numbers of the year lock in and the second set of digits start to flash (Example: 19.98). Pressing <up> or <down> allows you to change the second two digits of the year. Pressing <home> saves any change and returns you to the beginning of the year “tinE” function where the display shows “YEAr”. From “YEAr”, pressing <down> will take you to “dLt”. Pressing <up> will take you to “dAtE”.

- Date Function (“dAtE”): If <enter> is pressed when the display shows “dAtE”, the Controller will enter the date setting “tinE” function and the display will show the current date, with the first two numbers of the date flashing to indicate the month (Example: 03.00). Pressing <up> or <down> allows you to change the first two numbers of the date. If <enter> is pressed from this point, the first two numbers of the date lock in and the second set of two digits will start flashing to indicate the day (Example: 03.28). Pressing <up> or <down> allows you to change the second two numbers of the date. Pressing <home> anytime during this process saves any change and returns you to the beginning of the date “tinE” function where the display shows “dAtE”. From “dAtE”, pressing <down> will take you to “YEAr”. Pressing <up> will take you to “hour”.
- Hour Function (“hour”): If <enter> is pressed when the display shows “hour”, the Controller will enter the hour setting “tinE” function and the display will show the current hour in military time with the first two numbers of the hour flashing (Example: 14.00). Pressing <up> or <down> allows you to change the hour. If <enter> is pressed from this point, the first two numbers of the hour lock in and the second set of two digits will start flashing to indicate the minutes (Example: 14.31). Pressing <up> or <down> allows you to change the second two numbers of the hour. Pressing <home> after making a change will return you to the beginning of the hour “tinE” function where the display shows “hour”. From “hour”, pressing <down> will take you to “dAtE”. Pressing <up> will take you to “SEtd”.
- Set Day Function (“SEtd”): If <enter> is pressed when the display shows “SEtd”, the Controller will enter this mode displaying a day of the week. Pressing <up> or <down> allows you to change the day of the week. When the desired day is selected, press <home> to select and bring you to “SEtd”. From “SEtd”, pressing <down> will take you to “hour”. Pressing <up> will take you to “StOP”.
- Stop Function (“StOP”): If <enter> is pressed when the display shows “StOP”, the Controller will enter the Stop Clock Setting “tinE” function and the display will flash “CLOC” and “StOP”. Pressing <enter> will turn off the clock to reserve the Controller's built-in battery. The display will flash “Off” and automatically exit back to the display of “StOP”. Pressing <home> anytime during this

SECTION 3. VENDER PROGRAMMING

process will return you to the beginning of the Stop Clock “tinE” function where the display shows “StOP”. From the “StOP” display, pressing **<down>** will take you to “hour”. Pressing **<up>** will take you to “dAY”.

- Day Function (“dAY”): If **<enter>** is pressed when the display shows “dAY”, the Controller will enter the “tinE” function to allow you to set the timer on/off times for each day of the week. The display will show “ALL”. From this point you have two different options: the All Day Timer Setting will enable you to set all days the same in which the timer operates (such as “ALL” of the price mode) and Individual Day Timer Settings will give you the option to set all the timer operations different daily. Pressing **<up>** or **<down>** allows you to cycle from “ALL” to each day of the week. If **<enter>** is pressed, either at “ALL” or a week day, the Controller will enter into that particular day. The display will show “SC-1”, then “On”, and then the current first “Off” time for selections as listed below. From here on, this will be referred to as the Timer Setting Mode Viewing Only Level. If **<up>** or **<down>** is pressed at the Timer Setting Mode Viewing Only Level, the display will cycle to all other available Timer Setting Modes:

SETTING MODE	PROGRAM MEANING
“SC-1”... “On”	1 st OFF time for selections
“SC-1”... “Off”	1 st ON time for selections
“SC-2”... “On”	2 nd OFF time for selections
“SC-2”... “Off”	2 nd ON time for selections
“SC-3”... “On”	3 rd OFF time for selections
“SC-3”... “Off”	3 rd ON time for selections
“dScn”... “On”	ON time for discounted selections
“dScn”... “Off”	OFF time for discounted selections
“FriG”... “On”	OFF time for Refrigeration System
“FriG”... “Off”	ON time for Refrigeration System
“Lt-1”... “On”	1 st OFF time for illumination (ballast lighting)
“Lt-1”... “Off”	1 st ON time for illumination (ballast lighting)
“Lt-2”... “On”	2 nd OFF time for illumination (ballast lighting)
“Lt-2”... “Off”	2 nd ON time for illumination (ballast lighting)

“Lt-3”... “On”	3 rd OFF time for illumination (ballast lighting)
“Lt-3”... “Off”	3 rd ON time for illumination (ballast lighting)

To set “On” and “Off” times for the timer, you must press **<enter>** upon reaching the desired Timer Setting Mode. After doing this, the Controller will enter into that particular Timer Setting Mode. The display will show the current setting with the hour flashing. This indicates that the hour can now be changed. Pressing **<up>** or **<down>** allows you to change the hour of this particular setting. Pressing **<enter>** will lock in the hour setting and start the minutes flashing (which will indicate to you the minutes can now be changed). Pressing **<up>** or **<down>** allows you to change the minutes of this setting. Pressing **<home>** anytime during this process will lock in your changes and bring you back to where the display shows the Timer Setting Mode and the time set for that mode (Timer Setting Mode Viewing Only Level).

At this point, **<up>** or **<down>** allows you to access all Timer Setting Modes listed earlier. From this Timer Setting Mode Viewing Only Level, pressing **<home>** again will return you to the day of the week level. Press **<home>** again to return to the display of “dAY”. From “dAY”, pressing **<down>** will take you to “StOP”. Pressing **<up>** will take you to “dSt”.

Note: If you are setting certain selections to go off and come back on at a programmed time, you must first enter “SC-1 On” to set the first off time for selections. When done programming the first off time, you must then program the first return on time for the selections by entering into “SC-1 Off” and programming your return on time. For the timer to be able to control the selections, you must set the selections to be controlled in the “StCL” Mode of the Password Protected Menu.

- Display Time Function (“dSt”): If **<enter>** is pressed at this display, the Controller will enter the Display Time Setting Mode and the display will show “dSt” while flashing the current setting. Pressing **<up>** or **<down>** allows you to change the flashing setting back and forth between 0 and 1. If set to “1”, the time of day will be displayed on the LED during the greeting. If set to “0” the time will not be displayed during the greeting. Pressing **<home>** anytime during the process will save changes and return you

SECTION 3. VENDER PROGRAMMING

to the “dSt” display. From this point, pressing **<down>** will take you to “dAY”. Pressing **<up>** will take you back to “dLt”.

- Daylight Savings Time Function (“dLt”): This option allows for the automatic adjustment of Daylight Savings Time. If enabled, the time will automatically be adjusted forward one hour at 2:00 a.m. (2:02 a.m. at the latest) on the first Sunday of April and similarly adjusted back one hour on the last Sunday of October. If **<enter>** is pressed at this display, the Control Board will enter the Daylight Savings Time Enable / Disable Mode. The display will show “dLt” and flash the current setting. Pressing **<up>** or **<down>** allows you to change the flashing setting back and forth between 0 and 1. If set to “1”, Daylight Savings Time will be enabled. If set to “0”, Daylight Savings Time will be disabled. Pressing **<enter>** anytime during the process will save any change and returns you to the start of the Display Time Mode where the display will show “dLt”. From this point, pressing **<down>** will take you to “dSt”. Pressing the **<up>** button will take you to the “yEAR” mode.

Note: This is important if you are using the timer function set to “1”.

FriG Refrigeration Parameters Mode (FriG)

This mode is used to control the environmental aspects of the Vender. It controls the Refrigeration System by allowing you to program the cut in and cut out temperatures of the refrigeration unit. The “FriG” Mode also allows you to show the current inside cabinet temperature (on the LED during the greeting). The temperatures shown on the LED during the greeting and programming can be changed from Fahrenheit to Celsius. The “FriG” Mode has a relay mode allowing you to test any controlling relays in the Vender (evaporation fan, refrigeration, ballast, and heater). There is even a setting to disable the unit for safety reasons. Within the “FriG” Mode, there are several different functions listed below with a meaning and an example for each.

Note: The “FriG” Mode is only applicable in Venders using Electronic Refrigeration Mode. However, if the “FriG” setting is set to “1”, without the use of electronic control, the display will show unnecessary “FriG” errors.

Function	Program Meaning	Display Example (After Entering Mode)
Cuti	Cut In Temperature	41F
Cuto	Cut Out Temperature	29F
dEG	Select Fahrenheit Or Celsius	
dSP	Display Inside Cabinet (evap.) Temperature	
FriG	Master Control On/Off	
rELY	Relay Test Mode	

OPERATION: If **<enter>** is pressed when the display shows “FriG”, the Controller will enter the Refrigeration Parameters Mode and the display will show “Cuti”. Pressing **<up>** or **<down>** allows you to cycle through all six (6) “FriG” functions. When completely finished with all programming in the “FriG” Mode, pressing **<home>**, while the display is showing any of the earlier listed “FriG” functions, will return you to the “FriG” display. From “FriG”, pressing **<down>** will take you to “tinE”. Pressing **<up>** will take you to “PAS”.

- Cut In Function (“Cuti”): If **<enter>** is pressed when the display shows “Cuti”, the Controller will enter the Cut In Setting “FriG” function and the display will show the current Cut In Temperature Setting (Factory setting: 41°F). Pressing **<up>** or **<down>** allows you to change the Cut In Setting. The setting can be adjusted between 39°F to 45°F (4°C to 7°C). Pressing **<home>** anytime during this process will save any change and returns you to the beginning of the “Cuti” “FriG” function where the display shows “Cuti”. From “Cuti”, pressing **<down>** will take you to “rELY”. Pressing **<up>** will take you to “Cuto”.
- Cut Out Function (“Cuto”): If **<enter>** is pressed when the display shows “Cuto”, the Controller will enter the Cut Out Setting “FriG” function. The display will show the current Cut Out Temperature Setting (Factory setting: 29°F). Pressing **<up>** or **<down>** will allow you to change the Cut Out Setting. The setting can be adjusted between 24°F to 34°F (-4°C to 1°C). Pressing **<home>** anytime during this process will save any change and returns you to the beginning of the “Cuto” “FriG” function where the display shows “Cuto”. From “Cuto” pressing **<down>** will take you to “Cuti”. Pressing **<up>** will take you to “dEG”.

SECTION 3. VENDER PROGRAMMING

- Select Degree Function (“dEG”): If **<enter>** is pressed when the display shows “dEG”, the Controller will enter the Degree Setting “FriG” function. The display will show “dEG” and flash the current degree setting. Pressing **<up>** or **<down>** will allow you to change the current setting. Program to “F” for Fahrenheit (Factory Setting) or “C” for Celsius. Pressing **<home>** anytime during this process will save any change and returns you to the beginning of the “dEG” “FriG” function where the display shows “dEG”. From “dEG”, pressing **<down>** will take you to “Cuto”. Pressing **<up>** will take you to “dSP”.
- Display Temperature Function (“dSP”): If **<enter>** is pressed when the display shows “dSP”, the Controller will enter the Display Temperature “FriG” function. The display will show “dSP” and flash the current setting. Pressing **<up>** or **<down>** allows you to change the current setting. Program to “1” to display the temperature on the LED display during the sales greeting or “0” to not display the temperature during the greeting. Pressing **<home>** anytime during this process will save any change and returns you to the beginning of the “dSP” “FriG” function where the display shows “dSP”. From “dSP”, pressing **<down>** will take you to “dEG”. Pressing **<up>** will take you to “FrG”.
- Unit Disable (Master On/Off) Function (“FrG”): If **<enter>** is pressed when the display shows “FrG”, the Controller will enter the Unit Disable “FriG” function. The display will show “FrG” and flash the current setting. Pressing **<up>** or **<down>** allows you to change the current setting. Program to “1” (Electronic Refrigeration Factory Setting) for the refrigeration unit to operate normally or “0” to disable unit. Pressing **<home>** anytime during this process will save any change and returns you to the beginning of the “FrG” “FriG” function where the display shows “FrG”. From “FrG”, pressing **<down>** will take you to “dSP”. Pressing **<up>** will take you to “rELY”.
- Relay Test Function (“rELY”): If **<enter>** is pressed when the display shows “rELY”, the Controller will enter the relay “FriG” function to allow you to test the various Vender relays. The display will show “Fan” (which is the test mode for the optional Evaporator Fan Motor Relay). Pressing **<up>** or **<down>** allows you to cycle through each relay test mode available.

RELAYTEST MODEMENU	MEANING
Fan	Evaporator Fan Relay Test (requires optional kit)
Htr	Heater Relay Test (requires optional kit)
LitE	Illumination Relay Test (requires optional kit)
CnPr	Compressor Relay Test

If **<enter>** is pressed at any of the four (4) relay test modes, the display will flash the name of the relay and then flash off. If the relay is currently off and you wish to enable it, **<enter>** here. If not, pressing either **<up>** or **<down>** allows the display to flash the name of the relay and then flash off. If the relay is currently off and you wish to test the circuit by turning it on, **<enter>** here. If the circuit tested does not work, you have five (5) minutes in Test Mode to check voltage. Pressing **<home>** from within any relay Test Mode (if after a test) will allow you to return to the Relay Test Mode Menu (where the display will show the name of the relay menu you were just in). Pressing **<home>** from a point on the Relay Test Mode Menu returns you to the beginning of the Relay Mode (where the display shows “rELY”).



External Menu Password Setting Mode (PAS)

With the MERLIN IV Vender, you have the capability to access both total historical and individual selection can counts externally. You are also able to read Vender errors externally (errors cannot be cleared externally). The “PAS” Mode gives you the option to change the external password to any of your select buttons in a four-digit combination, or you may decide it best to use the factory setting of **1 - 3 - 2 - 4** (earlier software versions used **4 - 2 - 3 - 1**). If you do decide to set your own password and happen to forget it, just access this menu and the current password will be displayed.

HELPFUL HINTS

1. Password numbers range from 0 to 9.
2. If your Vender only has seven selections, you cannot use 8, 9, or 0 in your password or you will not be able to enter the password.

SECTION 3. VENDER PROGRAMMING

- To disable the external password, set one of the four (4) digits to “0” or a selection that is not available (as described in Hint #2).

OPERATION: If **<enter>** is pressed when the display shows “PAS”, the Controller will enter the External Password Setting Mode. The display will show the current external password with the first number of the four (to extreme left of display) flashing. Pressing **<up>** or **<down>** allows you to change the flashing digit. If **<enter>** is pressed, the second number from the left will start flashing. By doing this, you lock in any changes made to the first digit and you are now able to change the second digit. Follow the same process for every digit. If the fourth digit is flashing and **<enter>** is pressed, you will return to “PAS”. Pressing **<home>** any time during this process locks in your setting and returns you to the “PAS” display. From “PAS”, pressing **<down>** will take you to “FriG”. Pressing **<up>** will take you to “LAnG”.

LAnG International Language Setting Mode (LAnG)

The MERLIN IV Vender gives you the opportunity to set an international languages of English, French, Spanish, Hebrew, or German to show vending messages, such as “sold out,” to the customer.

OPERATION: If **<enter>** is pressed when the display shows “LAnG”, the Controller will enter the International Language Setting Mode. The display will show the current language being used. Pressing **<up>** or **<down>** allows you to change the language to one of the following:

EnGL English Language
HEbr Hebrew Language
FrEn French Language
GEr German Language
SPAn Spanish Language

Pressing **<home>** anytime during this process saves any change and returns you to the “LAnG” display. From “LAnG”, pressing **<down>** will take you to “PAS”. Pressing **<up>** will take you to “rtn”.

rtn

Return to Sales / Greeting Mode (rtn)

This mode is used to exit the Service Menu and return to the Sales Mode, where the display flashes the greeting (ICE COLD or PEPSI COLA) along with any other display options.

OPERATION: If **<enter>** is pressed when the display shows “rtn”, the Controller will revert to the Sales Mode and the greeting will be displayed. From “rtn”, pressing **<down>** will take you to “LAnG”. Pressing **<up>** will take you to “CASH”.

External Menu

By entering the correct four-digit password when Vender is in stand-by condition (display is showing the greeting, a credit is not established, and the Vender is not set for free vend), you will access the External Menu. This menu consists of three (3) menu items previously discussed in the Internal Menu. The External Menu is designed to give you access to a few features, such as total and individual (per selection) vend counts, Vender error diagnostics, and a clearing feature for individual vend counts. This menu may come in handy for a location manager who does not have access to the inside of the Vender but wishes to report problems and get vend counts. Programming CANNOT be done through this menu! *After five (5) minutes without activity, if money is inserted or if the coin return lever is actuated, the Control Board will revert to the Sales Mode (the LED will show the greeting).*

SALE

Sale Counter Mode (SALE)

This mode is very similar to the Cash Counter Mode. The Sale Counter Mode allows you to manually extract the amount of product vended from your Vender (up to 99,999,999 vends). The Sale Counter Mode consists of a non-resettable total count and individual selection counts. These are resettable depending upon the proper configuration setting (see Configurations). The counts will be preceded by the count type and can be displayed in one (1) or two (2) sets of four (4) digits. Examples for both types of Sale Counters are as follows:

SECTION 3. VENDER PROGRAMMING

Count Type	Actual Count	1st Display	2nd Display	3rd Display
Total Sale Count	5,678,910	"SALE"	"567"	"8910"
Selection Sale Count	678,910	"SL [number]"	"67"	"8910"

OPERATION: If **<enter>** is pressed when the display shows "SALE", the Control Board will enter the Sale Counter Mode. The display will flash "SALE" and the total amount of sales made by the Vender, possibly in two (2) sets of four (4) digits (see Example 1 above). Using **<up>** or **<down>** will cycle through individual selection sale counts. The display will flash individual selection counts (see Example 2 above). If **<home>** is pressed anytime during this operation, the Controller will return to the "SALE" display. From "SALE", pressing **<down>** will take you to "Error". Pressing **<up>** will take you to "rtn" (if present).



Return to Sales / Greeting Mode (rtn)

This mode is used to exit the External Menu and return to the Sales Mode where the display flashes the greeting (ICE COLD or PEPSI COLA) along with any other display options.

OPERATION: If **<enter>** is pressed when the display shows "rtn", the Controller will revert to the Sales Mode and the greeting will be displayed. From "rtn", pressing **<down>** will take you to "Sale". Pressing **<up>** will take you to "Error".



Errors Mode (Error)

This mode was designed to help diagnose Vender problems. Upon entering this mode, the display will flash any possible error (for a list, refer to Section 6, Vender Maintenance: Error Codes). If there are no errors, the display will momentarily flash "none" and revert to "Error" on the External Menu. Errors cannot be cleared from this External Errors Menu. They have to be cleared from the Internal Menu.

OPERATION: If **<enter>** is pressed when the display shows "Error", the Controller will enter into the Errors Descriptive Display Mode. At this point, the display will show any and all current Vender errors followed by the descriptions for each. If no errors exist, "none" will appear on the display. If **<home>** is pressed anytime during this operation, the Controller will return to the "Error" display. From "Error", pressing **<down>** will take you to "rtn".

CLEARING ERRORS: To clear an error, you must access the "Error" Mode from within the Password Protected Menus.

SECTION 4. VEND CYCLE

Vend Cycle

Stand-By Condition

In a Stand-By Condition, the Vender will show the greeting and possibly the vend price (if set for a single price or if all prices are set to same) and a choice of other optional features on the LED display. If a select button is pressed prior to reaching the vend price (establishing a credit), the display will show the vend price for that selection. This will indicate to the customer more money is needed for that particular selection.

Establishing Credit

As coins are inserted into the Coin Mechanism, a corresponding credit count will appear on the display. The Coin Mechanism will continue to accept coins until the highest vend price has been achieved. All coins in excess of the vend price will be returned to the coin cup. Once the vend price has been achieved, the Control Board will set up a credit enabling a vend to be made for any selection equal to or less than the established credit.

Valid Selection

The Vender's Control Board constantly sends a logic level signal to the common position of each select switch. When a selection is made, the selection switch closes. This allows the low voltage signal to travel from the switches common position through the switch and out the normally open position of that switch to the select switch's harness connection on the Control Board.

Vend Sequence

At this time (if there has not been a previous sold out), the Control Board distributes 24 volts DC through the door and cabinet wiring harnesses and directly to the coil of the chosen vend motor. Simultaneously the display will scroll. This is an indication to the customer a vend is in progress and to please wait. As the vend motor receives power, it will turn the rotor in an attempt to vend a can.

Product Delivery

As the can or bottle drops onto the product delivery chute, the vibration from the impact will allow the delivery sensor to send a low voltage signal to the Vender's Control Board. This indicates that a product has been vended. After the Control Board receives the sensor's signal, it will take into account how the Vender is programmed (set depth) and will act accordingly.

If the first can has just vended, the Control Board will kill all power to the vend motor at the exact same time that an impact is registered (this avoids a multiple vend of the next product to the rear of the cabinet). As the next can vends, the Control Board will cycle the vend motor to pick up another load of product. This allows a quick vend, less than three (3) seconds, for the next customer.

***Note:** The Control Board will go through a learning process known as the Learning Mode. It will be reset either on power down/up or a door opening/closing. This allows the Vender's Controller to decide which is the front or rear product. The Learning Mode acts in conjunction with the depth setting to allow for an automatic reload after the rear can has vended. How it works: The Controller will notice the first "long-timed out" vend cycle during the learning process. From this, the Controller will know the very next vend will be the front product.*

Sold-Out

Upon selection, the display will cycle to show the vend progress. After ten (10) to twelve (12) seconds (if a drop of product is not detected), the display will show "sold-out". A sold out may be due to:

1. The column attempted is jammed, therefore product does not drop,
2. The column attempted is genuinely sold out, or
3. The sensor is out of adjustment and does not detect the product drop.
4. If any or all selection, doesn't have a column assigned, it will read "Sold Out".

The digital display will indicate "sold out" and flash the sold out lamp. This signals to the customer to make another selection or push the coin return lever for a full refund. If set for forced purchase, the customer must make an initial selection. If the initial selection is sold out, the customer will be allowed a full refund or an alternate selection. If the Vender is totally sold out of a product, illumination of the "sold out" lamp and the "sold out" message on the digital display will be continuous. No money will be accepted into the Vender in a total sold out condition.

Resetting Sold Out Selections

A sold out condition is only cleared by the Vender's door switch by opening the Vender's main door. If a sold out condition is not cleared, the Controller will not attempt to vend from that selection. The display will not cycle to indicate a vend is in progress. It will automatically show "sold-out" upon pressing the select button (either before or after reaching a vend price).

SECTION 5: VENDER MAINTENANCE

Vender Maintenance

General Maintenance

WHAT TO CLEAN

A routine cleaning schedule is the best way to insure the optimum possible operation and appearance from your MERLIN IV Vender.

PART	CLEANING METHOD
Control Board*	The Vender's Control Board should always be enclosed inside its cover to protect it. Routine cleaning is not necessary but, if desired, the Controller's area may be blown out with compressed air.
Condenser and Evaporator Coils	For efficient operation, the Condenser and Evaporator Coils must be kept clear of any dirt or foreign materials. Clean dirt and lint from the Condenser and Evaporator Coils with a brush, vacuum cleaner, or compressed air.
Cabinet and Vend Mechanism	Steam clean as required. <i>Never</i> use petroleum cleaners or submerge electronics in water.

** Note: Never use petroleum cleaners or submerge electronics in water. If the Controller is accidentally sprayed with water, be sure to allow it to dry thoroughly before powering up the Vender.*

WHAT TO LUBRICATE

A routine cleaning schedule is the best way to insure the optimum possible operation and appearance from your MERLIN IV Vender.

PART	CLEANING METHOD
Latch Strike Nut	The Latch Strike Nut should be lubricated periodically with a petroleum base grease.
Inner Door Gasket	The door gasket comes from the factory pre-lubricated but should be lubricated periodically with a silicone base grease. Apply to the vertical piece of gasket on the hinged side of the inner door which touches the Vender's main door. This will help prevent any peel back of the gasket which can cause air leaks into the sealed cabinet resulting in freeze ups.
Refrigeration System	The Refrigeration System is a sealed unit and does not require any lubrication. Also, the Condenser and evaporator motors do not require any lubrication.

IMPORTANT SAFETY NOTE: *To prevent bodily injury or damaging the electronics, NEVER plug or unplug any electrical connectors with power applied.*

SECTION 5: VENDER MAINTENANCE

Using the Vender's Error Code System

The MERLIN IV Vender has a Built-in Error Code Diagnostic System that will help you troubleshoot and solve problems. This system is best used in conjunction with the Troubleshooting Section in the rear of this Manual. The error codes shown below consist of two codes: a Main Error and a Detailed Error. These errors are not a replacement for your knowledge of the Vender or its operation. They will only point you in the general direction of the problem. Most Vender parts are independent of one another. Because of this, most problems can be confined to the item in question (such as a LED Display, Coin Changer, or Select Switch), the harnessing connecting it to the Control Board, and the Control Board itself. Upon opening the Vender's main door, you will enter the Service Mode. The display will flash any Vender Error Codes or "none" if no problems exist. Errors can be cleared from the "Error" Mode within the Service Menu.

Note: It is recommended the Error Codes be cleared after correcting any problem(s) to prevent confusion and unnecessary work in the future.

Error Codes

MAIN	DETAILED ERROR	CORRECTIVE ACTION
SELS	SS 1 thru SS 12 (sel. switch closed)	Fix stuck button/switch or replace switch
CHAr	CC (Changer Communication)	Check changer harness connections
	TS (Changer Tube Sensor)	Consult changer manufacturer
	IC (Inlet Chute Blocked)	Check Vender's coin chute for blockage
	tJ (Changer Tube Jam)	Check changer's coin tubes/tube sensors
ACCE	CrCh (Changer ROM Checksum)	Consult changer manufacturer
	EE (Excessive Escrow)	Check for stuck coin return lever
	nJ (Acceptor Coin Jam)	Check for blockage/dirty sensor in acceptor
	LA (Low Acceptance Rate)	Consult changer manufacturer
Chut	CS (Chute Sensor Always On)	Adjust Chute Sensor (refer to Section 3)
StS	DAxx (Double Assigned Column)	Correct space to sales setting if necessary
	UAxx (Unassigned Column)	Correct space to sales setting if necessary
bUAL	bS (Bill Validator Sensor)	Remove obstruction or clean sensors
	biLL (Bill Validator Motor)	Consult bill validator manufacturer
	BJ (Bill Jam)	Remove jammed bill or clean bill sensors
	bOPn (Bill Validator Cash Box Open)	Close bill acceptor cash box
	bFUL (Bill Validator Cash Box Full)	Remove bills from cash box
FriG	bC (Bill Validator Communications)	Check bill validator harness connections
	SEnS (Temperature Sensor)	Check for a cut/disconnected temperature sensor
	CoLd (Sensing Temperature 3 Degrees below Cutout)	Check for a welded contact in refrigeration relay or shorted wire from board to Refrigeration Relay
	CnPr (Not Cooling Within 30 Minutes Of Cut in)	Check "FrG" in programming and check all wiring connections from board to refrigeration unit
	ACLo (Less Than 95 Volts For Greater Than 30 Minutes)	Check voltage at wall outlet during the peak of the load with all units (if any others are present in circuit) running.

SECTION 5: VENDER MAINTENANCE

Merlin IV

Troubleshooting

Use the following section to troubleshoot your MERLIN IV vender in the case you have a problem in one of the following areas: power, acceptance (coin or bill), vending, or refrigeration. Although we have added what we felt are the most encountered problems, your specific problem may not be here. If this is the case please, contact your local Royal Vendors' service representative.

COIN ACCEPTANCE

TROUBLE	POSSIBLE CAUSE	CORRECTIVE PROCEDURE
Coin mechanism will not accept coins	No power to Vender's main door (lights not lit) or no power to transformer / Control Board	Check to make sure the LED and the sign lighting are lit. If not, check power at transformer.
	Coin mechanism harness to Control Board is cut or disconnected	Repair or replace changer harness.
	Short in coin mechanism	Unplug all harnessing from the Control Board except the transformer (power) connection, and the coin mechanism connection and test acceptance. If it accepts, replug each connection, one at a time, and test acceptance after each.
No acceptance or rejects percentage of good coins	Defective Control Board	After a new coin mechanism has been tried and the harness has been checked for continuity, replace Control Board.
	Coin return lever	Make sure changer is mounted correctly and the coin return lever is in the proper position.
	Acceptor is dirty or foreign matter is in the path	Check to ensure that the coin mechanism's acceptor is clean.
	Coin changer is improperly tuned (if tunable)	Contact coin changer manufacturer.
Accepts coins but gives erratic/no credit	Defective Control Board	Replace the Control Board and test.
	<i>If erratic or no credit:</i> Acceptor (coin mechanism)	Replace coin mechanism (acceptor) and test. If OK, check the following.
	If no credit, defective harness between coin mechanism and Control Board	Check harness for cut wires or wrong connections. If defective, replace it.
	If no credit, defective Controller	Replace Control Board and test.

SECTION 5: VENDER MAINTENANCE

TROUBLE	POSSIBLE CAUSE	CORRECTIVE PROCEDURE
Changer will not payout coins	Defective harness between coin mechanism and Control Board	Check harness for cuts or wrong connections. If defective, replace it.
	Defective coin mechanism	Replace coin mechanism and test. If it pays out test the Control Board.
	Defective Controller	Test Vender's manual coin payout. If Vender pays out using the CPO mode but not during sales, check the coin mechanism or coin mechanism harness. The Control Board is more than likely not the problem.

BILL ACCEPTANCE

Validator will not pull in a bill	Make sure that the validator harnessing is correct for your style of validator and it is plugged in properly	Replace defective or wrong validator harness.
	Acceptance disabled by coin mechanism or bad harnessing (validator status light is on)	Make sure that the coin mechanism is plugged in (accepts coins) and the tubes are full of coins.
	Make sure that the changer harnessing is correctly connected	Repair or replace faulty harnessing.
	If validator accepts, replace coin mechanism and test.	Replace defective validator.
	If validator accepts, replace validator and test	Replace defective validator.
Validator takes a bill and not establishing a credit	If validator accepts, replace Controller and test	Replace defective Controller.
	Defective (wrong, cut or miswired) validator harnessing. (credit not getting from validator to Control Board via credit wire)	Make sure that the validator harnessing is correct for your style of validator and it is plugged in / wired properly.
	Defective validator	Replace validator and test acceptance.
Validator takes a bill and not erasing credit	Defective Controller	Replace Controller and test acceptance.
	Validator switch settings (if any)	Refer to validator service manual or validator representative.
	Defective validator interface harness	Refer to validator service manual or validator representative
Validator takes a bill and not erasing credit	Defective validator	Replace validator and test acceptance and erasure of credit.
	Defective Controller	Replace Controller and test acceptance and erasure of credit

SECTION 5: VENDER MAINTENANCE

TROUBLE	POSSIBLE CAUSE	CORRECTIVE PROCEDURE
Validator takes a bill and allows payback of coins without a selection	Controller's configurations not set properly	Access the Venders Configurations Mode and check the "Forced Attempt" setting.

VENDING PROBLEMS

Multiple vending	If from all selections: delivery sensor cut, not properly grounded, disconnected, or improperly set	Set Venders delivery sensor by turning the adjustment screw: 1. clockwise until indicator lights 2. counter clockwise until it goes out 3. counter clockwise 1 full turn If no progress is made by adjusting, replace sensor. <i>Note: Slight adjustments may be needed outside the factory set one turn. Turning the adjustment screw clockwise makes the sensor more sensitive and counter clockwise makes it less sensitive. Test vend after every 1/4 turn.</i>
	Control Board sending power to motor when not supposed to	Check power at vend motor during multiple vend (24 volts DC). If power is present, the Control Board is at fault.
	Mechanical error gearing within it is OK.	Check the vend motor to ensure the
Wrong product vending upon selection	Misload by Vender loader	Ensure all products within each column are the same.
	Space to Sales not set properly	Enter Space to Sales and make sure the columns are set correctly according to the buttons.
	Miswired motor	Check wiring at the each vend motor at the bottom of the Vender's main door and at the motor's connection of the Control Board.
	Miswired selection	Check the wiring at each select switch and at the select switch's connection of the Control Board.
No vend upon selection - Dry vend (no refund)	Delivery sensor	Check to see if the delivery sensor adjustment LED is constantly on. If so, turn the adjustment screw counter clockwise until adjustment LED goes out.
	Check delivery sensor harness for cuts or pinches. The sensor adjustment LED will constantly be on, if a cut is found.	Replace defective sensor.

SECTION 5: VENDER MAINTENANCE

TROUBLE	POSSIBLE CAUSE	CORRECTIVE PROCEDURE
	Unplug the sensors connection from the Control Board, if the adjustment LED stays on	Replace defective controller.
No vend from some but not all columns (allows refund or second choice)	Make sure the LED display acknowledges the selection switch.	Check the select switch and trace the selections harness back to the Control Board. Replace if necessary.
	Individual wire that runs from the motor connection of the Control Board to the vend motor of the defective column.	If cut or pinched, check individual wire running from motor connection at Control Board to defective column.
	Control Board	Measure voltage at vend motor's connection of the Control Board. Measure it on the individual wire for the motor attempted and the wire by itself next to the key (neutral). A selection must be made and "hold" must be displayed on the LED. You should register 24 VDC at the vend motor. If not, replace Control Board.

MISCELLANEOUS PROBLEMS

LED not lit	If no power, check for 24 volts AC at the Control Board's power connection.	Check transformer and power to transformer.
	Press Controller's mode button. Does LED light? Power the Vender down and up. Does LED light?	If not, check LED lead.
	LED lead	Check the lead for any sign of being pinched or cut. If so, change the LED.
	LED	Remove all harnessing but LED lead and the power lead from transformer to Control Board. Check the new LED before mounting it in the Vender. If still bad, replace the Control Board and test.

SECTION 5: VENDER MAINTENANCE

TROUBLE	POSSIBLE CAUSE	CORRECTIVE PROCEDURE
Display shows sold out immediately upon pressing select button with column full of product (sold-out not clearing)	Door switch wiring incorrectly connected, cut, or pinched	Check for cuts on the two (2) door switch wires going from the switch to the Control Board. Also check for bad connections at the door switch, the plug at the bottom of the Vender's main door, and at the Board's connection. Are any found? If not, check the door switch.
	Door switch	Check the door switch to see if it is defective. If so, replace it.
	Control Board	Check Control Board by shorting across the two (2) pins for the door switch wiring (Control Board's option connection) Does this clear the sold out condition? If so, replace the Control Board.

REFRIGERATION PROBLEMS

Refrigeration unit runs constantly	Cut out temperature not set properly	Check cut out setting in the "FriG" mode. Correct if necessary.
	Temperature sensor not reading correctly	Test the temperature sensor by showing the temperature on the display and measuring the actual inside cabinet temperature with a thermometer or by opening/closing door to see if the temperature changes. Replace if defective.
	Short in wiring harness from Controller to refrigeration relay	Unplug one (1) of the two (2) wires coming from the Control Board to power the relay. If the unit cuts off, locate the shorted wire to be either on the door side or the cabinet side of the harness and correct or replace defective harness.
Refrigeration relay's contacts are welded together	Unplug one (1) of the two (2) "pink" connector wires coming from the Control Board to power the relay. If the unit continues to run, switch the two (2) "blue connector" wires coming from the main wiring harness to the two (2) other available connectors (if present). If not, replace relay.	

SECTION 5: VENDER MAINTENANCE

TROUBLE	POSSIBLE CAUSE	CORRECTIVE PROCEDURE
Refrigeration unit will run	Unit itself is defective	Unplug the refrigeration unit from the top of not the main wiring harness and plug it into a direct power source. If it does not run, replace the refrigeration unit.
	“FrG” setting not set properly	Check “FrG” setting in the “FriG” Mode to make sure it is set to “1”. If set incorrectly, reprogram it to show “1”
	Cut in / Cut out settings not set properly	Check cut in /cut out settings. If set incorrectly, reprogram them.
	Temperature sensor not reading correctly	Test the temperature sensor by showing the temperature on the display and measuring the actual inside cabinet temperature with a thermometer or by opening/closing door to see if the temperature changes. If found defective, replace temperature sensor.
	Short in wiring harness from Controller to refrigeration relay	Unplug the two (2) “pink” connector wires coming from the Control Board and measure voltage. You should read approximately 24 volts DC from one (1) of the wires. If not, locate the shorted wire to be either on the door side or the cabinet side of the harness and correct or replace defective harness.
	Refrigeration relay is defective	Test the relay by making sure all connections are made for the refrigeration unit, the refrigeration relay and the Control Board. Next go into the “FriG” mode. Check the Compressor by pressing <enter> when you get to “CnPr” and pressing <enter> again when the display flashes “CnPr” and “On”. If the unit does not come on, switch the two (2) wires coming from the main wiring harness to the two (2) other available connectors (if present). If not, replace relay.

SECTION 6: EXPLODED VIEWS AND PART NUMBERS

Control Board and Wiring

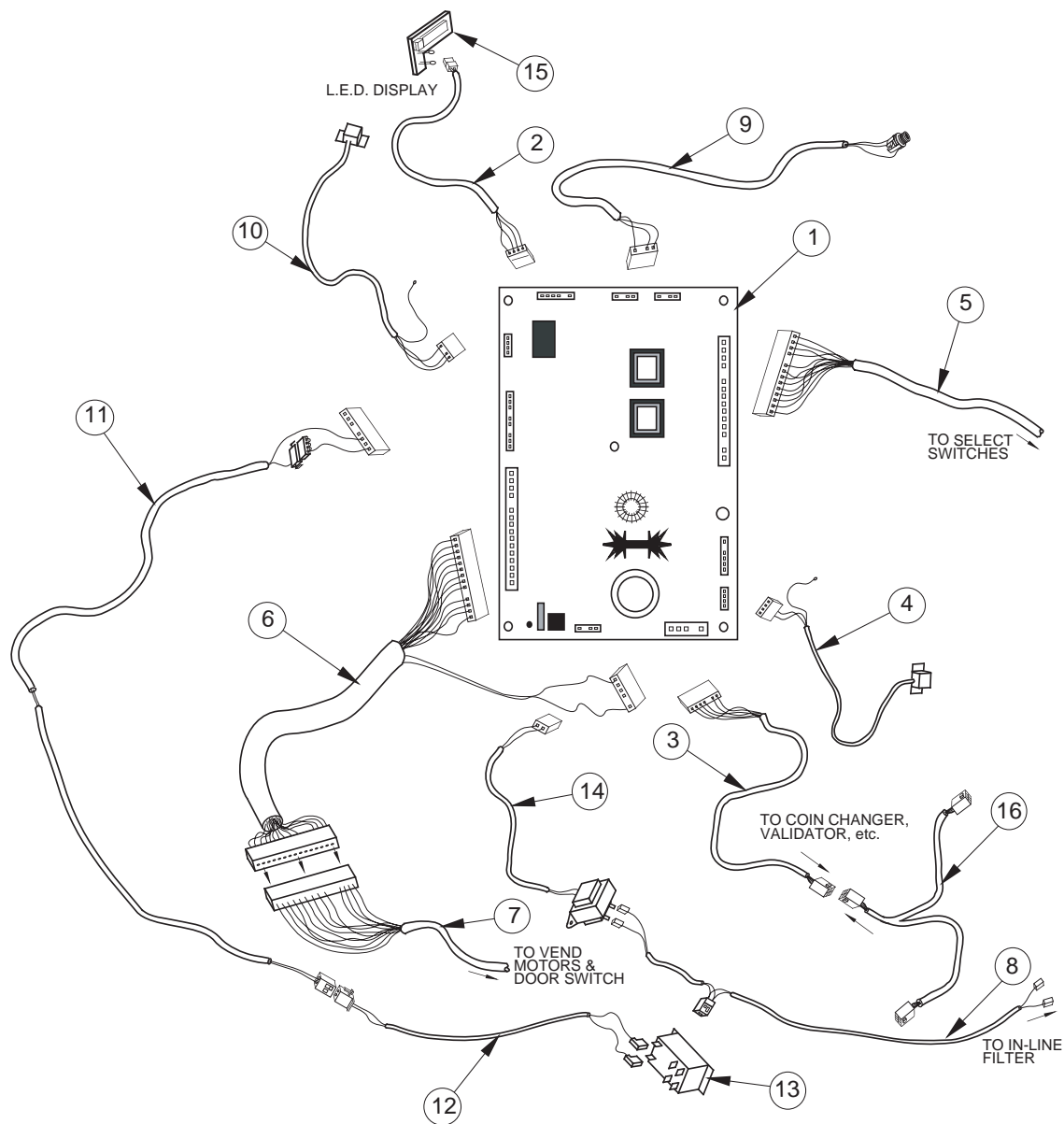

exploded
views

I.D. #A235,083,003RV

SECTION 6: EXPLODED VIEWS AND PART NUMBERS

Control Board and Wiring

ITEM #	DESCRIPTION	PART NUMBER
1	Control Board	836101
2	LED Display Lead	842081
3	Serial Changer Harness	842079
4	Delivery Sensor (includes harness)	836004
5	Select Switch Harness, Pepsi Cola 10 Select	842190
	Select Switch Harness, Live Display Vender	842192
6	Main Door Harness (vend motor/door switch wiring)	842169
7	Cabinet Harness, 12 Column Mechanism (Wide)	842174
	Cabinet Harness, 10 Column Mechanism (Narrow)	842231
	-1521 and after (Wide)	842230
	-1521 and after (Narrow)	842231
8	Merlin IV Harness Assy. 117V Line	842151
9	Internal HH. Phone Jack and Harness	842099
10	Temperature Sensor (includes harness)	822030
11	Refrigeration Relay Harness, Door Side	842236
12	Refrigeration Relay Harness, Cabinet Side	842237
13	Relay (to control refrigeration system)	836065
14	Transformer Assembly	842147
	Merlin IV Harness, Transformer and Fuse to Board	842210
	Fusebox Assembly	842219
15	LED Display	836012
16	MDB Harness	842116

SECTION 6: EXPLODED VIEWS AND PART NUMBERS

Port Assembly

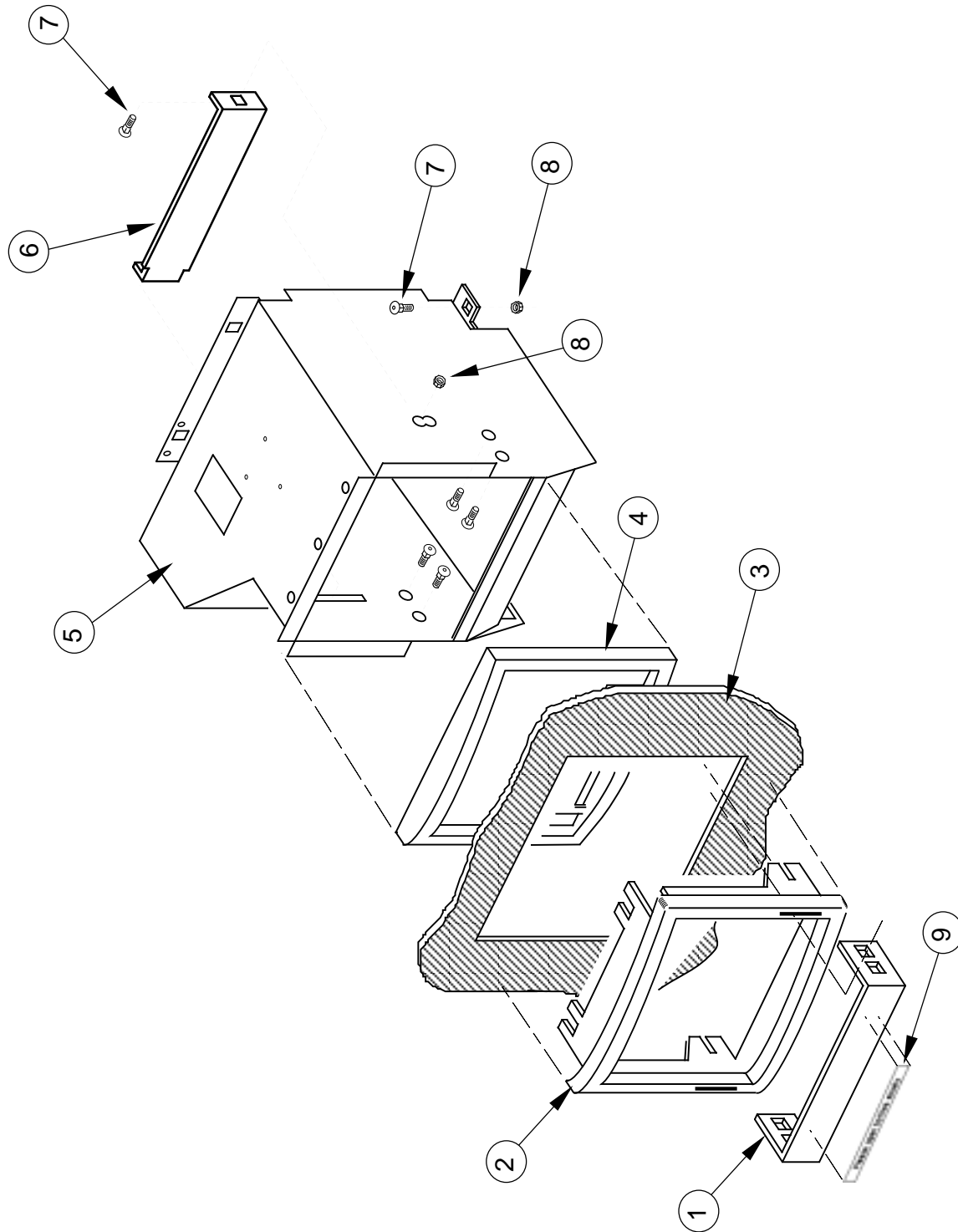

I.D. #A235,069,003RV

SECTION 6: EXPLODED VIEWS AND PART NUMBERS

Port Assembly

ITEM #	DESCRIPTION	PART NUMBER
1	Can Stop	010508
	Can Stop (Wide Port)	273508
2	Port Trim	815019
	Port Trim (Wide Port)	815249
3	Sign	SEE NOTE #1
4	Port Spacer	815020
	Port Spacer (Wide Port)	815248
5	Port Body W/A, Merlin IV Narrow Venders	261510
	Wide Port Assembly	273510
6	Anti Theft Plate, Non CDC Wide	263505
	-CDC Wide	273507
7	Bolt 1/4-20	901007
8	Nut 1/4-20	905002
9	Anti-Foaming Label	931355
•	Enclosed Coin Cup Kit (wide)	303150

NOTE #1: There are various parts. Please specify model and serial number at the time of order.

SECTION 6: EXPLODED VIEWS AND PART NUMBERS

Inner Door Assembly

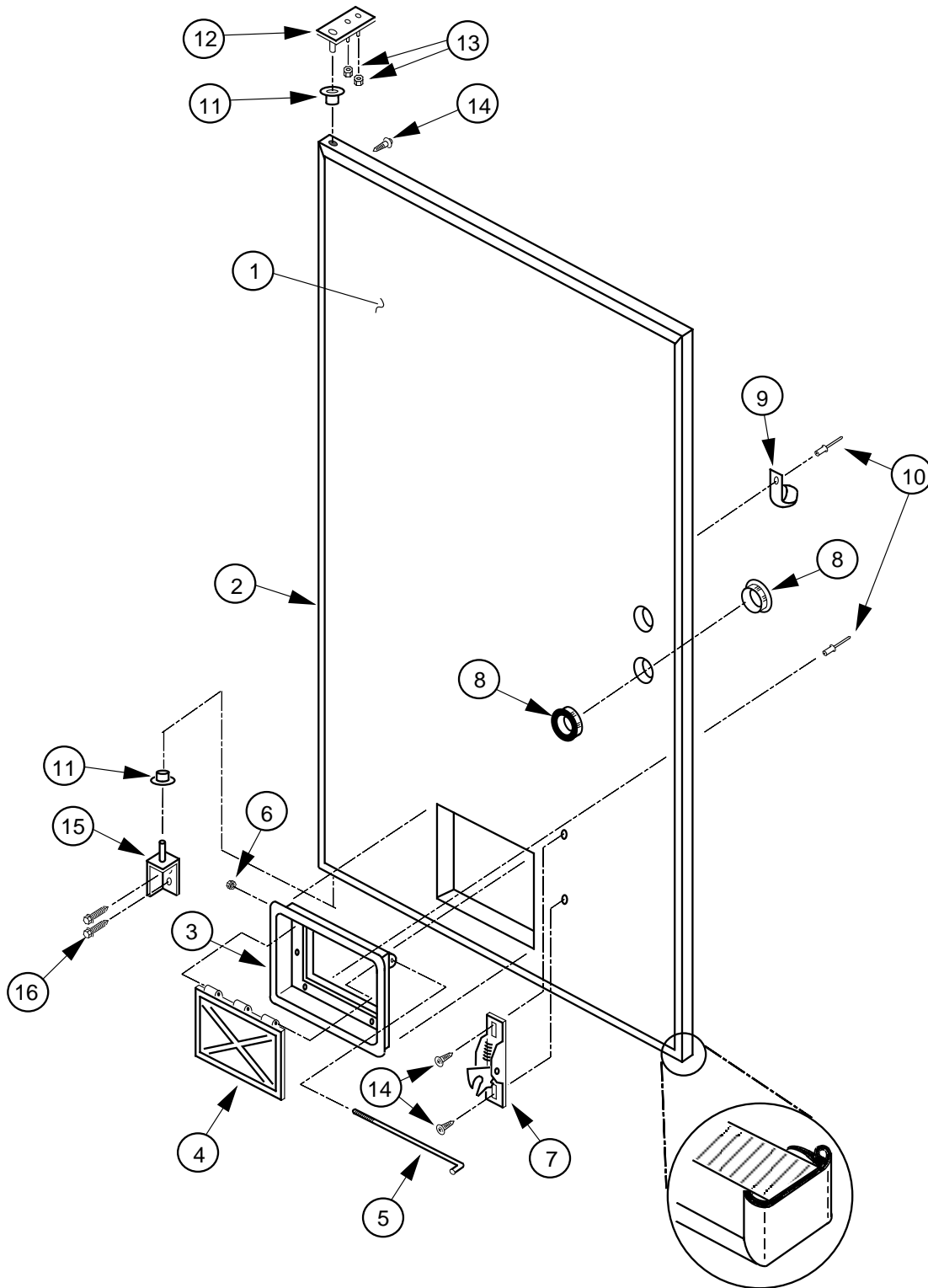

I.D.# A235,043,003RV

SECTION 6: EXPLODED VIEWS AND PART NUMBERS

Inner Door Assembly

ITEM #	DESCRIPTION	PART NUMBER
1	Inner Door Assembly 79" Wide Venders	261640
	Inner Door Assembly 79" Narrow Venders	258630
	Inner Door Assembly 79" Dr Pepper Vision 4	271640
	Inner Door Assembly 72" Wide Venders	262660
	Inner Door Assembly 72" Narrow Venders	264630
	Inner Door Assembly 72" Dr Pepper Vision 4	272640
2	Inner Door Gasket 79" Wide Venders	815033
	Inner Door Gasket 79" Narrow Venders	815218
	Inner Door Gasket 72" Wide Venders	815032
	Inner Door Gasket 72" Narrow Venders	815219
3	Port Door Frame	815191
4	Port Door	815192
5	Port Door Rod	811028
6	Elastic Stop Nut	905006
7	Burst Open Latch	812002
8	Bushing, 1.37"	916003
9	Cable Clamp	916004
10	1/8" Rivet	908002
11	Inner Door Bushing	815026
12	Inner Door Hinge (Top)	010520
13	Nut, 8-32	905001
14	Self Drilling Screw W/ Washer	902001
15	Inner Door Hinge, Bottom	010550
16	Self Tapping 1/4 - 20 X 1"	901003
•	Space to Sales Decal M-IV (10 column vender)	931301
•	Space to Sales Decal M-IV (12 column vender)	931302

SECTION 6: EXPLODED VIEWS AND PART NUMBERS

Main Door Hinge, Lifter & T-Handle Assemblies

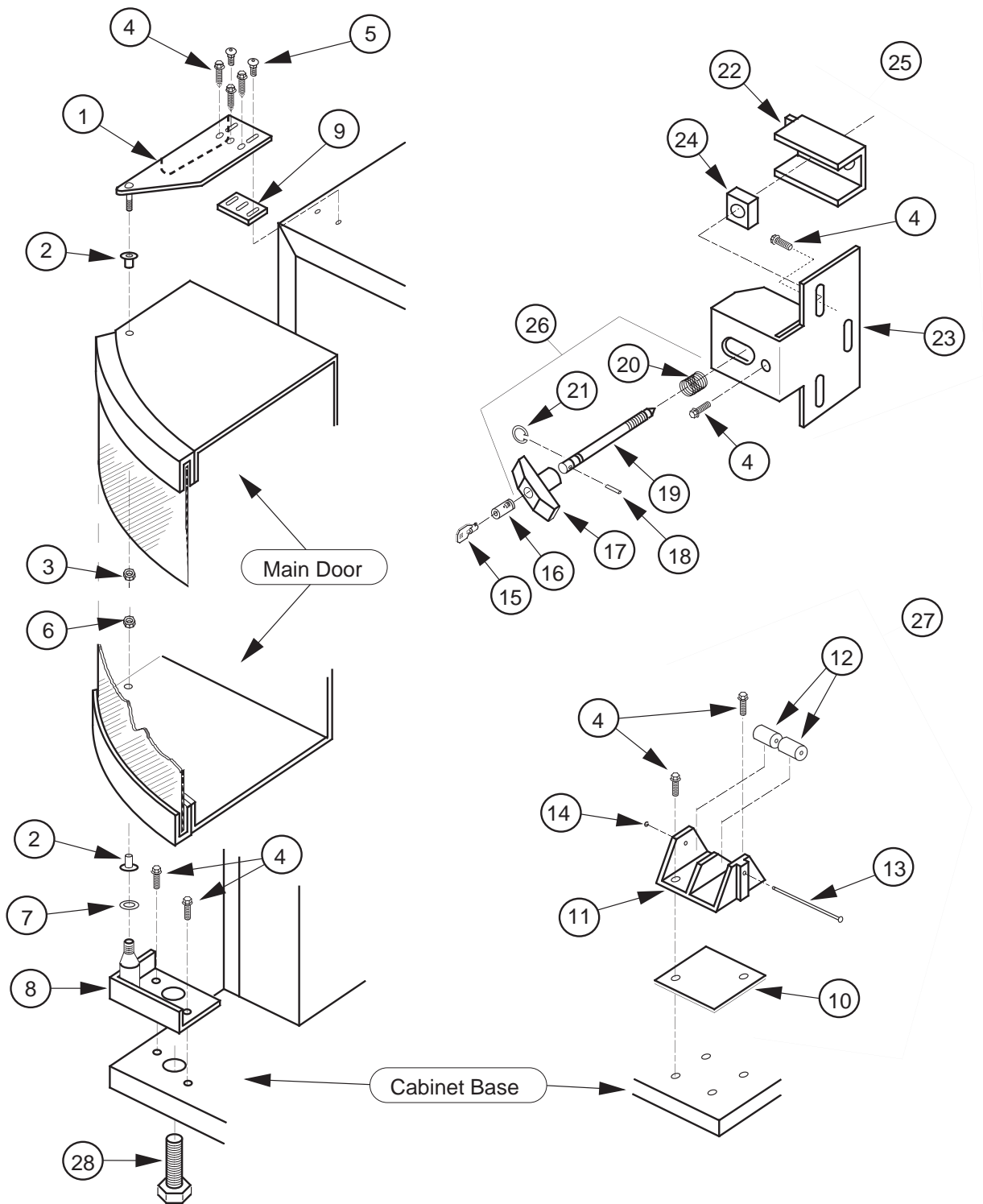

I.D.# A235,044,003RV

SECTION 6: EXPLODED VIEWS AND PART NUMBERS

Main Door Hinge, Lifter & T-Handle Assemblies

ITEM #	DESCRIPTION	PART NUMBER
1	Universal Hinge	164550
	-Top Hinge	810002
2	Bearing Nyliner	916012
3	5/8" Keps Nut	905016
4	Self Tapping 1/4 - 20 X 1"	901003
5	Carriage Bolt 1/4 - 20 X 1 1/4"	901008
6	Keps Nut 1/4 - 20	905002
7	Flat Washer	904002
8	Bottom Hinge Bracket W/A	010040
9	Top Hinge Spacer	010016
10	Door Roller Spacer	010015
11	Door Roller Bracket	SEE NOTE #2
12	Door Roller	SEE NOTE #2
13	Door Roller Pin	SEE NOTE #2
14	Retainer Ring 5/32"	906005
15	Key	SEE NOTE #1
16	Lock	SEE NOTE #1
17	T-Handle Body	SEE NOTE #2
18	Pin	SEE NOTE #2
19	"T" Handle Stud	SEE NOTE #2
20	Spring	SEE NOTE #2
21	Retainer Ring	SEE NOTE #2
22	Nut Retainer	010028
23	Latch Strike, Merlin IV	010027
24	Square Nut 3/4 X 1/2 - 13	905005
25	Latch Strike Assembly, Merlin IV	010030
26	T-Handle Assembly (shown)	812001
	"Flush Mount" T-Handle Assy used w/ CDC (Prior to 1521)	812176
	-1521 and after	812289
27	Door Roller Assembly	141180
28	Leveling Leg	803002

NOTE #1: There are various parts. Please specify model and serial number at the time of order.

NOTE #2: This part is not available individually. It must be ordered as an assembly.

SECTION 6: EXPLODED VIEWS AND PART NUMBERS

Refrigeration System Assembly

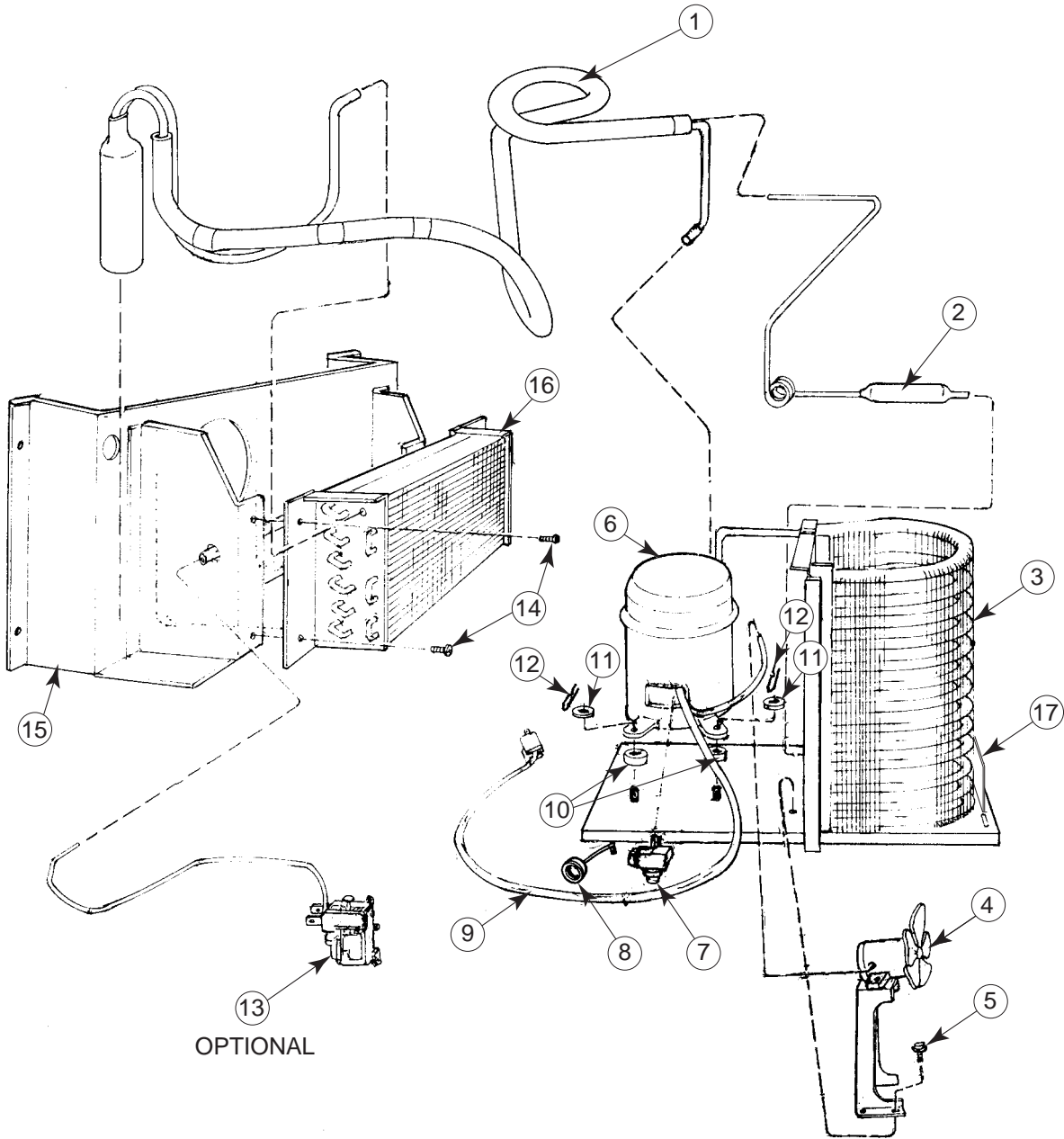

I.D.# A235,045,003RV

SECTION 6: EXPLODED VIEWS AND PART NUMBERS

Refrigeration System Assembly

ITEM #	DESCRIPTION	PART NUMBER
1	Heat Exchange	210425
2	Dryer	824005
3	Condenser	820007
4	Condenser Fan Motor Assembly (w/Blade)	839010
	Condenser Fan blade	810014
5	Screw, #8-32x1/2"	901006
6	1/3+ H.P. Capacitor Start Compressor	819028
7	Compressor Relay 1/3+ H.P. (Tecumseh Only)	822042
8	Compressor Overload 1/3+ H.P. (Tecumseh Only)	822010
9	Compressor Lead	See note #2
10	Grommets, Compressor	916015
11	Grommets Plugs	815017
12	Clip, Compressor	914002
13	Thermostat	822001
14	Screw, #8x1/2"	902004
15	Evaporator Fan Shroud Assembly, Wide	256080
	Evaporator Fan Shroud Assembly, Narrow	258070
16	Evaporator Coil	820002
17	Refrigeration System, Merlin IV 1/3+ H.P.	256420
•	Evaporator Cover	256004

Note #2: This part is not available individually. It must be ordered as an assembly.

SECTION 6: EXPLODED VIEWS AND PART NUMBERS

Evaporator Fan Motor Assembly

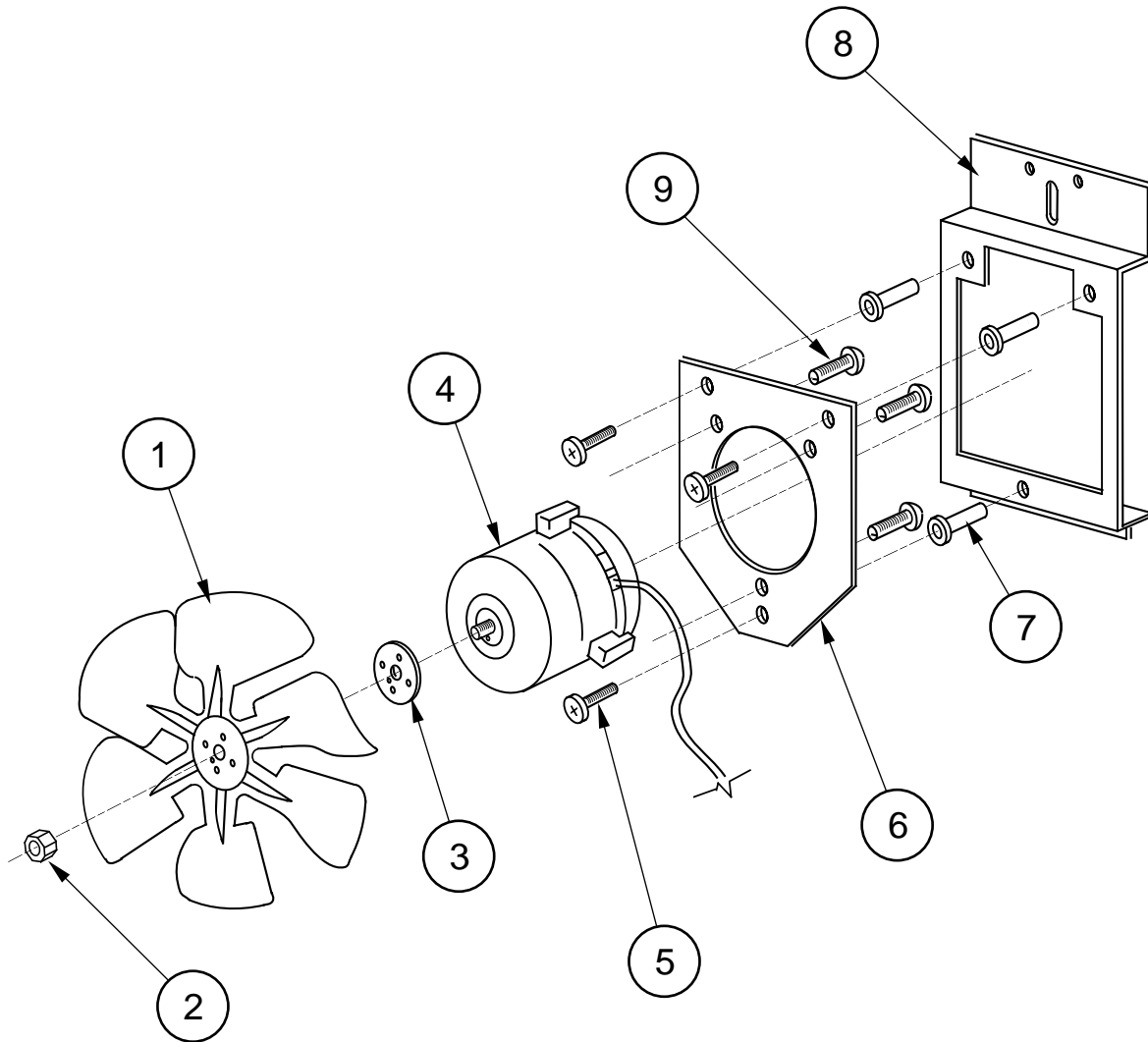

I.D.# A235,006,003RV

SECTION 6: EXPLODED VIEWS AND PART NUMBERS

Evaporator Fan Motor Assembly

ITEM #	DESCRIPTION	PART NUMBER
1	Fan Blade	n/a
2	Nut 1/4-20	905002
3	Silencer	N/A
4	Motor, 35w. / 115v.	n/a
5	Machine Screw #8-32x1/2"	901038
6	Fan Plate	010058
7	Well Nut	905026
8	Fan Mounting Bracket	010057
9	Screw #8-32x3/8"	901011
•	Evaporator Fan Motor Assembly, 35 w (all items)	303121

SECTION 6: EXPLODED VIEWS AND PART NUMBERS

Vend Mechanism Assembly

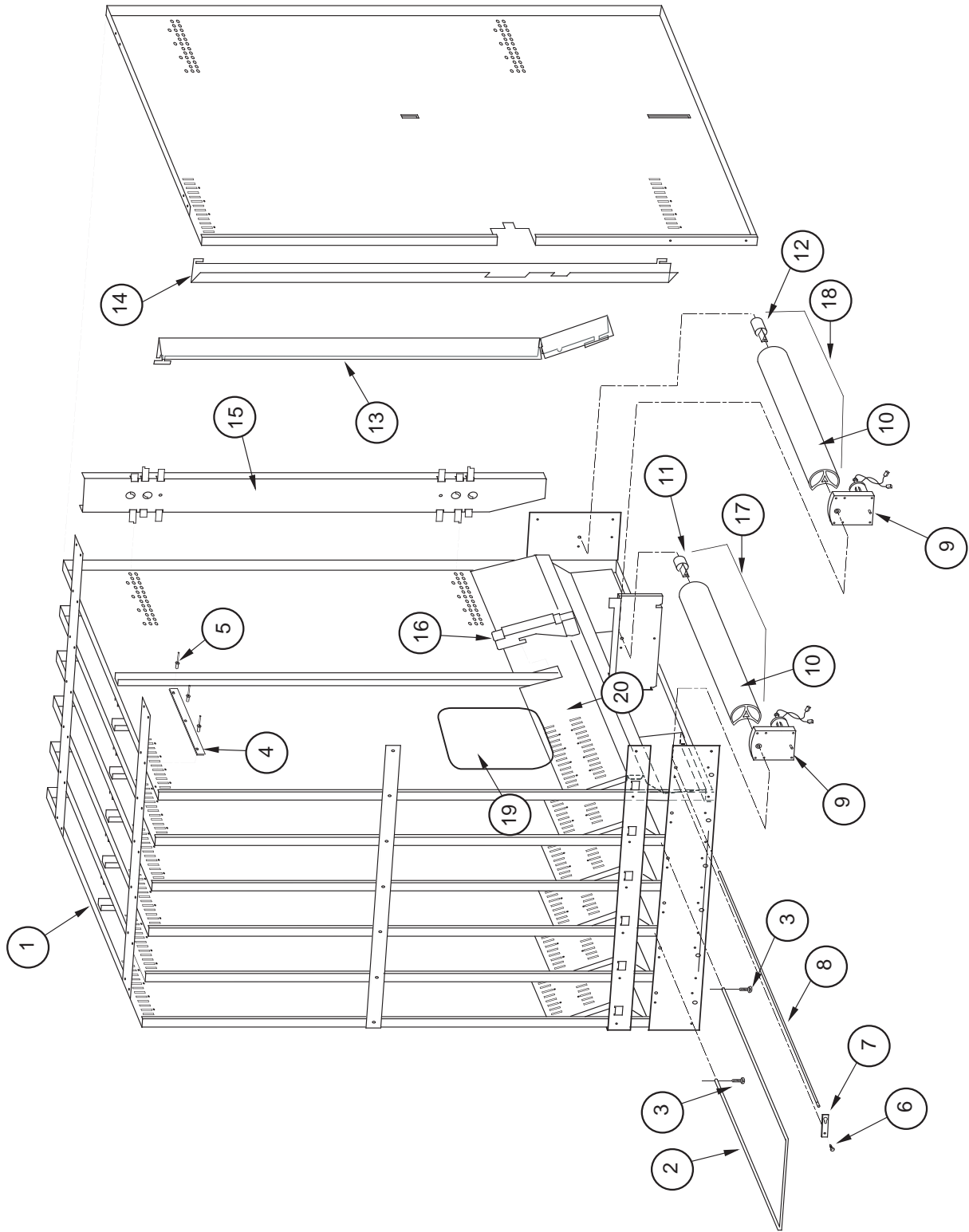

I.D.# A235,046,003RV

SECTION 6: EXPLODED VIEWS AND PART NUMBERS

Vend Mechanism Assembly

ITEM #	DESCRIPTION	PART NUMBER
1	Vend Mechanism Assembly, 12 Col. 79" Vender	256710
	Vend Mechanism Assembly, 12 Col. 72" Vender	262720
	Vend Mechanism Assembly, 10 Col. 79" Vender	258710
	Vend Mechanism Assembly, 10 Col. 72" Vender	264710
2	Case Support, Wide	811026
	Case Support, Narrow	811033
3	Self Drilling Screw	902004
	Hitch Pin Clip (<i>some venders may have pins</i>)	906023
4	Rubber Strip	915199
5	1/8" Rivet	908002
6	Screw, #8-32x3/8"	901011
7	Rod Retainer	256714
8	Rotor Rod	803035
9	Vend Motor, Merlin IV	839031
	-1618 and Before	839029
10	Rotor, Merlin IV	815305
11	Front Rotor Bearing	915156
12	Rear Rotor Bearing	915222
13	Product Retainer, Left (79" Vender)	256716
	Product Retainer, Left (72" Vender)	257706
14	Product Retainer, Right (79" Vender)	256715
	Product Retainer, Right (72" Vender)	257705
15	Backspacer Assembly (79" Vender)	256730
	Backspacer Assembly (72" Vender)	257730
16	Funnel Angle	256719
17	Rotor Assembly, Front Column	256740
18	Rotor Assembly, Rear Column	256750
19	Anti-friction Sheet	915197
20	Can Funnel	256712

SECTION 6: EXPLODED VIEWS AND PART NUMBERS

Miscellaneous Assemblies

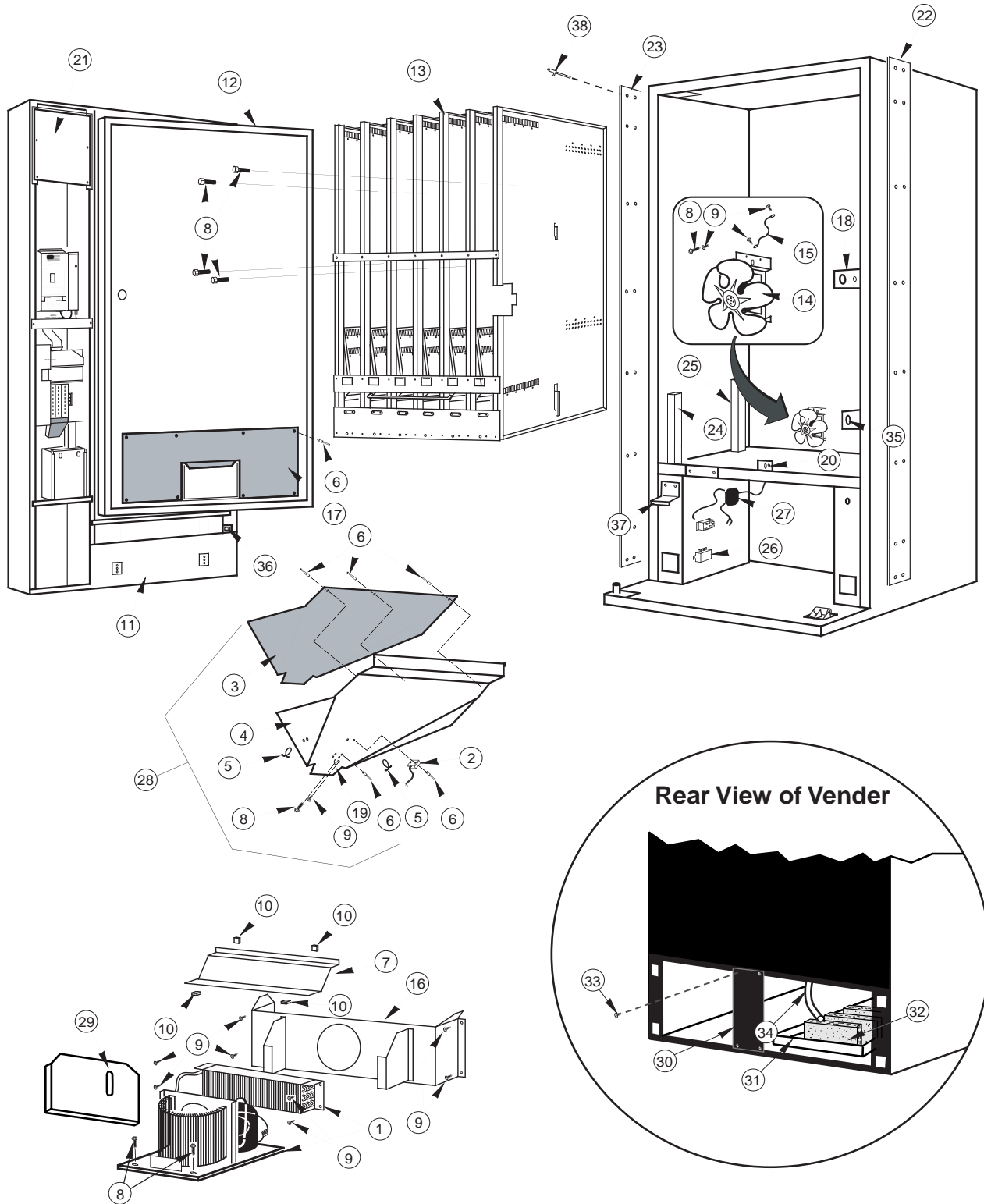

I.D.# A235,047,003RV

SECTION 6: EXPLODED VIEWS AND PART NUMBERS

Miscellaneous Assemblies

ITEM #	DESCRIPTION	PART NUMBER
1	Refrigeration System	256420
2	Delivery Chute Sensor	836004
3	Delivery Chute Liner, Wide Vender	815262
	Delivery Chute Liner, Narrow Vender	815270
4	Delivery Chute, Wide Vender	256005
	Delivery Chute, Narrow Vender	258001
5	Tension Clips	916059
6	Rivets, 1/8"	908004
7	Evaporator Cover	256004
8	Self Tapping Screw, 1/4-20x1"	901003
9	Self Drilling Screw, #8x1/2"	902004
10	"U" Clips	906007
11	Pepsi Door Weld Assembly, 10 Sel. 79" Wide Vender	227510
	Pepsi Door Weld Assembly, 8 Sel. 79" Narr. Vender	263510
	Cold Drink Door Weld Assembly, 10 Sel. 79" W.V.	216510
	Cold Drink Door Weld Assembly, 8 Sel. 79" N.V.	268510
12	Inner Door Assembly 79" Wide Vender	271640
	Inner Door Assembly 79" Narrow Vender	258630
	Inner Door Assembly 72" Wide Vender (Dr Pepper Vision IV)	272640
	Inner Door Assembly 72" Narrow Vender	264630
13	Vend Mechanism Assembly, 12 Column 79" Vender	256710
	Vend Mechanism Assembly, 12 Column 72" Vender	262720
	Vend Mechanism Assembly, 10 Column 79" Vender	258710
	Vend Mechanism Assembly, 10 Column 72" Vender	264710
14	Evaporator Fan Motor Assembly	210400
15	Grounding Wire	Misc.
16	Evaporator Fan Housing, Wide Vender	256080
	Evaporator Fan Housing, Narrow Vender	258070
17	Inner Door Cover Assembly, Wide Vender	815259
18	Latch Strike Assembly	010030
19	Bracket, Chute Locator	141014
20	Can Chute Tie Bracket	010017
21	PC Board Cover	141903
22	Right Cabinet Vandal Panel 79" (specify color)	012122
	Right Cabinet Vandal Panel 72" (specify color)	011002
23	Left Cabinet Vandal Panel 79" (specify color)	010022
	Left Cabinet Vandal Panel 72" (specify color)	011001
24	Mech. Support, W/A	256013
25	Mech. Support, 3 Deep	058001
26	In-Line Filter Assembly	011124
27	Main Wiring Harness	842063
28	Can Chute Assembly, Wide Vender	256070
	Can Chute Assembly, Narrow Vender	258001
29	Condenser Baffle	010403
	Condenser Baffle (Narrow M-IV)	258401
30	Rear Baffle	010037
31	Condensate Pan	815368
32	Sponge	815037
33	Self Drilling Screw	902004
34	Drain Tube	815134
35	Door Switch (Before P.O. 1521)	835003
36	Door Switch (1521 and after)	835019
37	Door Switch Actuator	231009
38	Pop Rivet	908018
•	Caster Kit Assembly, Heavy Duty M-IV	256130
•	Mesh Cabinet Back (Wide)	141001
	-Narrow	258004
•	Steel Cabinet Back (Wide)	010215
	-Steel Narrow	258005
•	Drain Hose Clip	906025

SECTION 6: EXPLODED VIEWS AND PART NUMBERS

Door Assembly, Front

Cold Drink 1533 & before

W/A 10 Sel. 79" W 216510
 -8 Sel N 268510

Left Side Trim 79" W 032505
 -72" 019507

Top Trim W 032504
 -Narrow 044513

Bottom Trim Wide 032504
 -Narrow 044514

Right Side Trim 79" Wide ... 032506
 -72" 019508

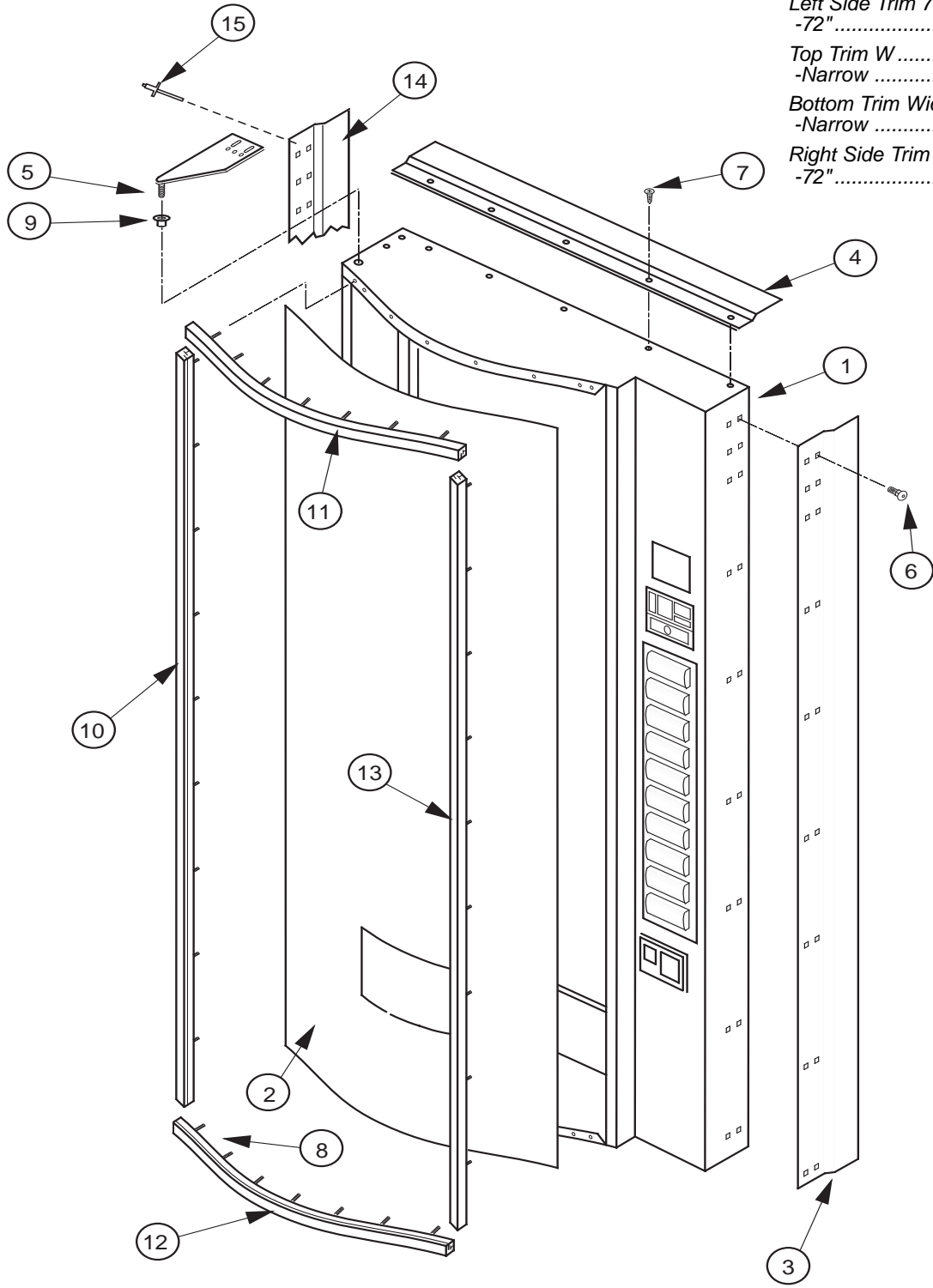

I.D.# A235,048,003RV

SECTION 6: EXPLODED VIEWS AND PART NUMBERS

Door Assembly, Front

ITEM #	DESCRIPTION	PART NUMBER
1	Pepsi Door Weld Assembly, 10 Sel. 79" Wide Vender	227570
	Pepsi Door Weld Assembly, 8 Sel. 79" Narrow Vender	263580
2	Sign	SEE NOTE #1
3	Right Vandal Panel 79" (Specify color)	010519
	Right Vandal Panel 72" (Specify color)	011501
4	Rain Guard, Wide Venders	258504
5	Top Door Hinge	810002
6	Carriage Bolt, 1/4-20x1/2"	901007
7	Self Drilling Screw, #8x1/2"	902004
8	"T"-Screw 8-32	901001
9	Top Door Bushing	803003
10	Left Side Trim 79" Wide Vender	142502
	Left Side Trim 72" Wide Vender	019507
	Left Side Trim 72" Narrow Vender, Pepsi	142502
11	Top Trim Wide Vender	012553
	Top Trim Narrow Vender	040807
12	Bottom Trim Wide Vender	012553
	Top/Bottom Trim (M4) Narrow Vender	040811
13	Right Side Trim 79" Wide Vender	012554
	Right Side Trim 72" Wide Vender	013507
	Right Side Trim 72" Narrow Vender	019508
14	Left Vandal Panel, 79" (Specify color)	141002
	Left Vandal Panel, 72" (Specify color)	142001
15	Pop Rivet	908018
•	Christmas Tree	916009

NOTE #1: There are various parts. Please specify model and serial number at the time of order

SECTION 6: EXPLODED VIEWS AND PART NUMBERS

Door Assembly, Rear

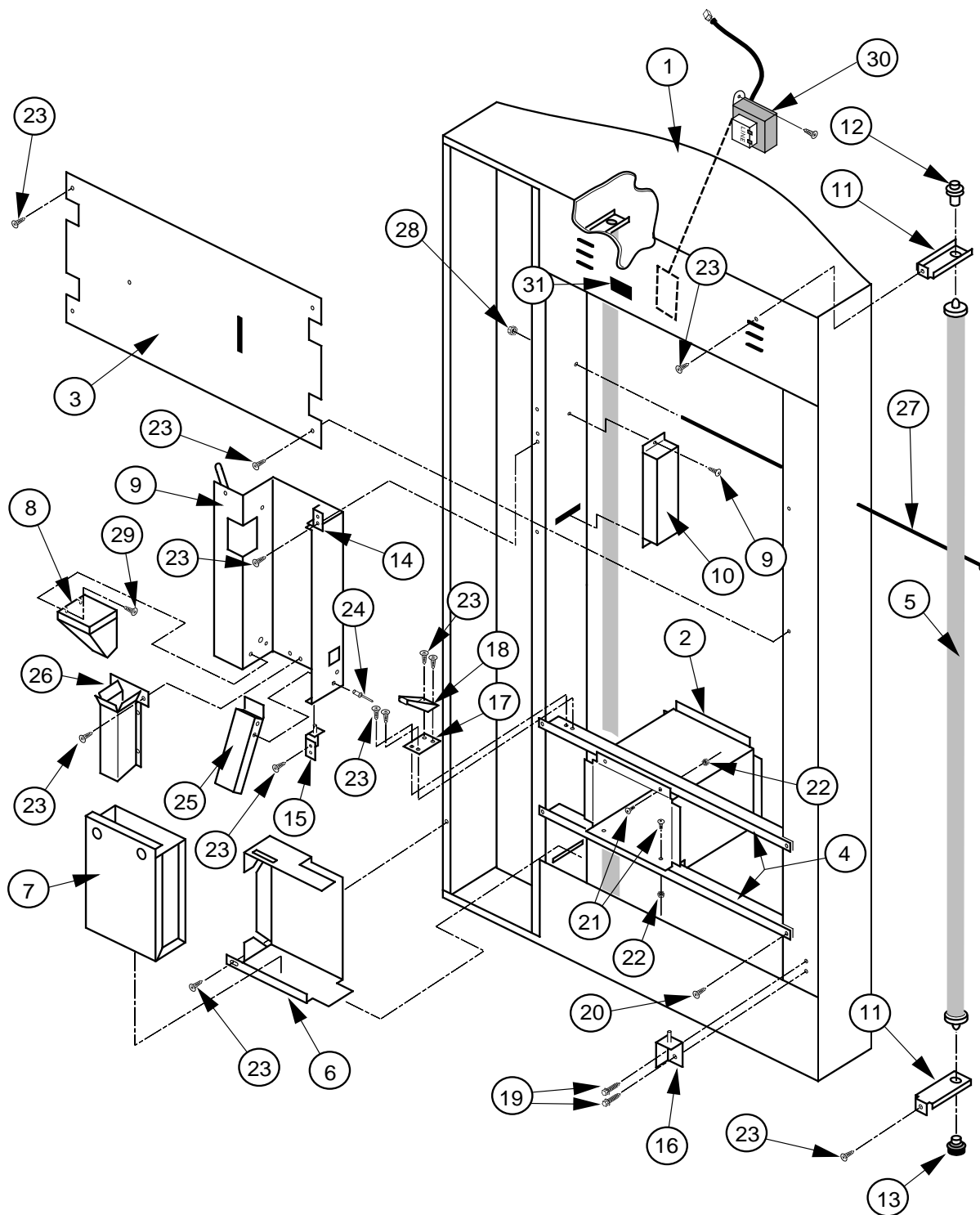

I.D.# A235,049,003RV

SECTION 6: EXPLODED VIEWS AND PART NUMBERS

Door Assembly, Rear

ITEM #	DESCRIPTION	PART NUMBER
1	Door Weld Assembly, 10 Sel. 79" Wide Vender	227570
	Door Weld Assembly, 8 Sel. 79" Narrow Vender	263580
	Cold Drink Door Weld Assembly, 10 Sel. 79" W.V (1533 & before).	216510
	Cold Drink Door Weld Assembly, 8 Sel. 79" N.V (1533 & before).	268510
2	Port Body Welded Assembly (Narrow Port)	210510
	Port Body Welded Assembly (Wide Port)	273560
3	Lamp Guard, Wide Venders	012514
	Lamp Guard, Narrow Vender, Merlin IV	258505
4	Port Brace, Wide Venders	010515
	Port Brace, Narrow Vender, Merlin IV	258506
5	Lamp, Slimline For 79" Vender	841005
	Lamp, Slimline For 72" Vender	841006
6	Coin Box Housing (1405 & after)	273540
7	Coin Box Welded Assembly (1405 & after)	815347
8	Coin Hopper	815015
9	Changer Door	010544
10	Ballast Assembly, 79" Wide Vender, Non CDC	012940
	-72", Non CDC	013920
	-79", CDC	198920
	-72", CDC	195910
11	Lamp Bracket	010517
12	Top Lampholder	842003
13	Bottom Lampholder	842004
14	Changer Door Hinge Assembly, Top	010570
15	Changer Door Hinge Assembly, Bottom	010560
16	Bottom Inner Door Hinge	010550
17	Latch Roller Bracket	010516
18	Burst Open Latch Strike	812003
19	Self Tapping Screw, 1/4-20x1"	901003
20	Self Drilling Screw, #8-32	902004
21	Carriage Bolt, 1/4-20x1/2"	901007
22	Keps Nut, 1/4-20	905002
23	Sems Screw, #8-32x3/8"	901011
24	Pop Rivet, 1/8"	908004
25	Bottom Coin Chute Assembly (To Coin Box)	012593
26	Hopper Chute Assembly (To Coin Cup)	012538
27	Door Rod	811001
28	Elastic Stop Nut	905004
29	Screw #8-32x1/2" with washers	901006
30	Transformer Assembly	010572
31	Fusebox Assembly	842219

SECTION 6: EXPLODED VIEWS AND PART NUMBERS

Select Panel Assembly, Rear

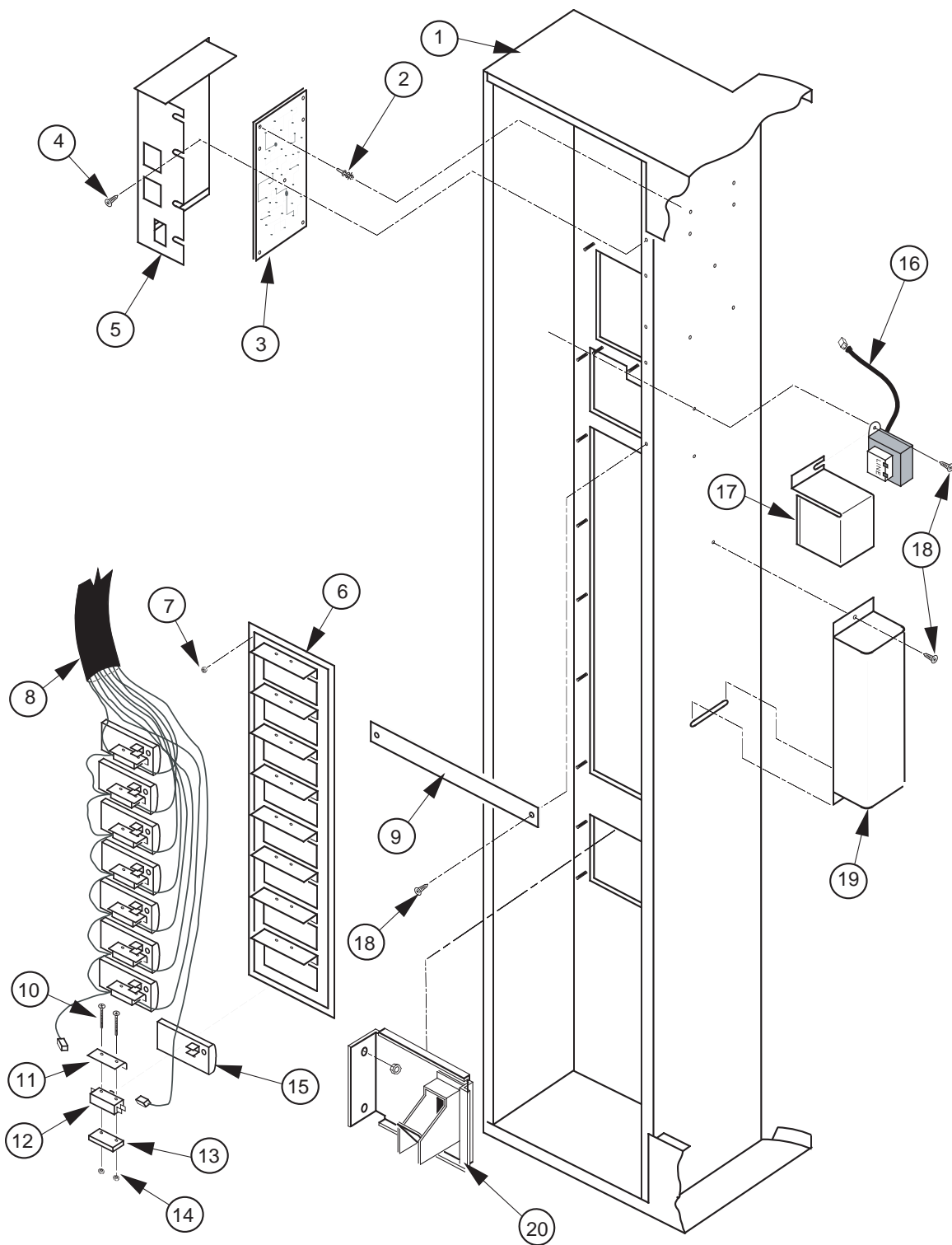

I.D.# A235,051,003RV

SECTION 6: EXPLODED VIEWS AND PART NUMBERS

Select Panel Assembly, Rear

ITEM #	DESCRIPTION	PART NUMBER
1	Door Weld Assembly, 10 Sel. 79" Wide Vender	227570
	Door Weld Assembly, 8 Sel. 79" Narrow Vender	263580
	Cold Drink Door Weld Assembly, 10 Sel. 79" WV (1533 & before)	216510
	Cold Drink Door Weld Assembly, 8 Sel. 79" NV (1533 & before)	268510
2	PC Board Spacer	916027
3	Control Board	836101
4	Self Drilling Screw, #8-18x1/2"	902004
5	Control Board Cover	141903
6	Control Panel Welded Assembly, 10 Select	017530
	Control Panel Welded Assembly, 8 Select	012510
7	Keps Nut, #8-32	905001
8	Select Switch Harness	See Note #1
9	Panel Strap (optional)	010531
10	Screw	901041
11	Spring Shield	815164
12	Switch (large)	835012
13	Switch Spacer	815018
14	Keps Nut	905018
15	Button Assembly	815025
16	Transformer Assembly)	010572
17	Transformer Cover	010063
18	Self Tapping Screw, #8-32x3/8"	901002
19	Ballast, Slimline	838002
20	Coin Return Cup (Steel)	012595
•	Splash Guard (protect sel. switches)	815303

NOTE #1: There are various parts. Please specify model and serial number at the time of order.

SECTION 6: EXPLODED VIEWS AND PART NUMBERS

RVMC/RVCD Vandal Resistant Door (CDC) Front

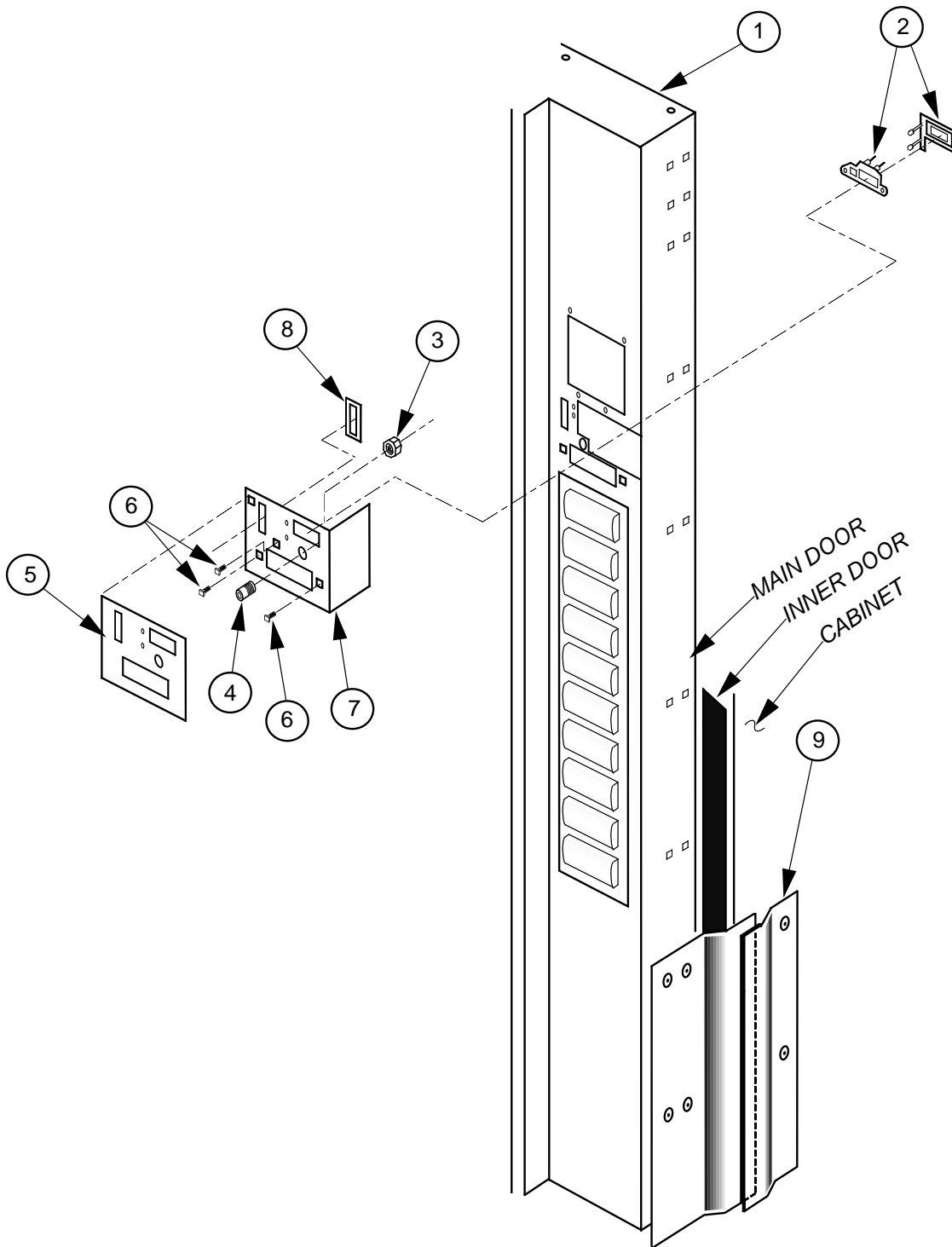

I.D.#A235,034,003RV

SECTION 6: EXPLODED VIEWS AND PART NUMBERS

RVMC/RVCD Vandal Resistant Door (CDC) Front

ITEM #	DESCRIPTION	PART NUMBER
1	C.D.C. Door Weld Assembly 79" Wide*	198522
	C.D.C. Door Weld Assembly 72" Wide*	195536
	-79" Wide Cold Drink* (1533 & before)	229510
	-72" Wide Cold Drink* (1533 & before)	230510
2	L.E.D. Assembly	010593
3	Hex Jam Nut 9/16-18	905019
4	Bushing (for coin return button)	803030
5	Security Plate Decal (Electronic, CDC)	845530
6	"T" Screw 1/4-20x1"	901037
7	Security Plate Weld Assembly (CDC Only)	195510
8	Coin Plate	141516
9	Vandal Panel Cover 79"	171101
	Vandal Panel Cover 72"	172001

* Denotes that a color must be specified

SECTION 6: EXPLODED VIEWS AND PART NUMBERS

RVMC/RVCD Vandal Resistant Door (CDC) Rear

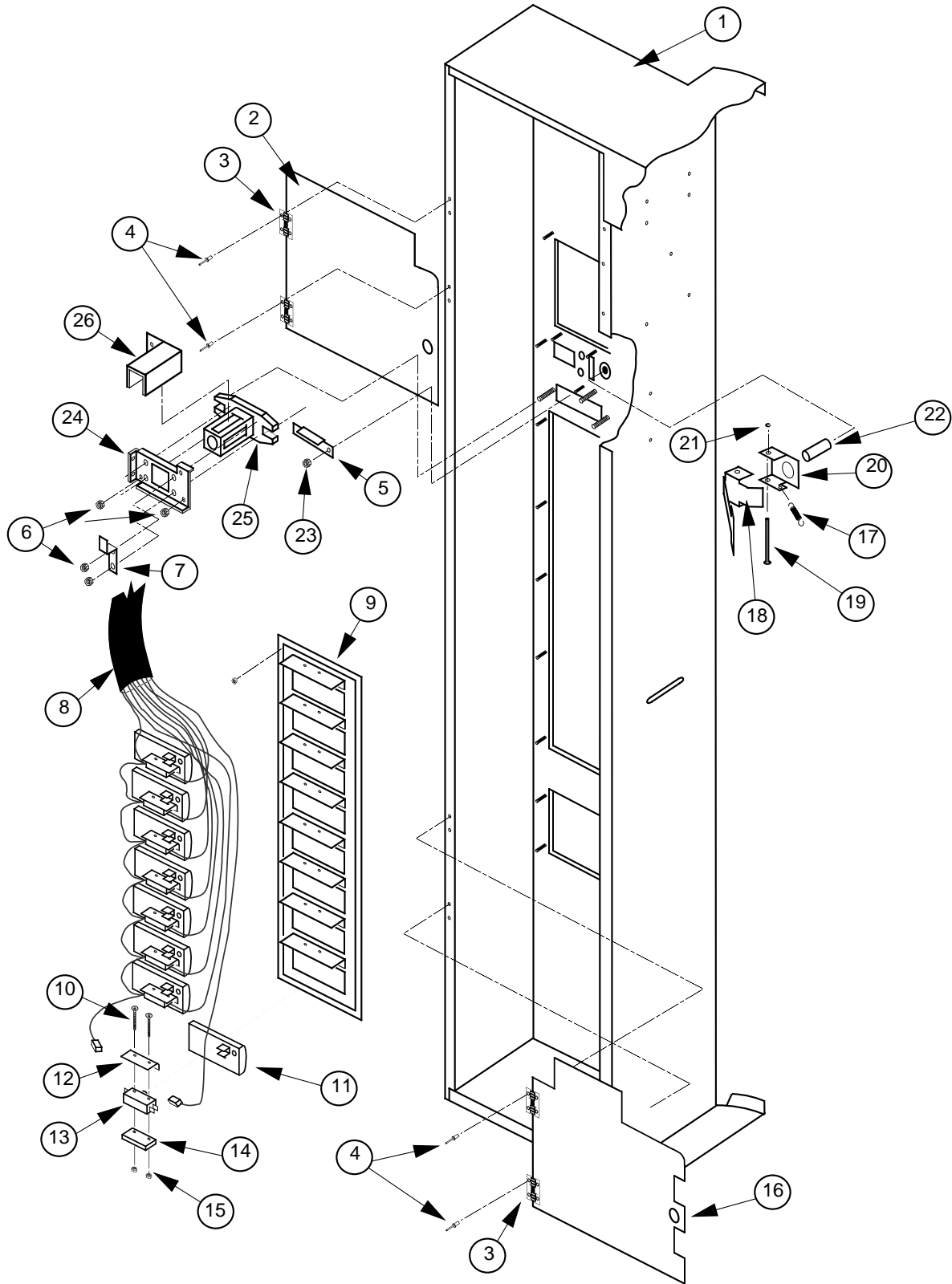

I.D.#A235,036,003RV

SECTION 6: EXPLODED VIEWS AND PART NUMBERS

RVMC/RVCD Vandal Resistant Door (CDC) Rear

ITEM #	DESCRIPTION	PART NUMBER
1	CDC Door Weld Assembly 79" Wide	198522
	CDC Door Weld Assembly 72" Wide	195536
	-79" Wide ,Cold Drink (1533 & before)	229510
	-72" Wide ,Cold Drink (1533 & before)	230510
2	Validator Security Door	141521
3	Spring Hinge (for Security Doors)	912156
4	Pop Rivet 1/8"	908004
5	Coin Ramp	141508
6	Nut 1/4-20	905002
7	Lever Stop	141514
8	Select Panel Harness	SEE NOTE #1
9	Button Panel Weld Assembly-10 select	017530
	Button Panel Weld Assembly-7 select	034520
10	Screw	901041
11	Button Assembly	815025
12	Spring Shield	815164
13	Switch, Large	835012
14	Switch Spacer	815018
15	Nut	905018
16	Cash Box Guard (Security Door)	011147
17	Coin Return Spring	914023
18	Button Lever (Coin Return Lever)	161509
19	Roller Pin (5/32")	811002
20	Hinge, Button Lever	161508
21	Retaining Ring (for 5/32" Diameter Rod)	906005
22	Button, Coin Return Lever	803031
23	Nut #8-32	905001
24	T-Handle Brace	141513
25	T-Handle Housing	812190
26	Lock Cylinder Cover	161532

* Denotes a color must be specified

NOTE #1: There are various parts. Please specify model and serial number at the time of order.

SECTION 6: EXPLODED VIEWS AND PART NUMBERS

RVMC/RVCD Center Door Changer Vault

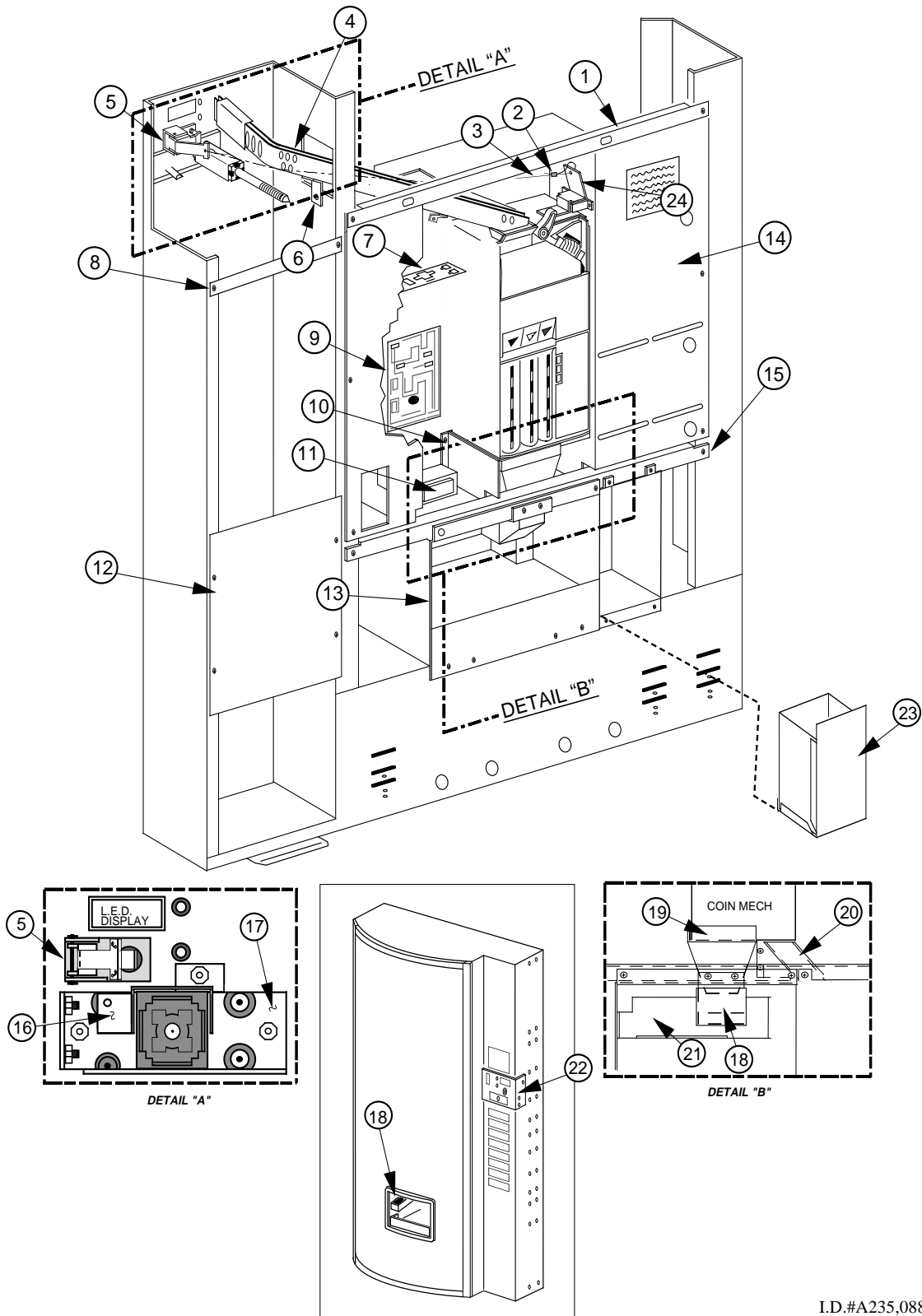

I.D.#A235,088,003RV

SECTION 6: EXPLODED VIEWS AND PART NUMBERS

RVMC/RVCD Center Door Changer Vault

ITEM #	DESCRIPTION	PART NUMBER
1	Changer Vault Brace	161518
2	Cable Sleeve (At Each End Of Cable)	906015
3	Cable	911032
4	Coin Chute Assembly / CDC Wide Vender / 79.5"	161590
5	Button Lever Assembly (see detail "A")	161594
6	Coin Chute Bracket 79.5"	161527
	Coin Chute Bracket 72"	162502
7	Changer Plug Bracket	010561
8	Panel Strap	010531
9	Control Board	836101
10	Hopper Mounting Bracket	161515
11	Transformer Assembly, MIV	842147
	Merlin IV Harness, Transformer and Fuse to Board	842210
	Fuse, 3.0	942111
12	Select Panel Plate	161512
13	Port Body Welded Assembly	273510
14	Changer Vault Welded Assembly	161523
15	Port Brace Welded Assembly	161541
16	Lock Cylinder Cover (see detail "A")	161532
17	T-Handle Brace (see detail "A")	141513
18	Coin Cup, CDC	231505
19	Coin Hopper	815015
20	Coin Box Coin Chute/Back	231507
	Coin Box Coin Chute	231506
21	Anti-Theft Plate	161504
	Anti-Theft Plate, CDC, Wide	273507
	Anti-Theft Plate, Non-CDC, Wide	263505
22	Security Plate Welded Assembly	195510
23	Coin Box Welded Assembly	161570
	-Plastic Coin Box	815347
24	Button Lever Assembly (Coin Return Lever)	161593
•	Coin Insert Assembly	195560
•	Changer Vault Door (Not Shown), Optional	161534
•	Board Cover (CDC)	195518
•	Coin Deflector	161526

SECTION 6: EXPLODED VIEWS AND PART NUMBERS

Port Assembly, Dr Pepper Vision 4

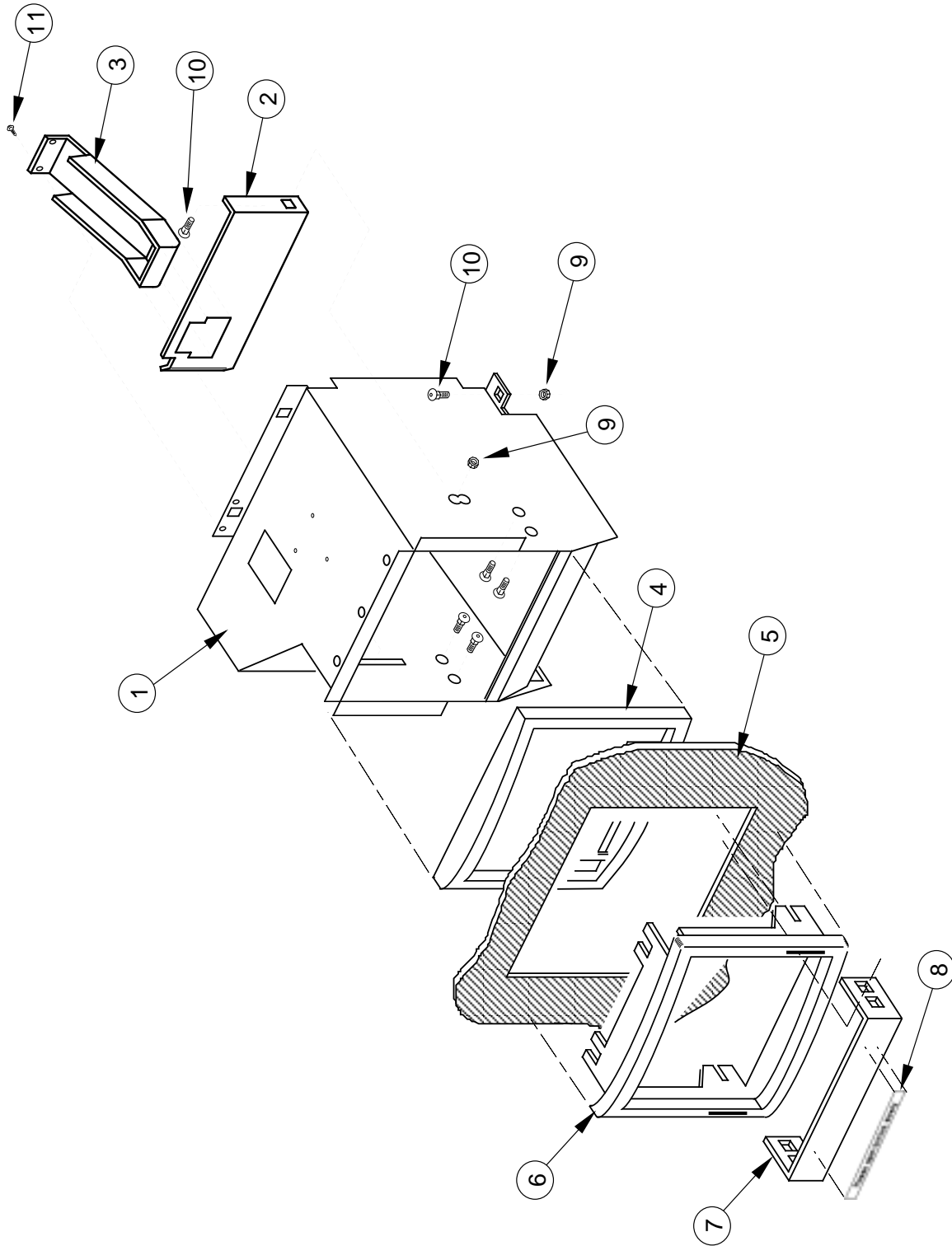

I.D.#A235,063,003RV

SECTION 6: EXPLODED VIEWS AND PART NUMBERS

Port Assembly, Dr Pepper Vision 4

ITEM #	DESCRIPTION	PART NUMBER
1	Port Body Welded Assembly / CDC	231510
2	Anti-Theft Plate / CDC	231504
3	Coin Cup / CDC	231505
4	Port Spacer	815020
5	Sign	SEE NOTE #1
6	Port Trim	815019
7	Can Stop	010508
8	Anti-Foaming Label	931355
9	Nut 1/4-20	905002
10	Carriage Bolt 1/4-20x1/2"	901007
11	Screw #8-32x3/8"	901011

NOTE #1: There are various parts. Please specify model and serial number at the time of order.

SECTION 6: EXPLODED VIEWS AND PART NUMBERS

Door Assembly Front, Dr Pepper Vision 4

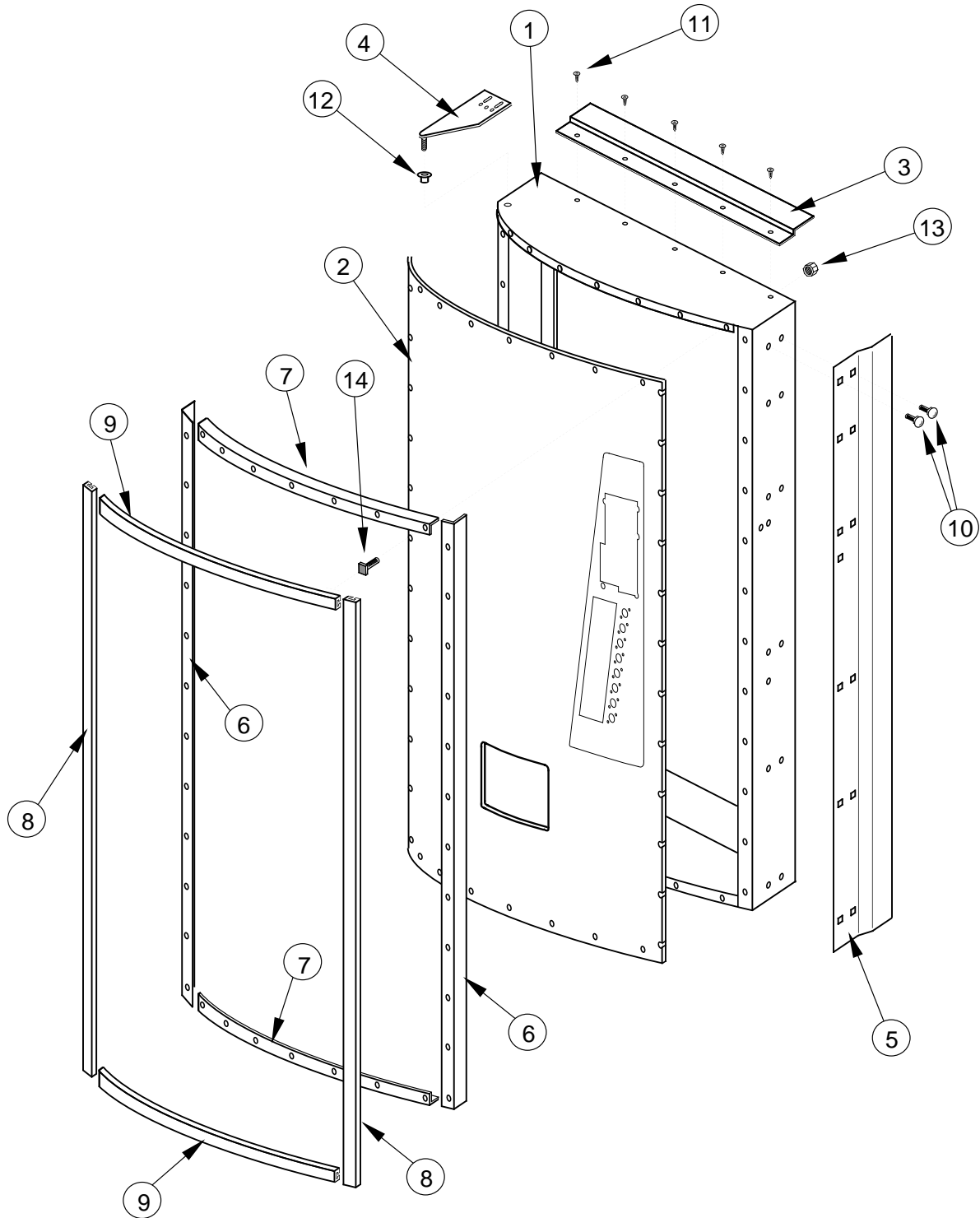

I.D.#A235,064,003RV

SECTION 6: EXPLODED VIEWS AND PART NUMBERS

Door Assembly Front, Dr Pepper Vision 4

ITEM #	DESCRIPTION	PART NUMBER
1	Main Door Welded Assembly / Vision 4 / CDC 79"	242537
	Main Door Welded Assembly / Vision 4 / CD. 72"	243550
2	Sign, Dr Pepper Vision 4 (Must Give # of Selections)	SEE NOTE #1
3	Rain Guard, Wide Venders	010518
4	Top Main Door Hinge	810002
5	Vandal Panel, Right (Door) 79"	010519
	Vandal Panel, Right (Door) 72"	011501
6	Metal Trim, Right & Left 79"	171507
7	Metal Trim, Top and Bottom	171502
8	Trim, Right and Left 79"	242526
9	Trim, Top and Bottom	242525
10	Carriage Bolt 1/4-20x1/2"	901007
11	Self Drilling Screw #8x1/2"	902004
12	Top Door Bushing	803003
13	Nut 1/4-20	905002
14	T-Bolt 1/4-20x1"	901037

NOTE #1: There are various parts. Please specify model and serial number at the time of order.

SECTION 6: EXPLODED VIEWS AND PART NUMBERS

Door Assembly Rear, Dr Pepper Vision 4

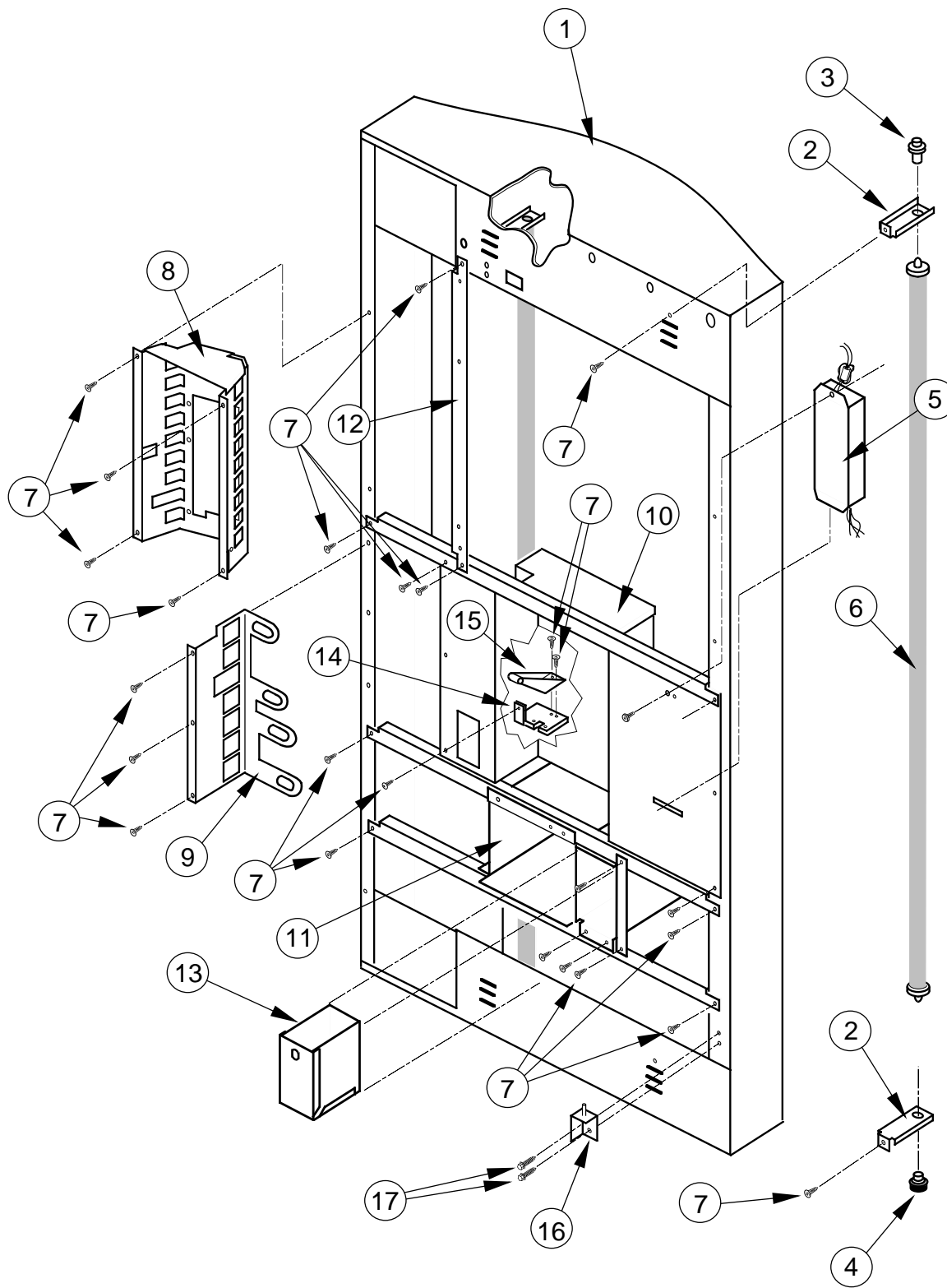

I.D.#A235,065,003RV

SECTION 6: EXPLODED VIEWS AND PART NUMBERS

Door Assembly Rear, Dr Pepper Vision 4

ITEM #	DESCRIPTION	PART NUMBER
1	Main Door Welded Assembly / Vision 4 / CDC 79"	242537
	Main Door Welded Assembly / Vision 4 / CDC 72"	243550
2	Lamp Bracket	010517
3	Top Lampholder (Springloaded)	842003
4	Bottom Lampholder	842004
5	Ballast Assembly	231560
6	Lamp, H.O. 79" Vender	841001
	Lamp, H.O. 72" Vender	841002
7	Screw #8-32x3/8"	901011
8	Validator Vault Welded Assembly	242530
9	Button Bracket Welded Assembly - DP Vision 4	242550
10	Changer Vault Welded Assembly	161523
11	Port Body Welded Assembly / CDC	231510
12	Validator Vault Brace 79"	242511
	Validator Vault Brace 72"	243501
13	Coin Box Welded Assembly, Vision 4 CDC	231550
14	Latch Roller Bracket	242512
15	Burst Open Latch Strike	812003
16	Bottom Inner Door Hinge	010550
17	Self Tapping Screw 1/4-20x1"	901003

SECTION 6: EXPLODED VIEWS AND PART NUMBERS

Coin Insert Assembly Front, Dr Pepper Vision 4

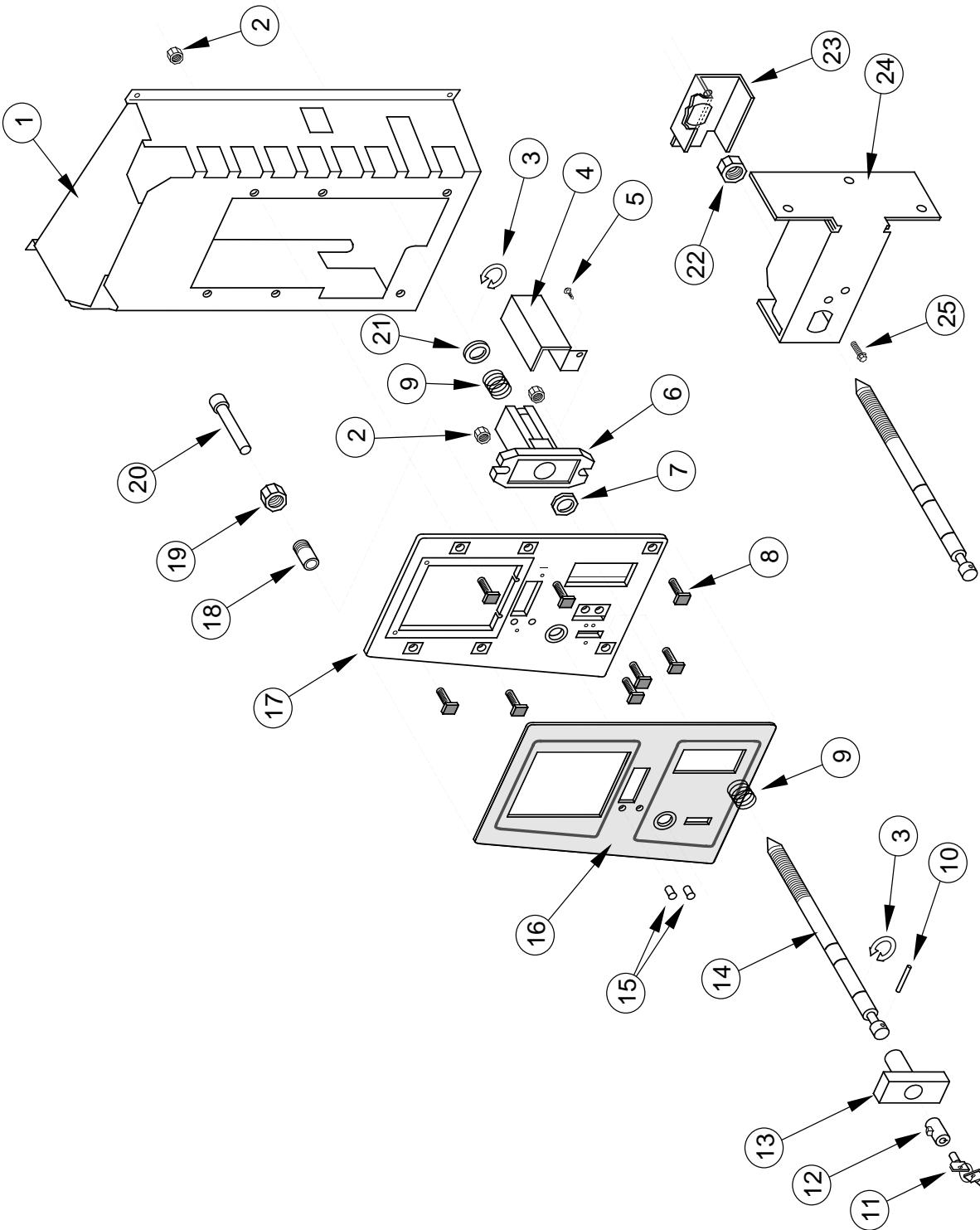

I.D.#A235,066,003RV

SECTION 6: EXPLODED VIEWS AND PART NUMBERS

Coin Insert Assembly Front, Dr Pepper Vision 4

ITEM #	DESCRIPTION	PART NUMBER
1	Validator Vault Welded Assembly	242530
2	Nut 1/4-20	905002
3	Retaining Ring ("C" Clip)	912157
4	Lock Cylinder Cover	161532
5	Self Tapping Screw #8-32x3/8"	901011
6	T-Handle Housing	812190
7	Brass Hex Washer	SEE NOTE #2
8	T-Bolt 1/4-20x1"	901037
9	Spring, T-Handle	SEE NOTE #2
10	Pin, T-Handle	912133
11	2 Keys	SEE NOTE #1
12	Lock	SEE NOTE #1
13	T-Handle Body	812134
14	T-Handle Stud	SEE NOTE #2
15	LED Lens	916032
16	Security Plate Decal / Dr Pepper Vision 4	845765
17	Security Plate Welded Assembly	242520
18	Bushing, Button Coin Return	803030
19	Hex Jam Nut 9/16-18 UNF2A	905019
20	Button, Coin Return Lever	803031
21	Washer	SEE NOTE #2
22	Square Nut 3/4x1/2-13	905005
23	Nut Retainer	010028
24	Latch Strike	242030
25	Self Tapping Screw 1/4-20x1"	901003
•	Latch Strike Assembly	242031
•	T-Handle Assembly, Vision 4	812277

NOTE #1: There are various parts. Please specify model and serial number at the time of order.

NOTE #2: This part is not available individually. It must be ordered as an assembly.

SECTION 6: EXPLODED VIEWS AND PART NUMBERS

CI Rear & Button Panel Assembly, Dr Pepper Vision 4

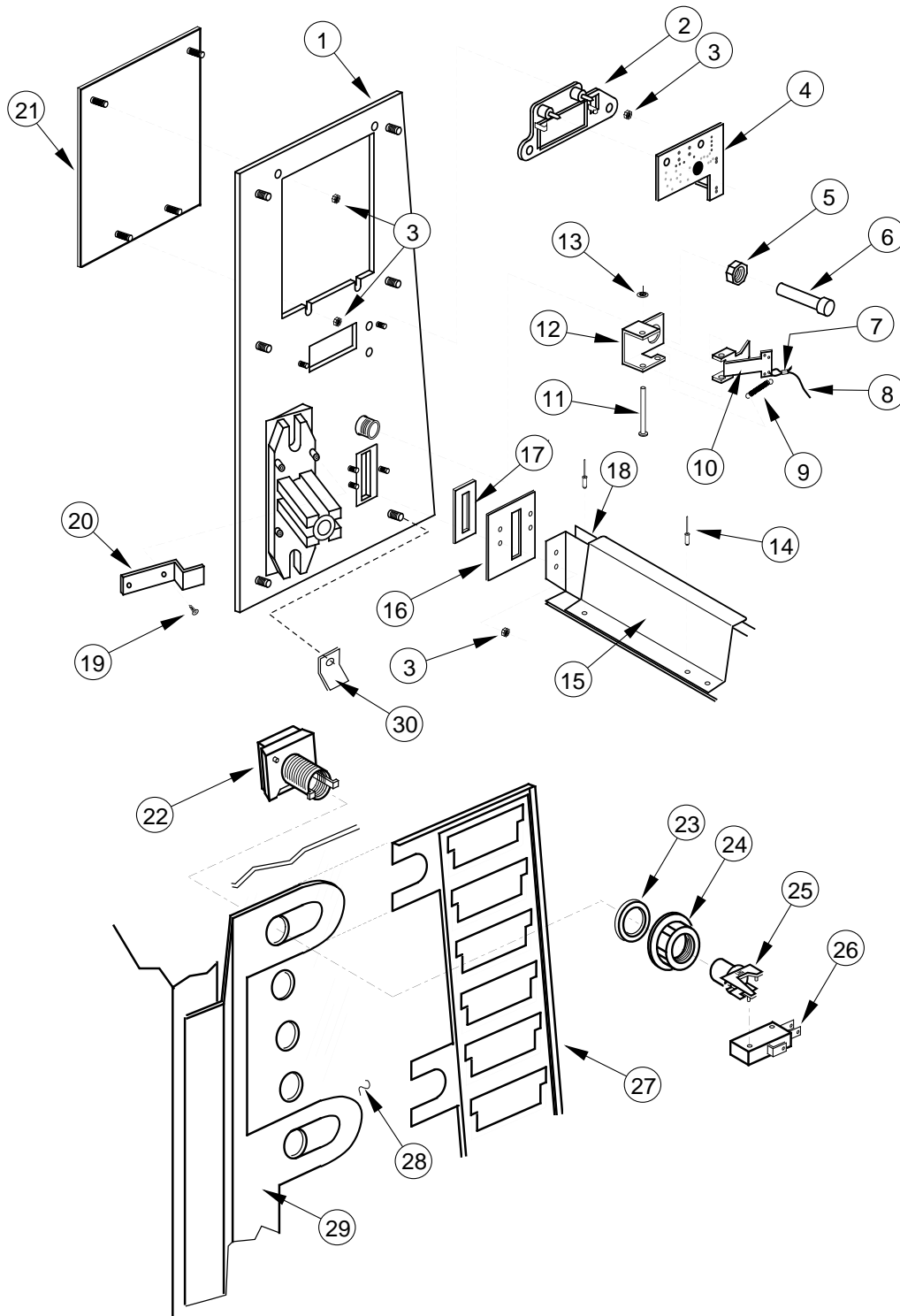

I.D.#A235,067,003RV

SECTION 6: EXPLODED VIEWS AND PART NUMBERS

CI Rear & Button Panel Assembly, Dr Pepper Vision 4

ITEM #	DESCRIPTION	PART NUMBER
1	Security Plate Welded Assembly	242520
2	LED Window	815121
3	Nut #8-32	905001
4	LED Display	836012
5	Hex Jam Nut 9/16-18 UNF2A	905019
6	Button, Coin Return Lever	803031
7	Cable Sleeve	906015
8	3/64" Diameter Cable	911032
9	Coin Return Spring	914023
10	Button Lever	161509
11	Coin Return Pin	811024
12	Hinge	161508
13	5/32 Retainer Ring	906005
14	Pop Rivet 1/8 Aluminum	908004
15	Coin Chute Cover - DP	242517
16	Coin Slot Retainer	242513
17	Coin Plate	141516
18	Coin Chute Assembly (includes #15 & #14)	242570
19	Self Tapping Screw #8-32x3/8"	901011
20	Lever Stop - DP	242521
21	Validator Cover Assembly - DP	100504
22	Button Assembly - DP	810052
23	Washer, Select Button - DP (Part of Button Assembly)	915230
24	Nut, Select Button - DP (Part of Button Assembly)	915229
25	Switch Holder - DP (Part of Button Assembly)	915225
26	Switch, Miniature	835001
27	Flavor Card Strip Assembly - DP Vision 4	815228
28	Sign, Dr Pepper Vision 4 (must give # of selections)	SEE NOTE #1
29	Button Bracket Welded Assembly	242550
30	Flavor Card Strap, DP	242536
•	Select Button Assembly, Complete (includes #22-#25)	242580
•	Button Lever Assembly (Includes #9-#13)	161594

NOTE #1: There are various parts. Please specify model and serial number at the time of order.

SECTION 6: EXPLODED VIEWS AND PART NUMBERS

Changer Vault Assembly, Dr Pepper Vision 4

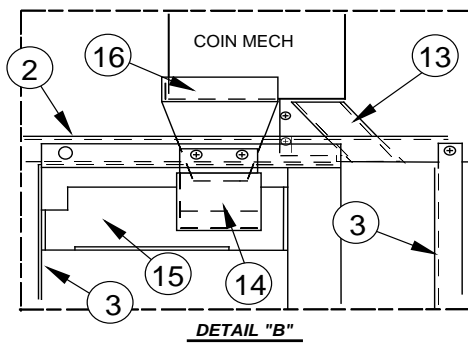
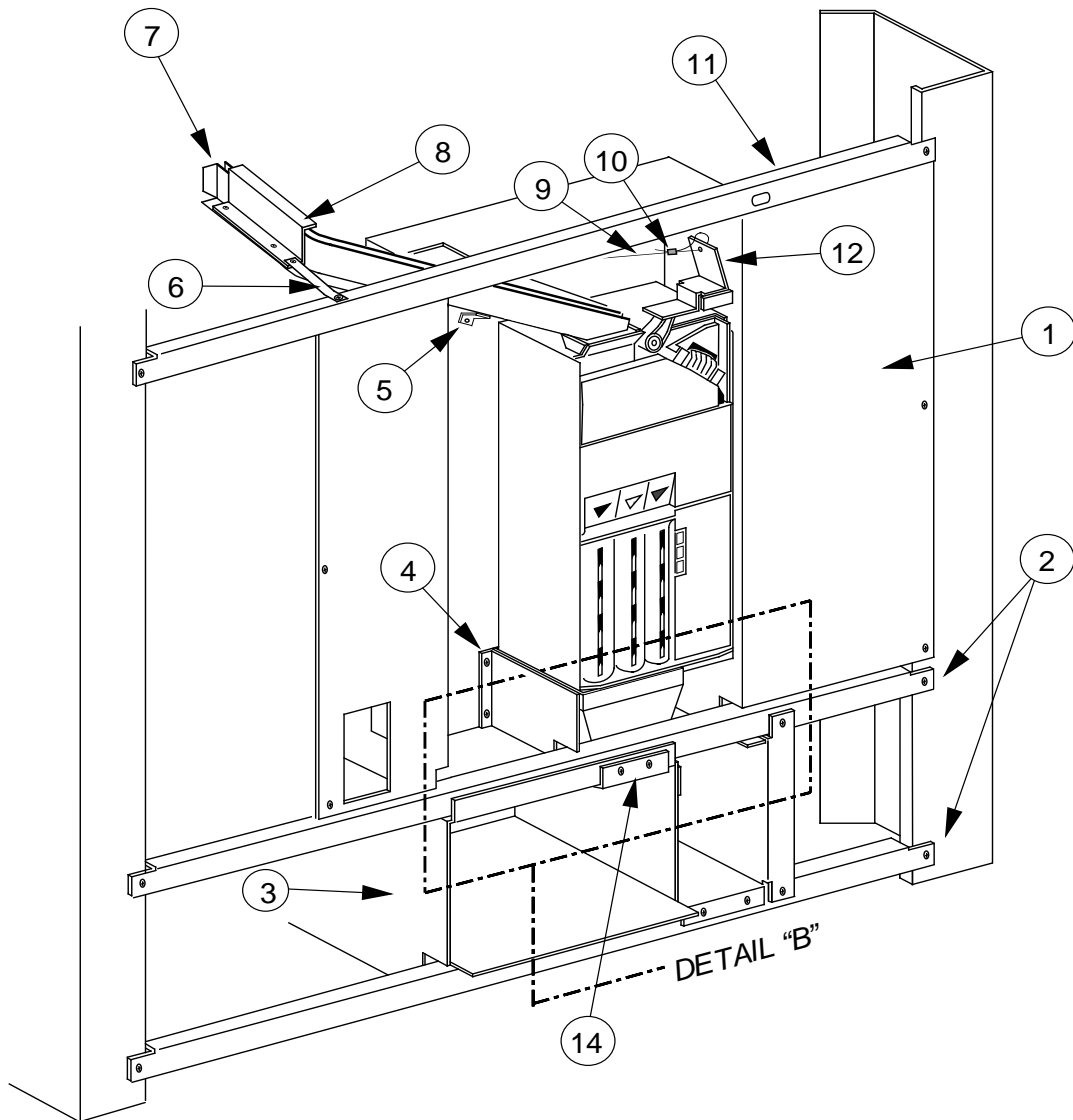

I.D.#A235,068,003RV

SECTION 6: EXPLODED VIEWS AND PART NUMBERS

Changer Vault Assembly, Dr Pepper Vision 4

ITEM #	DESCRIPTION	PART NUMBER
1	Changer Vault Welded Assembly	161523
2	Port Brace, DP / CDC	242503
3	Port Body Welded Assembly / CDC	231510
4	Hopper Mounting Bracket	161515
5	Support Bracket, Coin Chute / CDC	161537
6	Coin Chute Strap - DP	242516
7	Coin Chute Assembly (includes #5, #6 and #8).....	242570
8	Coin Chute Cover - DP	242517
9	3/64" Diameter Cable	911032
10	Cable Sleeve	906015
11	Changer Vault Brace	242504
12	Coin Return Lever Assembly	161593
13	Coin Box Coin Chute Welded Assembly	231519
14	Coin Cup - CDC	231505
15	Anti Theft Plate - CDC	231504
16	Coin Hopper	815015
•	Coin Chute Bracket, 79" CDC (Not Shown)	161527
•	Water Block, Coin Chute / DP - CDC (Not Shown)	161536

SECTION 6: EXPLODED VIEWS AND PART NUMBERS

Flat Horizontal Display, Door Front

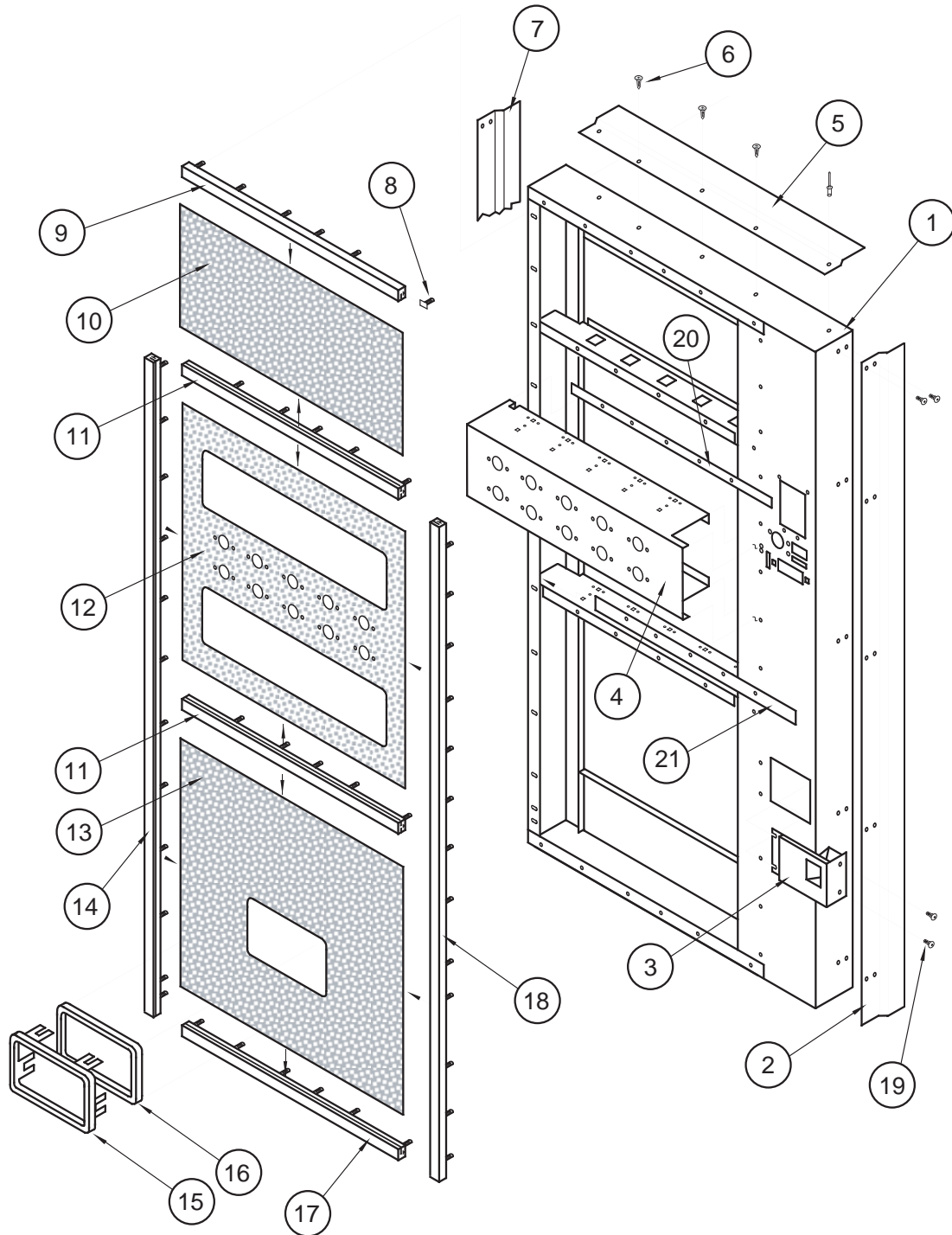

I.D.#A235,072,003RV

SECTION 6: EXPLODED VIEWS AND PART NUMBERS

Flat Horizontal Display, Door Front

ITEM #	DESCRIPTION	PART NUMBER
1	Door Welded Assembly - Flat Display - 72"	278552
2	Right Vandal Panel - 72"	011501
3	Coin Return Cup Welded Assembly	012595
4	Button Panel - Flat Display - 10 Select	278502
5	Rain Guard - Wide Venders	010518
6	Screw #8 x 1/2"	902004
7	Left Vandal Panel, 79"	141002
	Left Vandal Panel, 72"	142001
8	T-Screw #8-32	901001
9	Trim, Top Side	032807
10	Sign, Top / Flat Display (Cold Drink Graphics)	845918
11	Trim, Center	278511
12	Sign, Center / Flat Display	845919
13	Sign, Bottom / Flat Display	845920
14	Trim, Left Side	019507
15	Port Trim, Wide Port	815249
16	Port Spacer, Wide Port	815248
17	Trim, Bottom Side	032806
18	Trim, Right Side	019508
19	Carriage Bolt 1/4-20 x 1/2"	901007
20	Price Label Strip - Top	278512
21	Price Label Strip - Bottom	278515

SECTION 6: EXPLODED VIEWS AND PART NUMBERS

Flat Horizontal Display, Door Rear

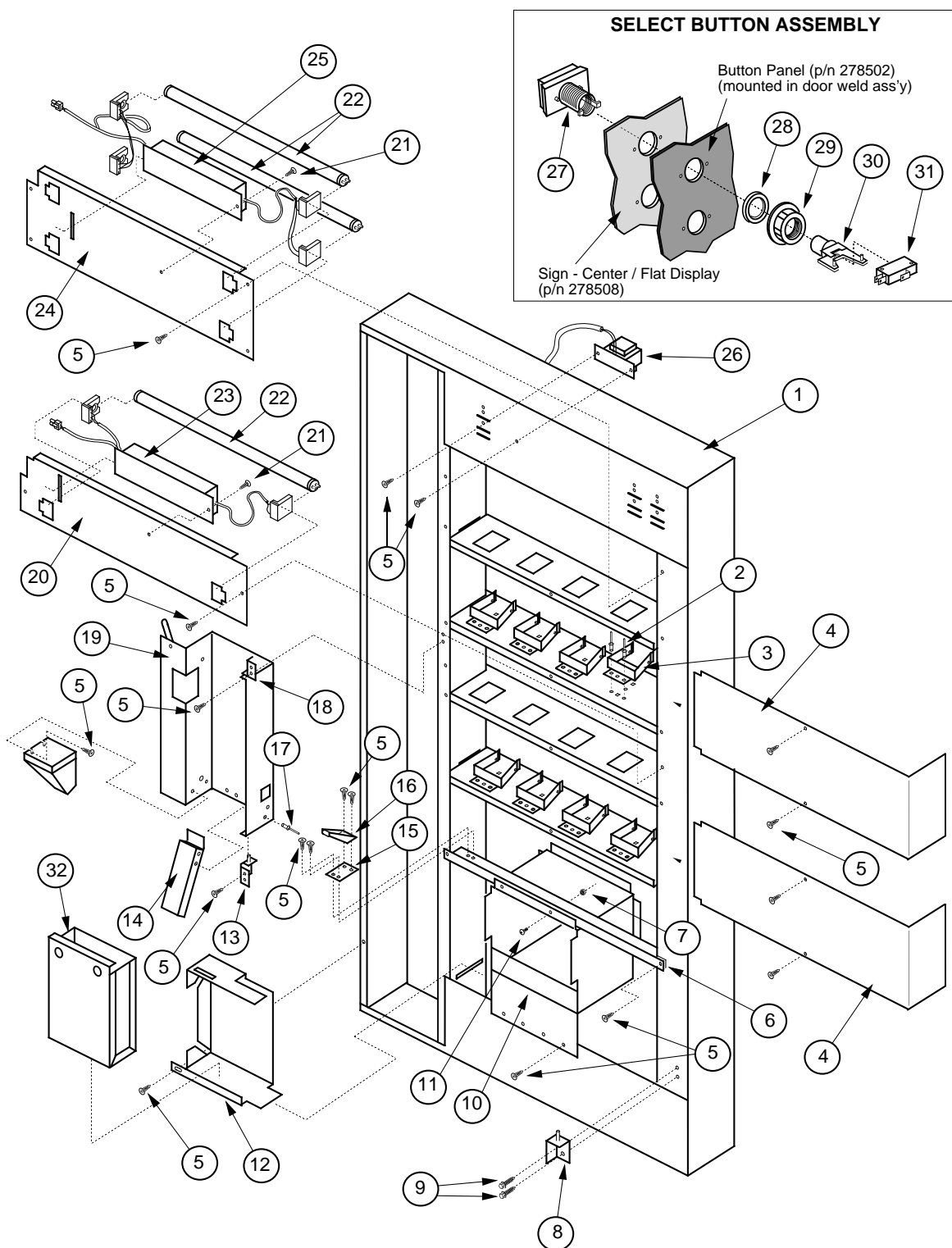

I.D.#A235,073,003RV

SECTION 6: EXPLODED VIEWS AND PART NUMBERS

Flat Horizontal Display, Door Rear

ITEM #	DESCRIPTION	PART NUMBER
1	Door Welded Assembly - Flat Display - 72"	278552
2	Pop Rivet 1/8" diameter	908004
3	Display Product Holder	023107
4	Display Back - Flat Display	278505
5	Screw #8 x 1/2"	902004
6	Port Brace, Wide Vender	010515
7	Nut 1/4-20	905002
8	Inner Door Hinge, Bottom	010550
9	Self Tapping Screw 1/4-20 x 1"	901003
10	Port Body Welded Assembly - Flat Display	278520
11	Carriage Bolt 1/4-20 x 1/2"	901007
12	Coin Box Housing	010537
13	Bottom Changer Door Hinge W/A	010560
14	Bottom Coin Chute Assembly (to Coin Box)	012593
15	Latch Roller Bracket	010516
16	Burst Open Latch Strike	812003
17	Pop Rivet 1/8" dia. Stainless Steel	908001
18	Top Changer Door Hinge W/A	010570
19	Changer Door	010544
20	Lamp Panel - Bottom (Single Bulb)	278507
21	Screw #8-32 x 1/2" w Flat Washer	901006
22	Lamp 20 watt 24" long	841012
23	Ballast - Single Bulb	838005
	Ballast Assembly - Flat Display (Single Bulb)	122518
24	Lamp Panel - Top (Double Bulb)	278506
25	Ballast - Double Bulb	838024
	Ballast Assembly - Flat Display (Double Bulb)	122528
26	Transformer Assembly	010572
27	Button Assembly	not available
28	Washer, Select Button	not available
29	Nut, Select Button	not available
30	Switch Holder	not available
*	Complete Button Assembly (items 27, 28, 29, 30)	816016
31	Switch, Miniature	835001
32	Coin Box W/A	010580

SECTION 6: EXPLODED VIEWS AND PART NUMBERS

Flat Horizontal Display, Select Panel

ITEM #	DESCRIPTION	PART NUMBER
1	Door Welded Assembly - Flat Display - 72"	278552
2	LED Display Assembly	010593
3	Coin Plate	141516
4	Security Plate Welded Assembly	216502
5	T-Screw 1/4-20 x 1"	901037
6	LED Lens (Part of LED Assembly)	916032
7	Security Plate Decal	845641
8	Bushing (for coin return button)	803030
9	Hex Jam Nut 9/16-18	905019
10	T-Handle Assembly (prior to 1521)	812176
	-1521 and after	812289
11	T-Handle Body (part of T-Handle Assembly)	not available
12	Spring, T-Handle Assembly (part of T-Handle Assembly)	not available
13	Retainer Ring, T-Handle (part of T-Handle Assembly)	not available
14	T-Handle Stud (part of T-Handle Assembly)	not available
15	Pin, T-Handle (part of T-Handle Assembly)	not available
16	Button, Coin Return	803031
17	Retaining Ring 5/32"	906005
18	Hinge, Coin Return Lever	141506
19	Pin, Coin Return Lever	811002
20	Coin Return Lever	141504
21	Screw #8-32 x 3/8"	901011
22	Spring, Coin Return Lever	914003
23	Nut #8-32	905001
24	Coin Ramp	141508
25	T-Handle Housing	812190
26	Nut 1/4-20	905002
27	Lever Stop	141514
28	T-Handle Brace	141513
29	Lock Cylinder Cover	161532
30	Screw #8-18 x 1/2"	902004
31	Control Board Cover	141903
32	Control Board	836101
33	PC Board Spacer	916027

PROGRAMMING FLOWCHART



External Menu

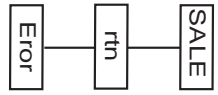

Internal (Service) Menu

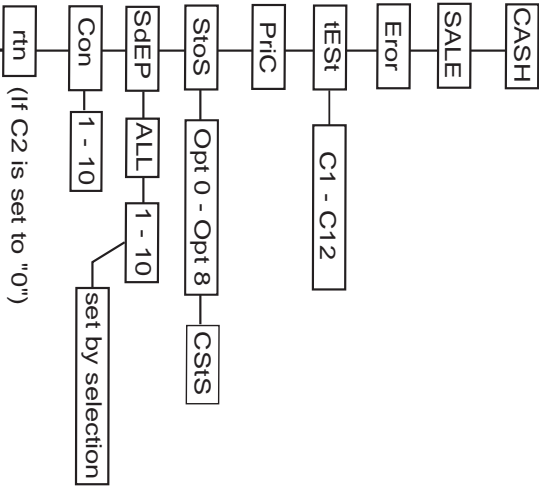

Optional Menu Items (If C2 is set to "1")

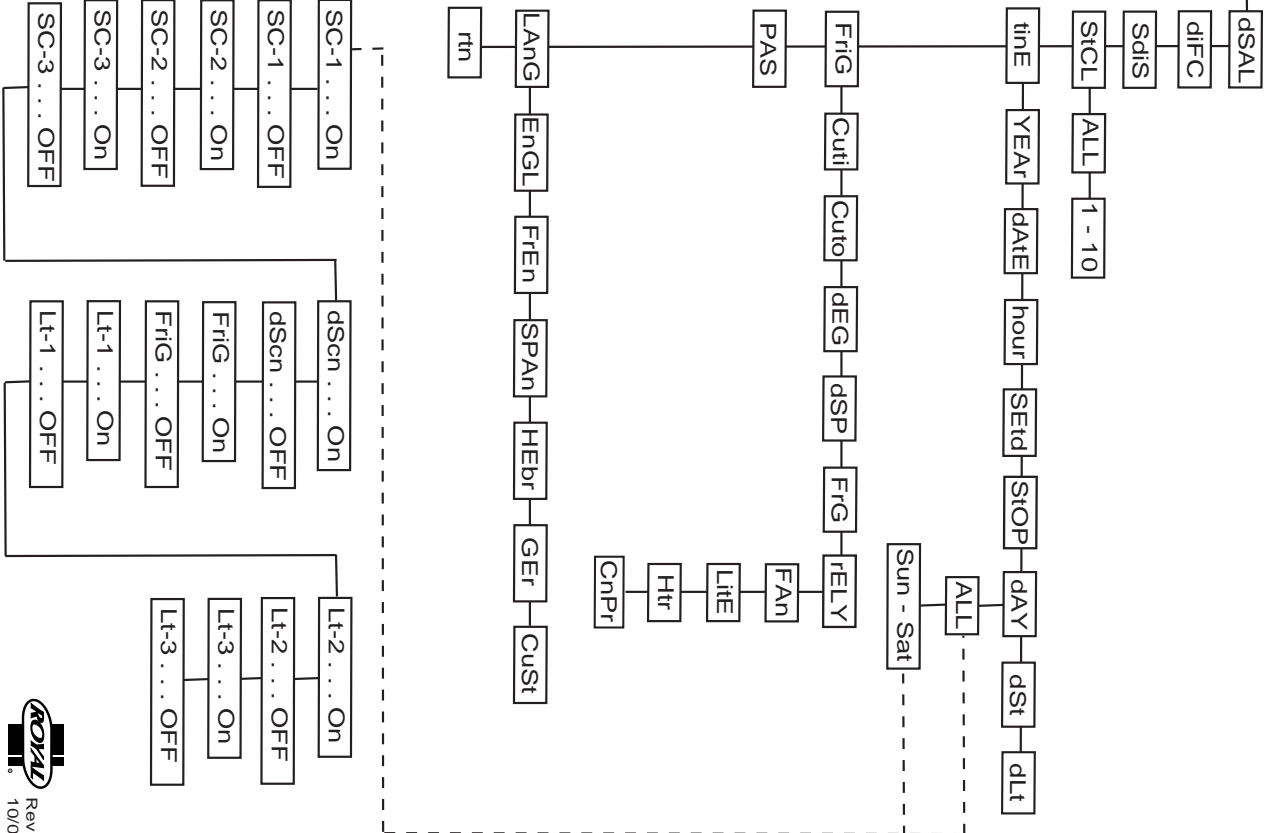
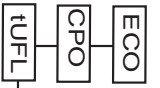



Made in the U.S.A.



Royal Vendors' Publication

833021

Rev. L 10-01